

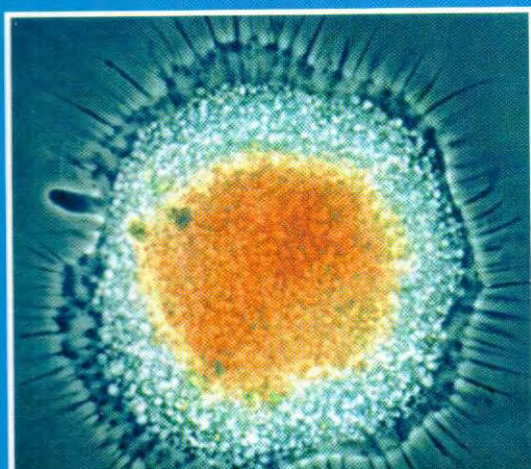

К. Кочеван,
Н. Кочеван,
П. Павлов

БОТИСТОЛОГИЯ



Tetramastigota

- Retortamonadea
- Diplomonadea
 - Enteromonadida
 - Diplomonadida
- Oxymonadea
- Parabasalea
 - Trichomonadida
 - Hypermastigida

Discicristata

- Euglenozoa
 - Euglenida
 - Kinetoplasta
 - Bodonea
 - Trypanosomatidea
 - Diplonemida
- Heterolobosa
 - Schizopyrenidea
 - Acrasea

Hemimastigophora

Pseudociliata

Chromista

- Prymnesiomonada
- Cryptomonada
- Heterokonta
 - Proteromonadea
 - Opalineae
 - Chrysomonadea
 - Chrysomonadida
 - Pedinellida
 - Silicoflagellida
 - Bacillariophyceae
 - Heteromonadea
 - Eustigmatophyceae
 - Labyrinthulea
 - Raphidomonadea
 - Bicosoecidea
 - Hyphochytriomycetes
 - Oomycetes

Alveolata

- Dinoflagellata
- Diniferea

Syndinea

- Perkinsozoa
 - Family Colpodellidae

Apicomplexa

- Gregarinea
- Coccidea
 - Agamococcida
 - Protococcida
 - Adeleida
 - Eimeriida

Haematozoa

- Haemosporida
- Piroplasmida

Ciliophora

Postciliodesmatophora

- Karyorelictea
 - Protostomatida
 - Loxodida
 - Protoheterotrichida

Heterotrichea

- Licnophorida
- Heterotrichida

Intramacronucleata

Spirotrichea

- Protocruziidia
- Phacodiniidia
- Hypotrichia
- Oligotrichia
- Choreotrichia
- Stichotrichia

Litostomatea

- Haptoria
- Trichostomatia

Phyllopharyngea

- Phyllopharyngia
- Rhynchodia
- Chonotrichia
- Suctorina

Nassophorea

- Synhymeniida
- Nassulida
- Microthoracida

Colpodea

- Prostomatea
- Plagiopylea
- Oligohymenophorea

- Peniculia
- Scuticociliatia
- Hymenostomatia
- Apostomatia
- Peritrichia
- Sessilida
- Mobilida
- Astomatia
- Clevelandellida
- Odontostomatida
- Haplospora

Cercozoa

- Phytomyxa
- Reticulofilosa
- Monadofilosa

Foraminifera

Biliphyta

- Rhodophyta
- Glaucocytophyta

Viridiplantae

- Chlorophyta
- Prasinomads
- Ulvophyceae
- Trebouxiophyceae
- Chlorophyceae
- Volvocida
- Chlorococcales
- Streptophyta
- Mesostigmatophyceae
- Chlorokybophyceae
- Klebsormidiophyceae
- Conjugatophyceae

Amoebozoa

- Lobosa
- Gymnamoebea
- Acarpomyxea
- Testacealobosea

Conosa

- Archamoeba
- Mycetozoa
- Eumyxa
- Protostelea
- Myxogastrea
- Dictyostela
- Aconchulin

Opisthokonta

Fungi

- Chytridiomycota
- Zygomycota
- Eumycota
- Microspora
- Microsporea
- Rudimicrosporia
- Microsporia
- Ascomycota
- Archaeascomycota
- Hemiascomycota
- Euascomycota
- Family Nephridiophagidae
- Basidiomycota
- Choanozoa
- Mesomycetozoa
- Choanoflagellata
- Metazoa
- Myxozoa

Eukaryota incertae sedis

Actinopoda

- Acantharea
- Polycystinea
- Phaeodarea
- Heliozoa
- Actinophryida
- Desmothoracida
- Ciliophryida
- Taxopodida
- Centrohelida

Paramyxea

593.1
28.691
X 26

Protistology, by Klaus Hausmann, Norbert Hiilsmann, Renate Radek

H., : , 2010. — 495 ,

(2003).

384 . 22

— *Trypanosoma brucei* () (Oliver Meckes

Nicole Ottawa, Reutlingen, Germany). : 1450x;

— *Vampyrella ulothrichis* (-
) (Norbert Hiilsmann, Berlin, Germany). : 450*;

— *Paramecium bursaria* ; -

DAPI). — ()
(Arthur Hauck, Pfalzgrafeweiler, Germany). : 500x.

© E. Schweizerbart'sche Verlagsbuchhandlung,
Stuttgart (Germany), 2003

© , , 2010

© , , 2010

ISBN 978 5 87317 662 5

Из предисловия авторов ко второму изданию

Protozoology -

10 -

1985 -

1995

Предисловие авторов к третьему изданию

1956 : « Protozoologie, » ;

1985 — ».

Protozoology Protistology,

« »

(Hans Machemer),

(Bochum),

Hallenberg,
(Maria Mu
Sauerland,
lisch)

(Gunter Steinbrück)

: « »

(), « »

(), « » ()

« » ().

(Frederic Bartlett),

(Karl Gottfried Grell)

« »

(Peter Adam) — ;
-
, — -
-
, Georg Thieme
Verlag Stuttgart.
(. Tosun) () - (Erhard
, Nägele) Schweizerbart'sche Verlags
, buchhandlung ,
-
(Stefanie () -
Kortfleisch) ,
-
(Marcus Schober). -
,
2003

«
1988
»
1996
(2003)
«Protisto
logy»,
2003
Hausmarm,
(sakarpov4@gmail.com,
s_korsun@ocean.ru).

I.

()

(,).

—Ur Thiere.

« »

«zoon»

Protozoa

(Ernst Haeckel, 1866).

(« »)

1818

(Georg August Goldfuss,
Protozoa.

1782 1848)

1

Protozoa (Protista)

— **Animalcula** (

— Antoni van Leeuwenhoek, 1676):

Animalia, . . .

Volvocida,

Myxogastrea.

(
Gottfried Wilhelm Leibniz, 1714):

(Myxozoa),

Metazoa.

Protista

()
 , -
 , -
 :
Monas O.F. Müller, 1786; Cryptomonada
 Ehrenberg, 1838; Chrysomonadida Engler,
 1898; Diplomonadida Wenyon, 1926; Tri
 chomonadida Kirby, 1947; Proteromona
 dida Grasse, 1952; Prasinomonadea Chris
 tensen, 1962.

— **Infusoria**, **Animalcula**
Infusoria (— Mar
 tin Frobenius Ledermüller, 1760
 1763):
 (*Aufgufittierchen*).

()
 , -
 .
 (Jean Baptiste de
 Lamark, 1744—1829)
 Infusoria

XIX
 XX ()
 , -
)

Urthiere (.) (—
 Lorenz von Oken, 1805):
 Infusoria,

« -
 » (. = Urtiere),

— **Protozoa** (-
 — Georg August GoldfuB,
 1818):
 Infusoria
 « »
 1845 , (Carl
 Theodor von Siebold)

Animalia Microscopica (—
 Jean Baptiste
 Bory de Saint Vincent, 1826):
 Animalcula Infusoria.
 (Vorti
 cella)
 (règne psychodiale).

— **Eithiere**, **Oozoa** (—
 Carl Gustav Carus,
 1832):
 Animalcula Infusoria

Archaeozoa (—
 Maximilian Perty, 1852):

Protozoa. () -

(Archezoa) 1 -

Microzoaires (Robert Whittaker, 1959). -

— Emile de Fromentel, 1874): -

((Prokaryota = Monera). -

((Peter Simon Pallas — 1) -

1741 1811) (Felix , 2) -

Dujardin — 1801 1860) -

Zoophyta Zoophytes Infusories -

) XIX (Margulis et al., -

1990). , Protoctista -

Phaeo -

phyta, Chytridiomycota, Oomycetes, Rho -

dophyta -

(Rudolf Leukart — 1822 1898) -

— **Protista** (-

— Ernst Haeckel, 1866): -

(1848). -

Acrita (— Richard Protista -

Owen, 1861): -

(*Closteri* -

) — Metazoa -

(Animalia) -

(Vegetabilia). : + -

= -

— **Protoctista** (-

— John Hogg, 1861): -

: Protozoa, Archezoa, Protocista
Protista¹.

« »,

¹ « »

(Hans & Zacharias Janssen)
1590
80
(Hans & Zacharias Janssen)
1676
80
animalcula.
1678
(Christian Huygens, 1629
1695).
1
(Delft),
400
XIX

¹ «simple microscope»
« »; a «compound microscope»
« ».



ANTONIUS A LEEUWENHOEK.

*Regia Societatis Londinensis
membrum.*

J. Verkolge pinx

A. de Blou fec

Рис. 1. Антон Левенгук, основатель научной микроскопии.

(Louis Joblot)

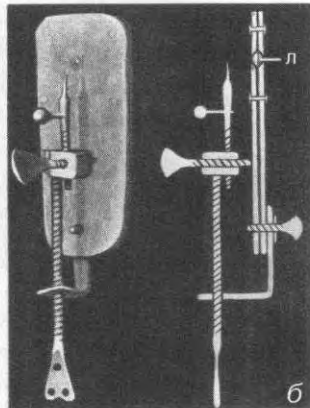

2.
1670 ().

(),
250 ()
().

1727

ratio spontanea), (gene 1749 -
 (George Buffon, -
 1707 1788) -
 (John Needham, -
 1713 1781). -
 , Animalcula -
 -
 Sperma- -
 tozoa, . . . -
 -
 (Lazzaro Spallanzani, 1729 1799) -
 -
 XIX , -
 -
 1805 , -
 -
 -
 Urthiere (-
), -
 ; -
 -
 -
 -
 -
 (Louis Pasteur, 1822

1895) (Robert Koch,
1843 1910).

1775

(Henry Baker)

1754

«

1768
1730 1784)

(Otho Fredericus Müller,

(. 3).

(Beiträge zu nützlichem und vergntigen
dem Gebrauch und Verbesserung des
Microscopii),

(1755)

(August

10

«

Johann Resel von Rosenhof).

»

(Carl

(Nikolas Theodore de Saussure)

von Linne, «Systema », 1758), . .

1769

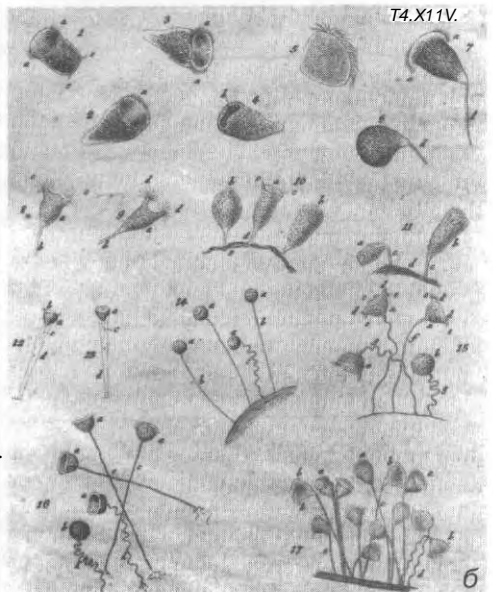
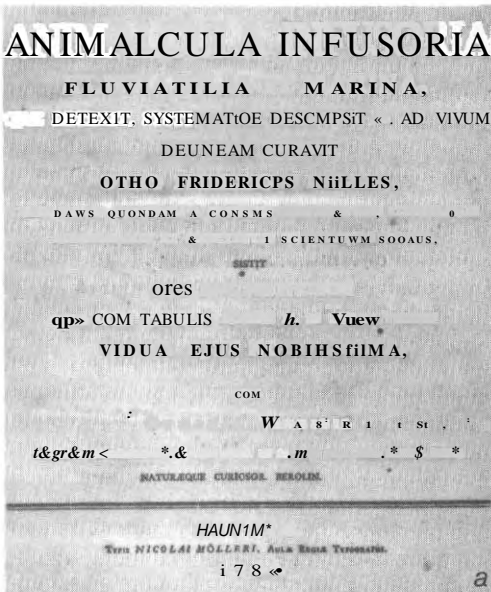

Monas, Ceratium hirudinella, Bursaria truncatella, Euplotes patella, Lacrymaria olor, Stylonychia mytilus.

XIX

XIX
(Jan Evangelista Purkinje, 1787 1869)
(Theodor Schwann, 1810 1882)
(Matthias Jacob Schleiden, 1804 1881)

?

(Alcide d'Orbigny, 1802 1857)

Foraminifera (

).

(Christian Gottfried Ehrenberg, 1795 1876),

Protista, 1873

() .

1835

« » (Die Infusionsthierchen als vollkommene Organismen, . 4)

(. .

«),

»,

(

),

(

)

Sarcodina Sarco

()

mastigophora,

(,) .

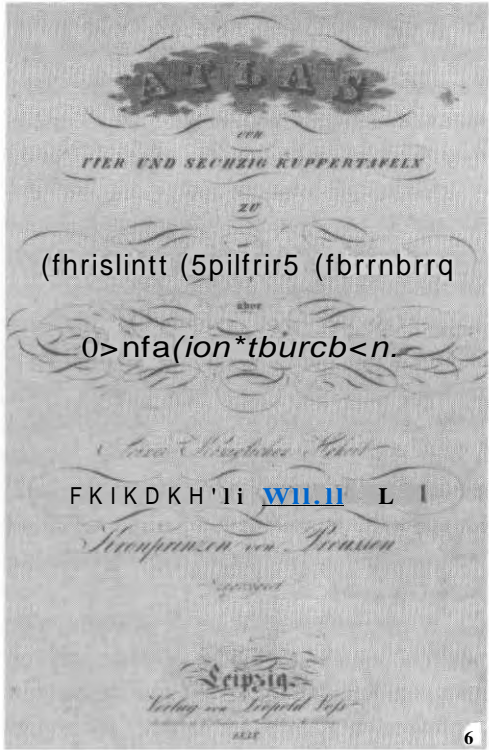
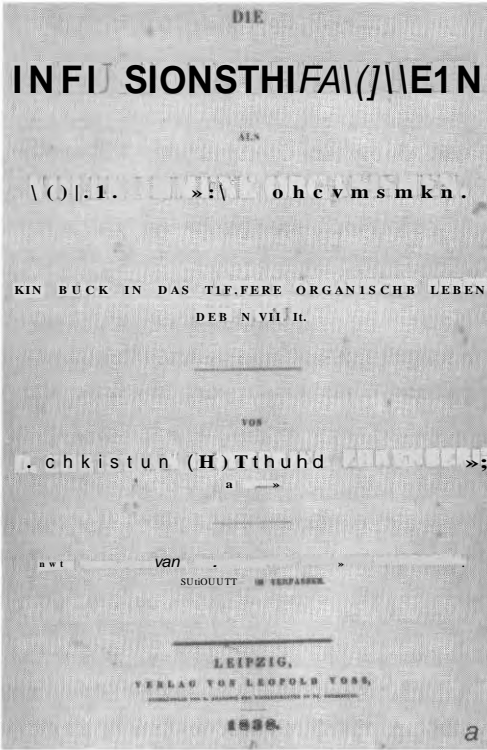

4.

()

()

- Chlamydomonas, Cryptomonas, Dinobryon, Euglena, Euplotes, Loxodes, Nassula, Peridinium, Prorodon, Spirostomum, Synura

1840

Actinophrys,
Amoeba, Arcella, Bodo, Carchesium,

Coccolithophorida. —

; -
 -
 (1859 1930), -
 ; -
 (George Klebs, 1857 1918)
 -
 ; -
 (Rudolf Leukart,
 1861 1822 1898), -
 Sporozoa; -
 (Max Schultze, 1825 1874), -
 (Fritz Richard Schaudinn, 1871 1906); -
 (Franz
 Eilhard Schulze, 1840 1917) -
 ; -
 4000 -
 ; -
 (Edouard Gerard
 Balbiani, 1823 1899)
 ; -
 (Otto Bütschli, 1848 1920), -
 (Heinrich Anton de , 1831 1888), -
 ; - (Clifford Dobell, 1951) « -
 (Charles Louis »
 Alphonse Laveran, 1845 1922), -
 () -
 1907 -
 ; -
 XIX
 (Edouard Claparede, 1832 1871), - 1879
 (Joseph Leidy)
 (Johannes Lachmann) 1888 (Alfred
 Stokes) -
 ; -
 (Wil-
 liam Savill Kent, 1845 1908) -
 « » XX -
 (Manual of the Infusoria); -
 (Richard Hertwig,
 1850 1937), -

1.

1:

(1675)

2:

(G.A. Goldfuss) (1818): Protozoa

(A. D'Orbigny) (1826): Foraminifera

X. (Chr. G. Ehrenberg) (1838):

3:

(. von Siebold) (1845):

(F. Dugardin) (1835) X. (. von Mohl) (1846)

(. Schultze) (1861, 1863): —

4:

(. Gruby) (1843):

Trypanosoma ()

(C.W. von Naegeli) (1857):

Nosema bombycis

(F. Lösch) (1875):

*histolytica**(Entamoeba*

P. (R. Leuckart) (1879):

Sporozoa

A. (A. Laveran) (1880):

(Plasmodium)

O. (. Bütschli) (1881):

Myxosporidia (= Myxozoa)

(G. Balbiani) (1882):

Microsporidia (= Microspora),
Sarcosporidia

(J.E. Dutton) (1902):

Trypanosoma gambiense —

5:

(. Bütschli),

(1878)

1.

- (F.E. Schulze), (1884)
- (R. Hertwig), (1885)
- (F. Schaudinn) (1902):
«Archiv für Protistenkunde», 1988
«Protist».
- (1904): Reichsge
sundheitsamt Berlin Lichterfelde, 1906
- Bernhard Nocht Institute)
- (1908)¹:
- (Hartmann) (1914):
Berlin Dahlem.
- 1947: — ; 1954
«Journal of Protozoology» (1993 «Journal
of Eukaryotic Microbiology»).
- 1963: «Acta Protozoologica»
- 1968: «Protistologica» (1987
«Journal of Protistology»)
- 1972:
(International Society of Evolutionary Protistology — ISEP)
- 1999: «Protistology»².
- 1961, :
4 : 1965 , 1969 -
, 1973 , 1977 , 1981 , 1985 -
, 1989 , 1993 , 1997 , 2001 -
/ , 2005 , 2009

(, 2001; Fokin, 2001). —

¹ 1922 1929
» (Archives de la Societe Russe de Protistologie),

: Hartmann,
A. Pascher, J. Oltmanns, Laveran, Chatton, R. Ross P. Manson. —

1900 (. . 26). XIX
(Gary Natan Calkins, 1901 1933), (. 5). XIX
(Franz Doflein, 1901, 1909, 1911, 1916), XIX : 1830
(Eduard Reichenov, 1929 1953) - 1830
(. 1).) ,
1880 , 1885 , 1932



Рис. 5. Год 1787: две страницы из каталога британского изготовителя микроскопов.

(Frits Zernike).

(Ernst Ruska)

1986

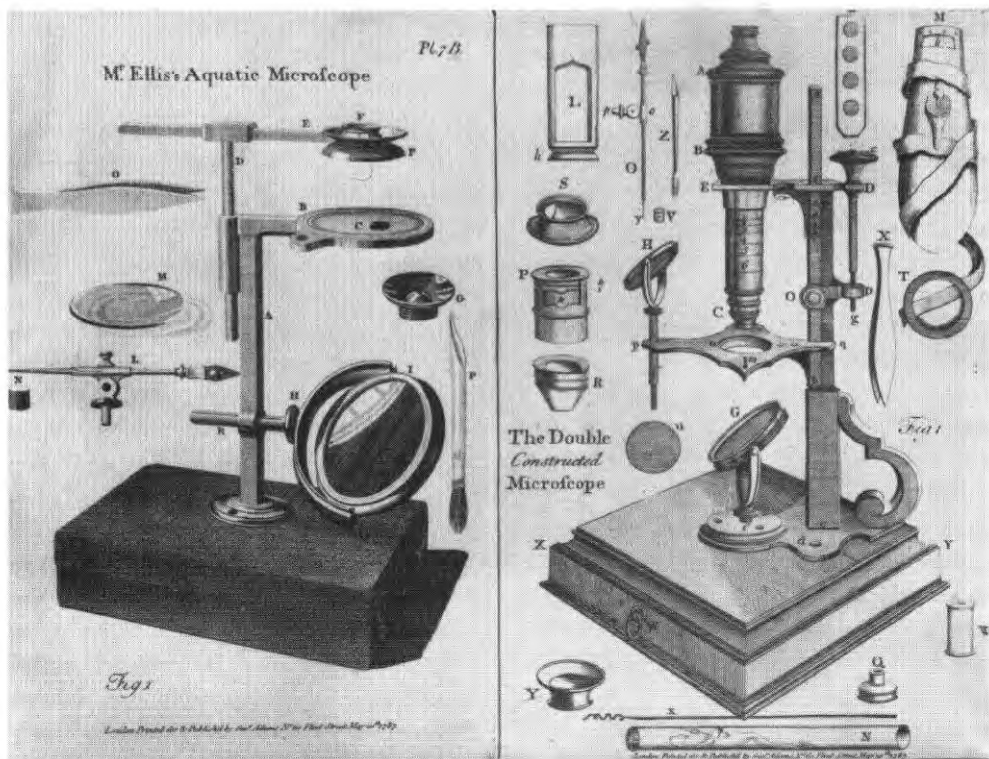
(Manfred von Ardenne)

1960

1950

(. 6, 7).

(. 8).

8).

(. 8).

(. 8,).

Entamoeba

Giardia,

Apicomplexa

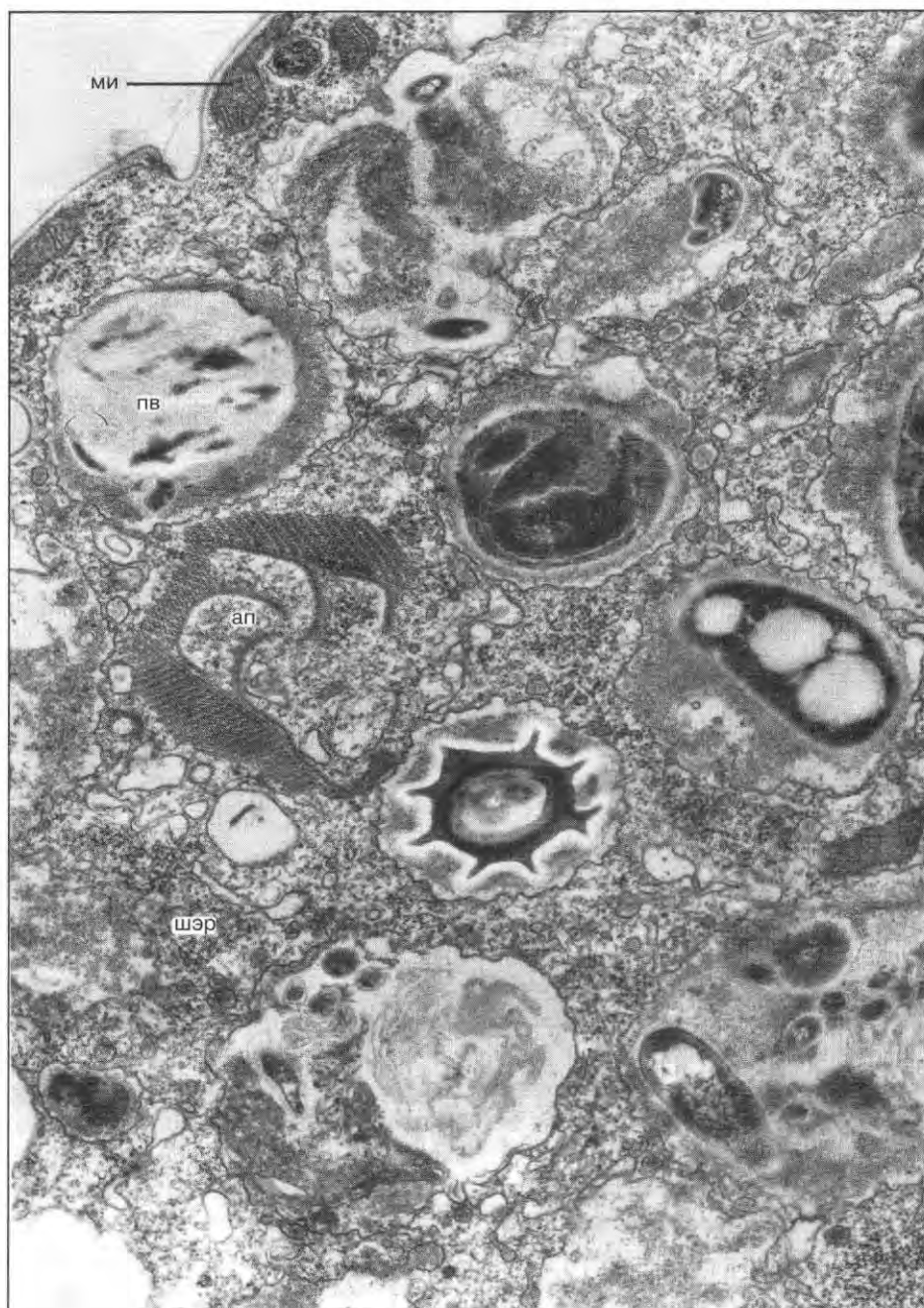

6.

Entosiphon sulcatum: an —

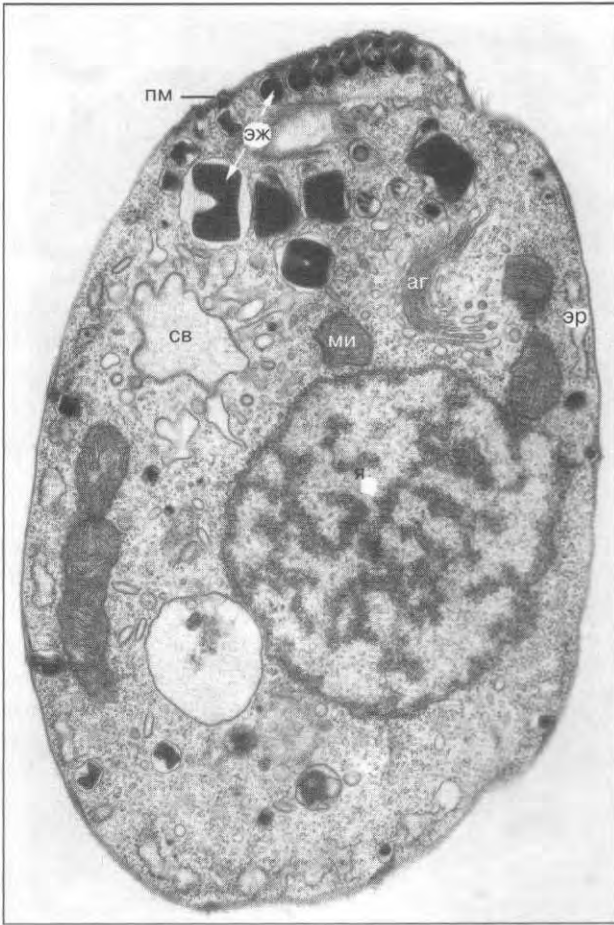

7. *Goniomonas*.
 (): — —
 , — —
 , — —
 — —
 , — —
 . :
 —
 —
 ,
 (—) (. 10),
 (. 11),
 (. 12) (. 13, 14),
 —
 —
 ,
 (. 9),
 ,
 (),
 :

Tetrahymena (Ciliophora)

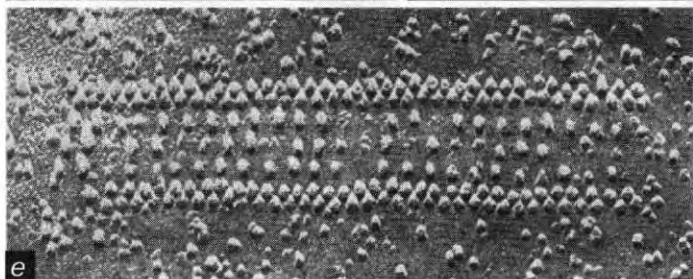
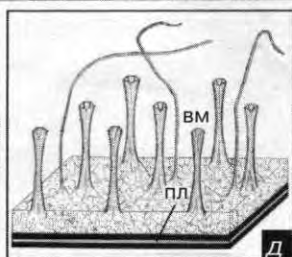
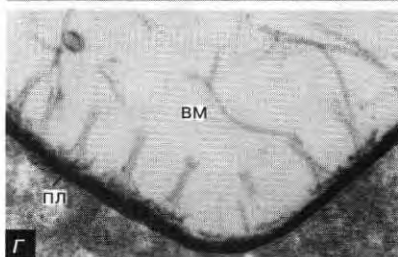
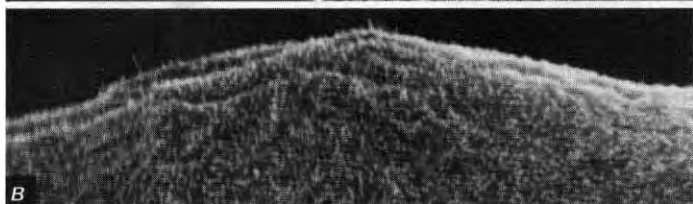
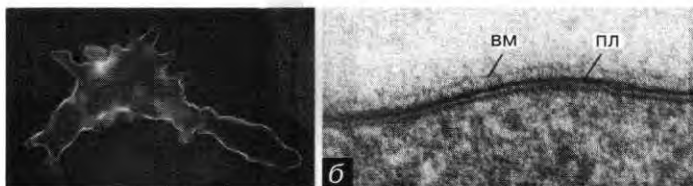

8.
 ()
 Amoeba proteus,
 FITC Con ();
 Vampyrella lateritia
 ()
 (); Vannella
 simplex
 (),
 ()
 ().
 Cyclidium () (—
 ; —
) . : — 150 ,
 6—185 , — 7 500 ,
 — 150 , —
 100 .

30

Trichonympha (Hypermastigida).

0,2 0,3

(. 15).

Trypanosoma brucei

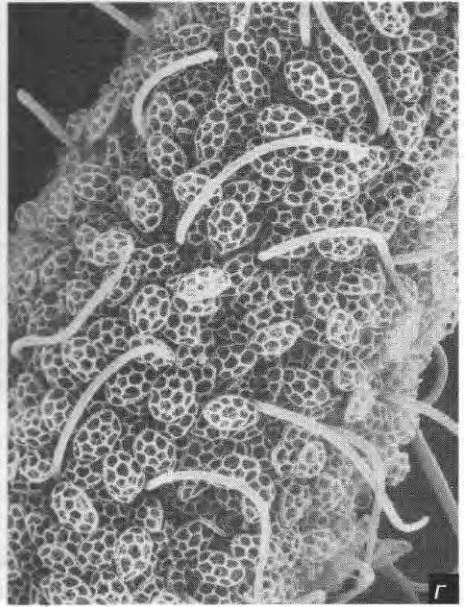
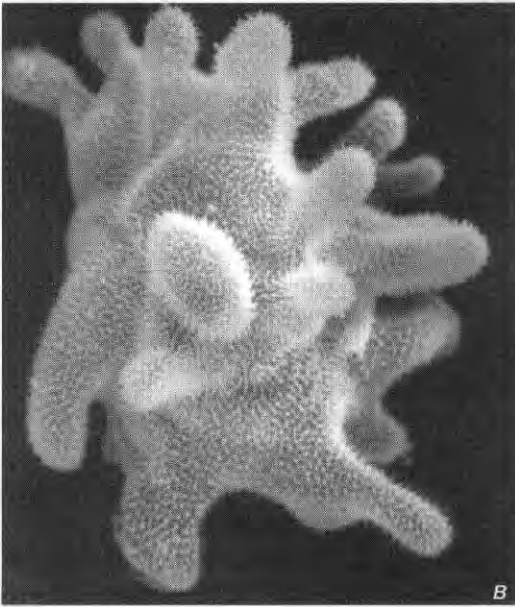
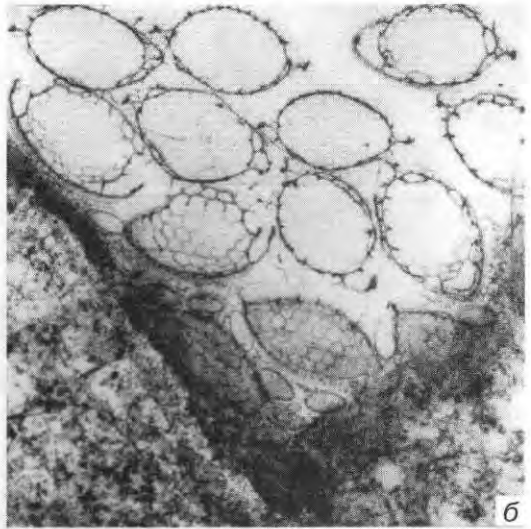
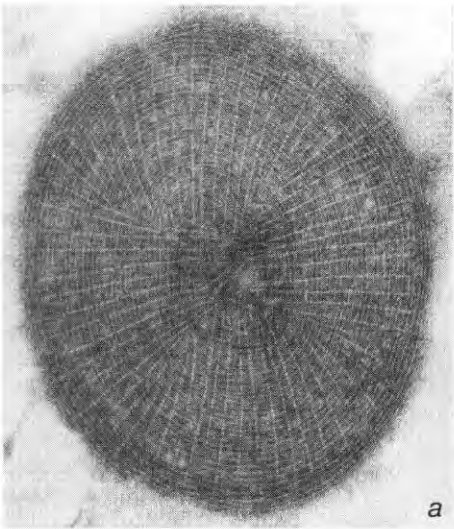

9.
Pleurochrysis ();
 ();

Cochliopodium (); *Dactylamoeba*,
Lepidotrachelophyllum () (—

1 800 , — 4 200) . . . — 77 , 6—28 , —

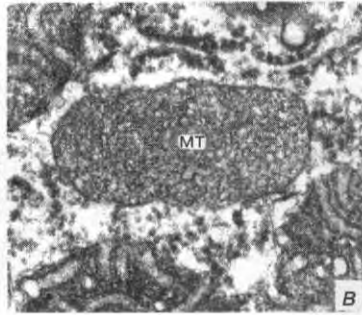
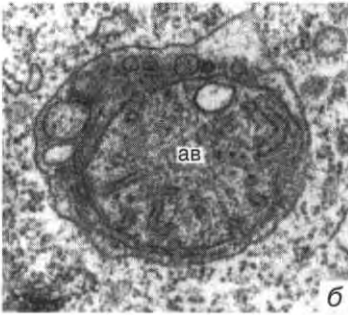
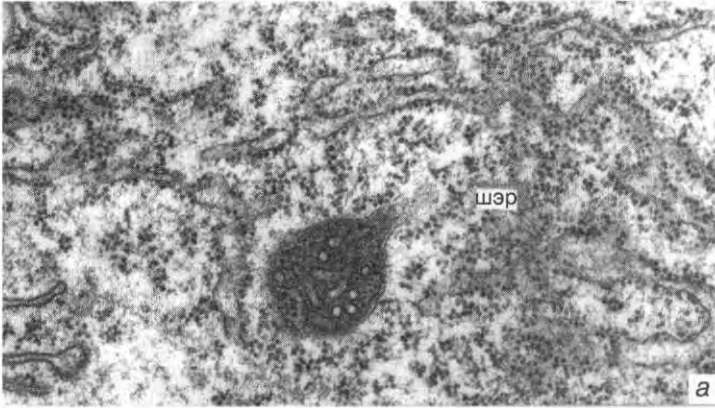

. 10.

Paramecium.

() () ;

()

() ;

() () .
— 25 , —
35 мкм, — 50 .

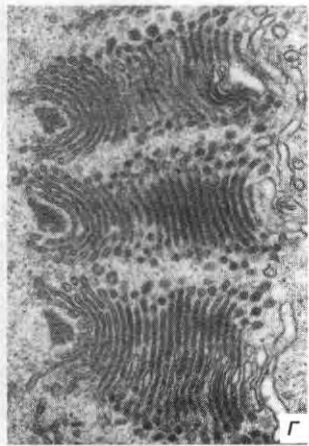
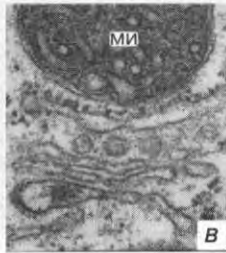
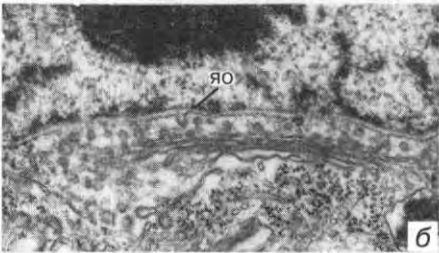
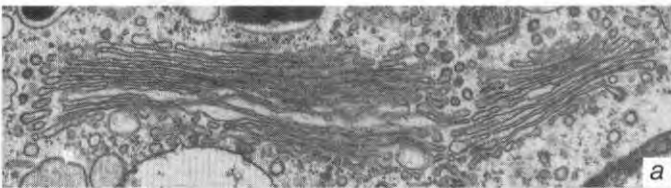

. 11.

Rhodomonas () ,

() ,

Pseudomicrothorax ()

Joenia () ,

— 25 , 6 — 25

— 50 , —

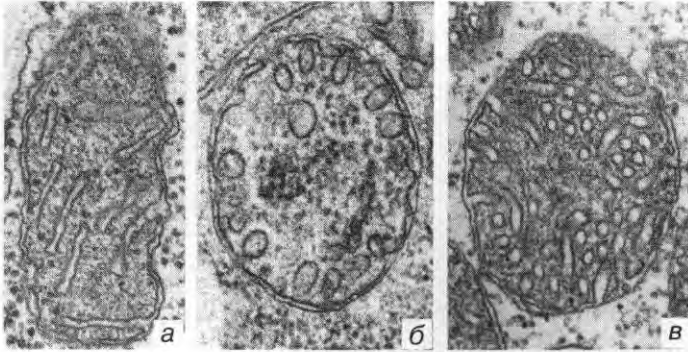

12. *monas* (), *Vampyrella lateritia* () *Gonio*
 : — 55 , 6 — 40 , — 60 *Paramecium caudatum* ().

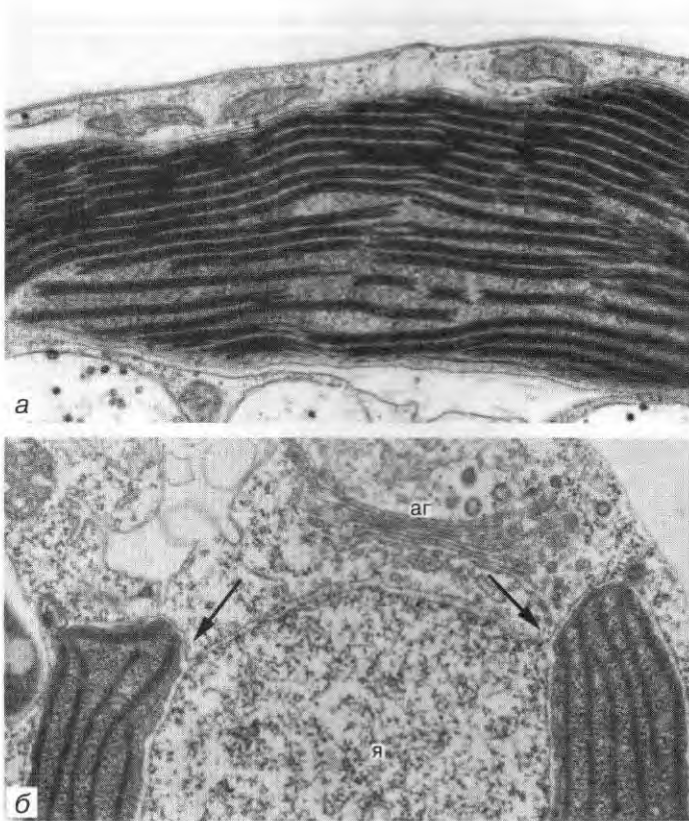

13. *Rhodomonas* (): —
) *Ochromonas* (), — (—
 : — 20 , — 18

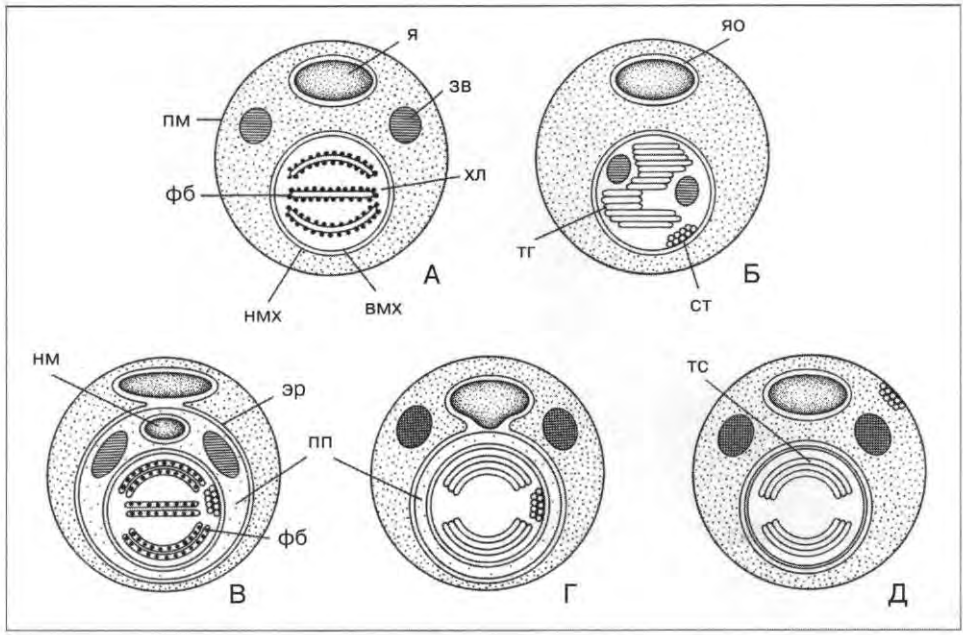

14.

(), (), Biliphyta
 (A), Chlorophyta (), Cryptomonada (), Chryomonadea () Euglenida ().

()
 ()
 4 ()
 (), ()
 ()
 ()
 ()
 2. — — ()

(15)

3

1
 1
 3

(13). —

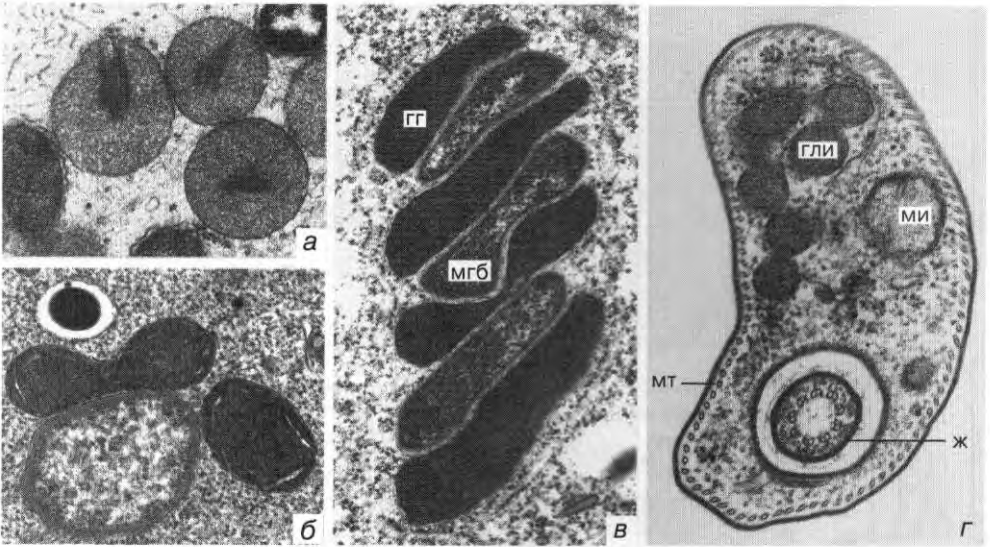

15. () *Joenia annectens* () *Metopus contortus* () *Plagiopila frontata* () () *Trypanosoma brucei* () — (— : Fenchel and Finley: Europ. J. Protistol. 26 [1991] 201).
 ∴ a — 25 000x, б — 35 , — 20 , — 35

(=) —
Entamoeba histolytica.
Entamoeba

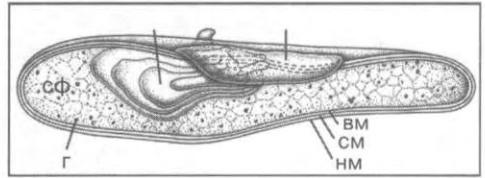

16.
Plasmodium falciparum.

Apicomplexa.

(apicoplast)
apicomplexan plastid ()
)

(16),

Apicomplexa.

35

« »

, « » «

»,

Toxoplasma *Plasmodium.*

mecium (. 17).
15

Para-

(. 14).

(. 18).

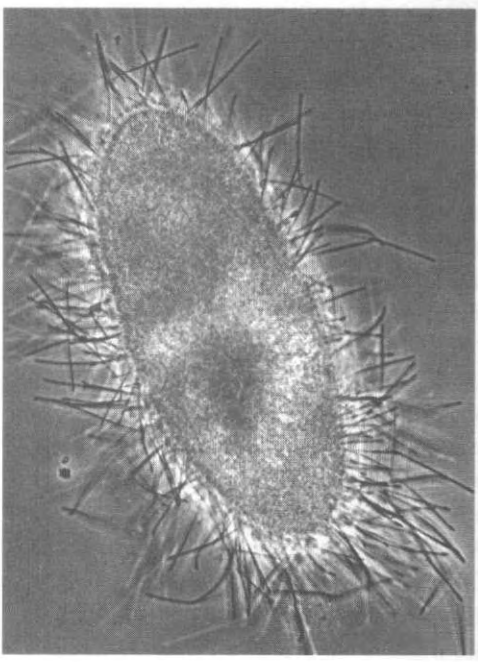

. 17.
mecium. : 500 .

Para-

(. . 112 306).

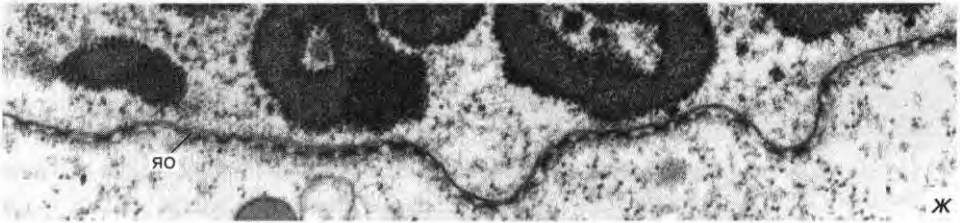
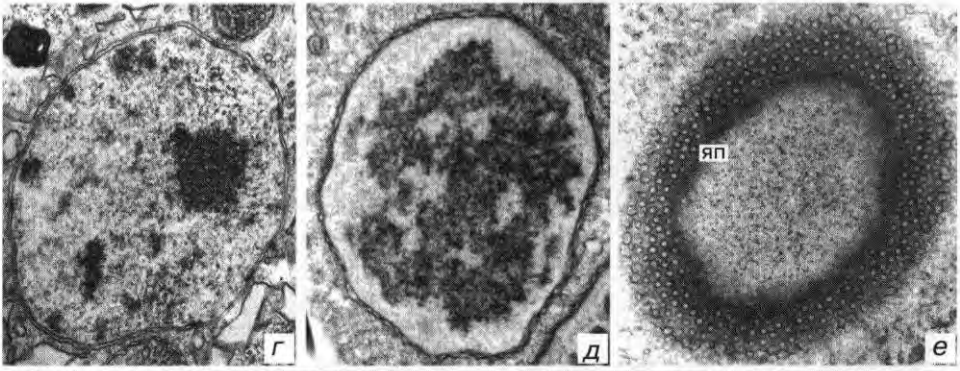
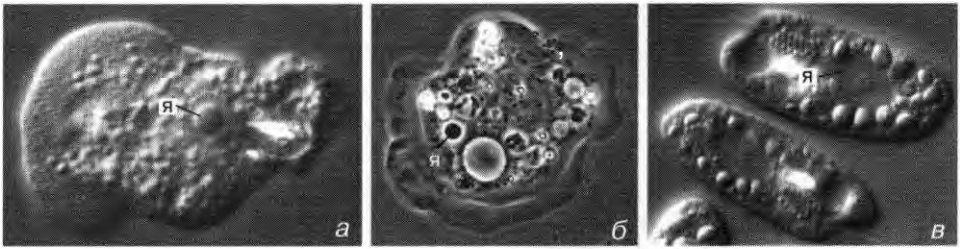

18. () *Vahlkampfia* () *Thecamoeba* () *Chilomonas* ()
 : *Vampyrella* (), *Pseudomicrothorax* (),
Staurojoenina
 (), () *Pseudomicrothorax*
 () (—
 ,) . : — 1800 , — , — 1800 , — 18 , — 14 , — 10 800 ,
 — 22 500 .

(. . 300).

(. 19)

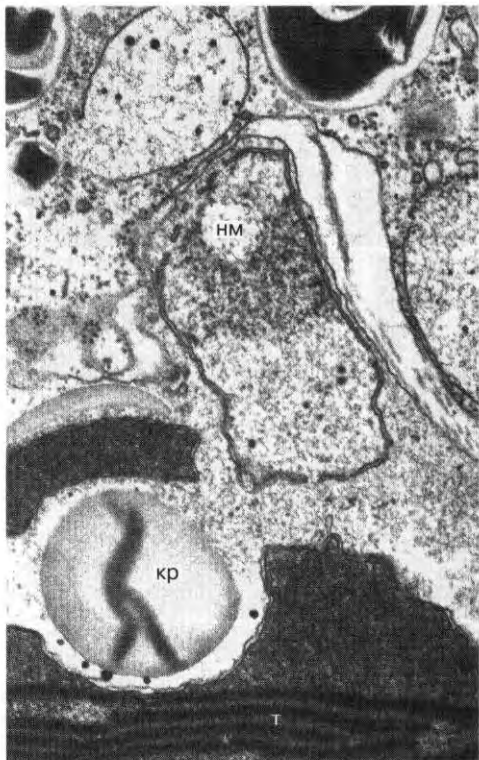

19. ()
Cryptomonas ovata.

: 35

4 10

(. 20).

Stentor

(. 21).

(. 226,)

Paramecium.

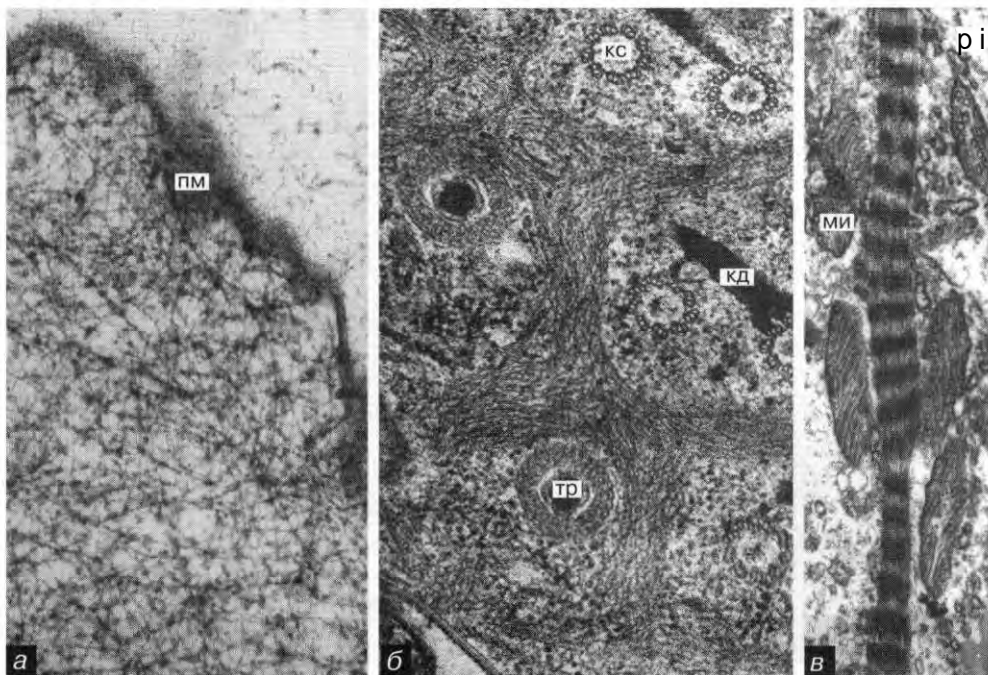

20. *Amoeba proteus* () *Paramecium caudatum*
 () *Loxophyllum meleagris* (), — , — , — , —
 — , — , — (— , —)
). : — 115 000 , 6 — 57 , — 19 .

(. 22, 23) -

(. 154)

(Lobosa: *Amoeba*, *Mayorella*,
Nebela, *Saccamoeba*, *Stereomyxa*; Hetero
 lobosa, Conosa, Mesomycetozoa);

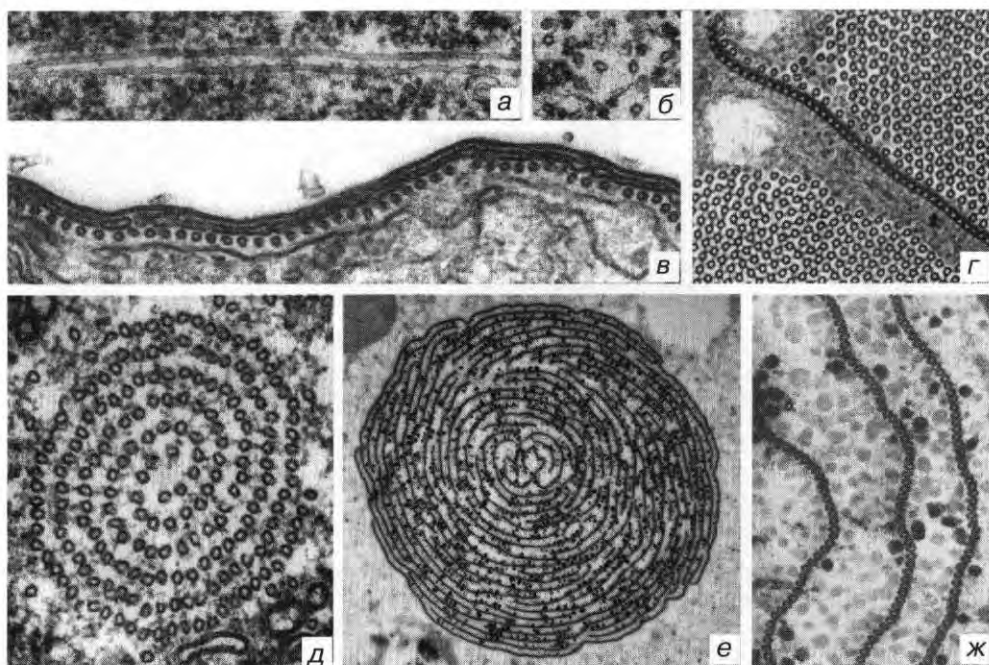

. 21. () () -
Paramecium.
Euplotes (). *Nassula* (). -
Actinophrys (). *Joenia*
(,). : , - 38 , - 43 , - 33 , - 76 , - 7500 , - 30 .

(Aconchulina: *Nuclearia*, *Hyalodiscus*;
Protostelea; Cercozoa: *Cyphoderia*; Hete
rokonta: *Labyrinthulea*, *Chrysonomadea*;
Chytridiomycota);

(Acantharea,
Polycystinea, *Phaeodarea*,
Actinophrys);

(Foraminifera: *Allogromia*, *Reticulomyxa*);

(Aconchulina: *Hyalodiscus*;
Lobosa: *Vannella*);

).

Hyalodiscus,

Foraminifera,

+
cystinea

Acantharea, Poly-

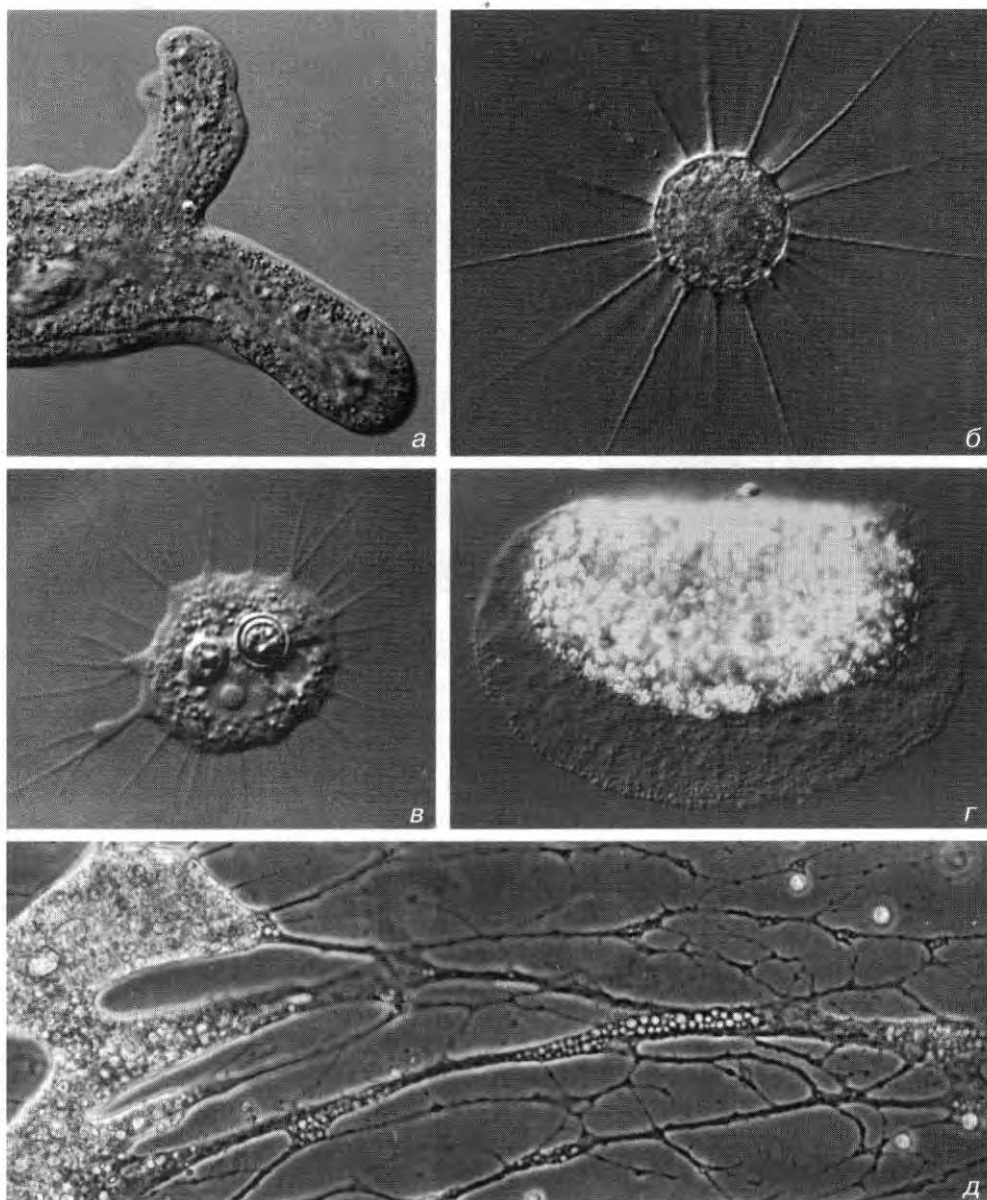

22. : *Amoeba proteus* (), *Actinophrys sol* (),
Nuclearia (), *Hyalodiscus predatus* (), *Reticu*
lomyxa filosa () (— , — 580 , — 875 , — 175 .) . . : — 580 ,

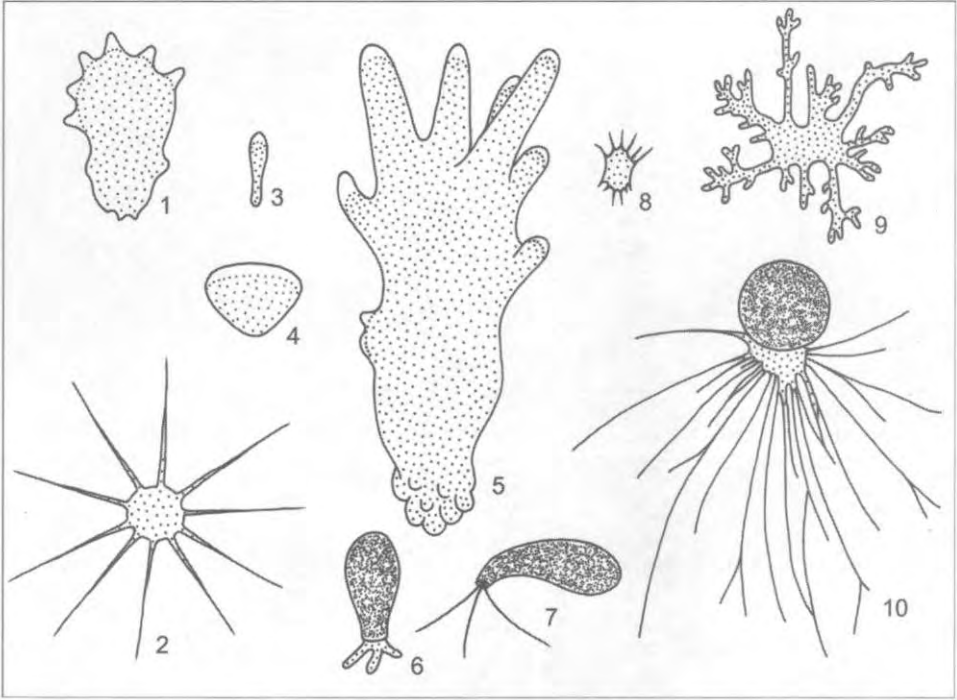

23. () 1 —
 {Mayorella}, 2 — (Actinophrys¹), 3 —
 (Saccamoeba), 4 — (Vannella), 5 —
 (Amoeba), 6 — (Nebela), 7 —
 (Cyphoderia), 8 — (Nuclearia), 9 — (Stereomyxa), 10 —
 (Allogromia²).

9x2+2

(. 36).

Tetra

¹ Actinophrys

² Allogromia

Allogromia

Foraminifera

Gromia

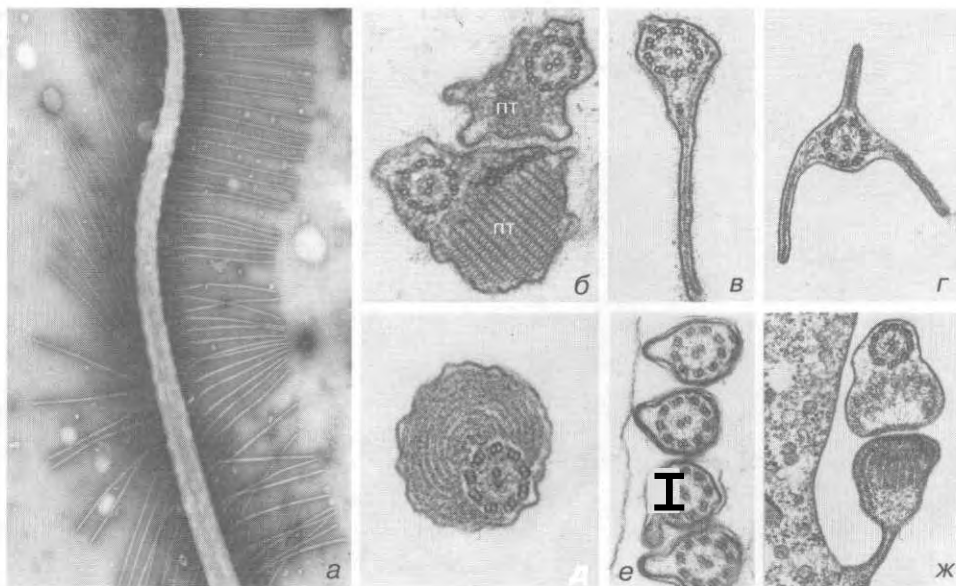

. 24. () Entosiphon (), ()
 Retortamonas () Colponema loxodes ()
 Stylonychia () Foaina ()
 Tritrichomonas angusta () (—
 ; —) . : — 16 , 6 — 36 , , , —
 32 , — 40 , —28 .

(. 25).

(. 24),
 (. 168).

(. 26).

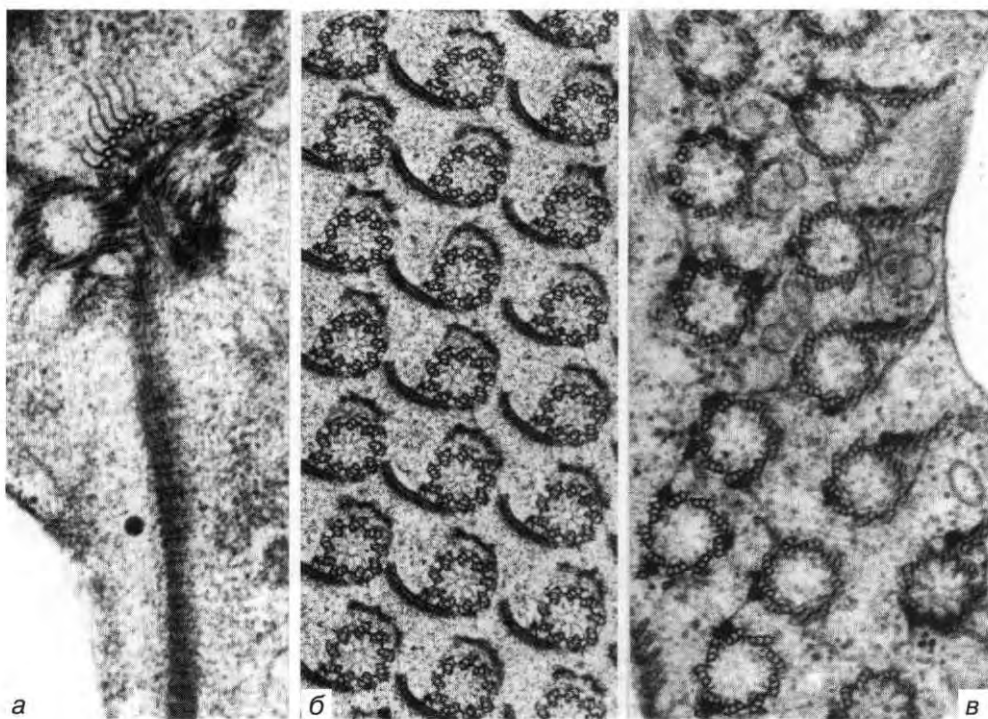

25. *Chilomonas* (), *Joenia* () *Eufolliculina* ().
 65, 6 — 48, — 65

(. 27):

28).

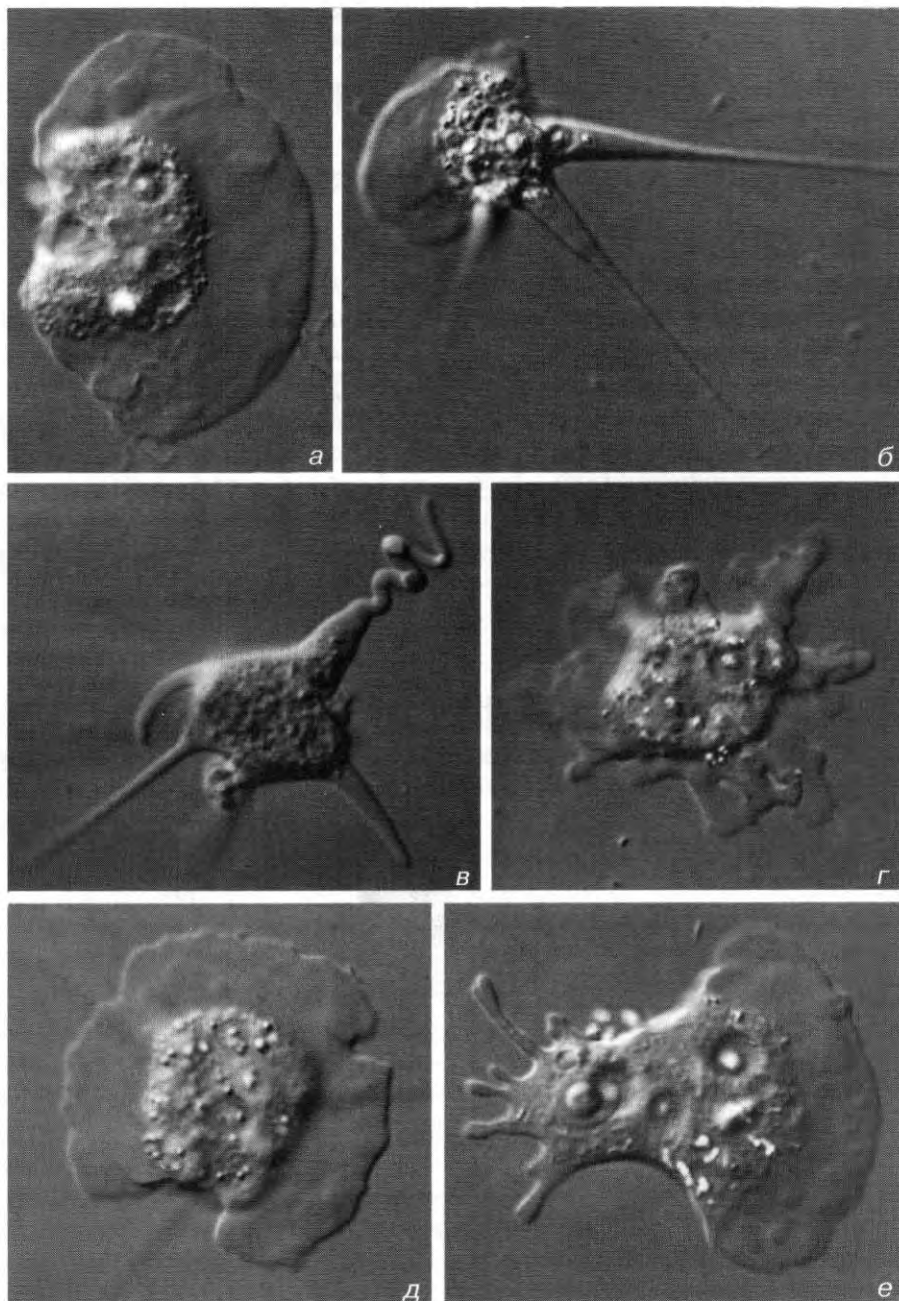

. 26.

«

Vannella simplex.
 (). .: 930 .

()

(,),

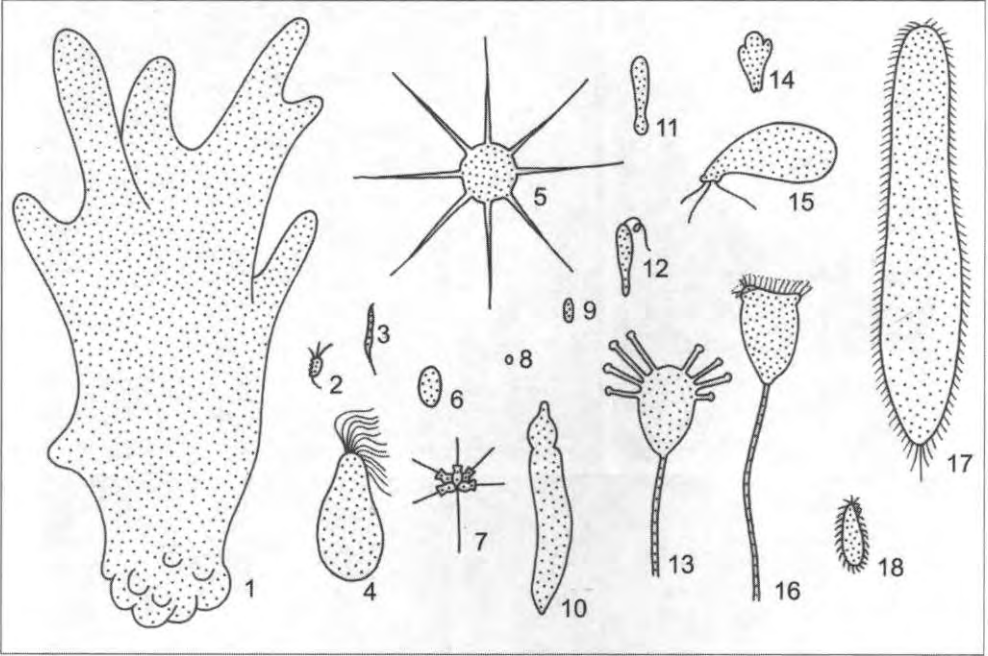

. 27.

(
). 1 — *Amoeba*, 2 — *Trichomonas*, 3 — *Trypanosoma*, 4 — *Joenia*, 5 — *Actinophrys*, 6 — *Eimeria*, 7 — *Codonosiga*, 8 — *Microspora*, 9 — *Myxozoa*, 10 — *Gregarina*, 11 — *Saccamoeba*, 12 — *Euglena*, 13 — *Discophrya*, 14 — *Entamoeba*, 15 — *Trinema*, 16 — *Vorticella*, 17 — *Paramecium*, 18 — *Tetrahymena*.



. 28.

Physarum polycephalum,
 5,54²,

1 ()
 ,)

II.

2500 1500

4550

4000

13 / 12

, -
 , -
 , -
 , -
 , -
 (, -
);
 • 02 -
 () -
 —
 « » («soda »);
 • 2*
 (10~7
 10-2), -
 ;
 • 10 (-
 7 8);
 •
 •
 •
 •
 • ();
 • , -

29.

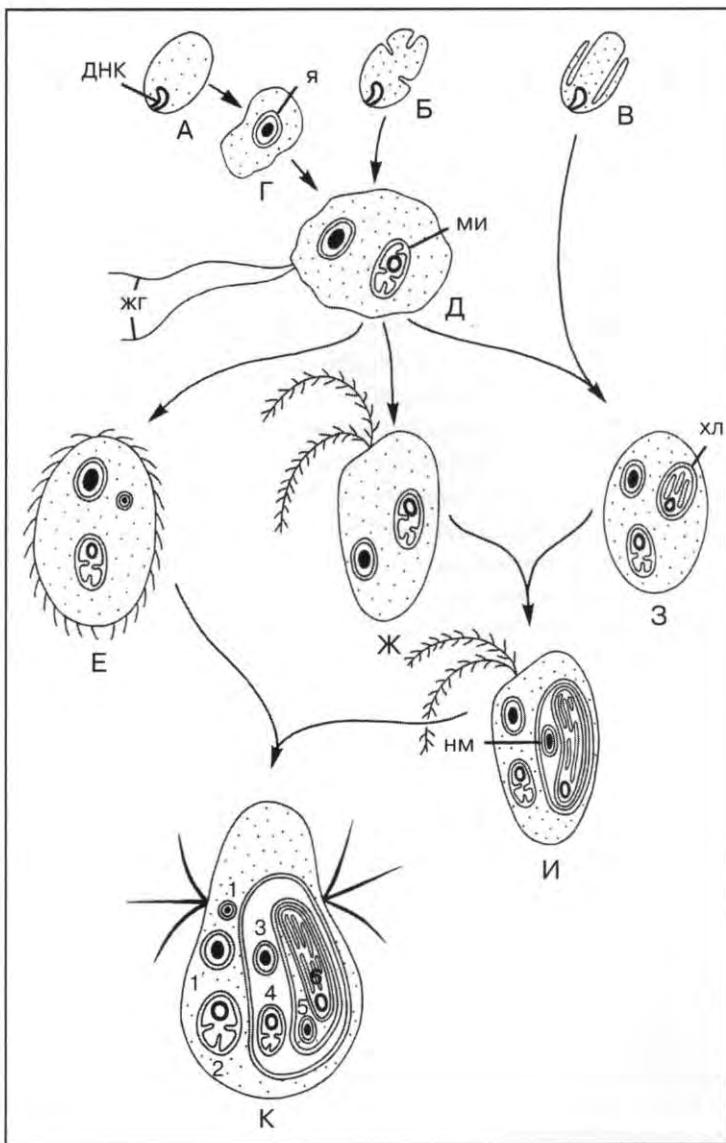

Myrionecta (= Mesodinium) rubra,

()
 ()
 1 —
 ; ()
 2 —
 ; ()
 3 —
 ; ()
 —
 () ; ()
 ()
 (=) ; ()
 ; ()
 ()
 () ;
 (3)
 ()
 ()
 ; ()
 ; ()
 1 —
 , 4 —
), 6 —

()
 : 1 —
 , 3 —
 ()
 —
)

2 —
 , 5 —
 ;
 ()

()

. 30. ()

(HP) — () — (2),

(3). + —

() (Eus) (D), (Chr),

4 (+ 1) ; + + —

(«.» «R>s), (Ci Cis), (Fo

()). 5.

Biliphyta (Bi), Chlorobionta (Ch), Phaeophyta (Ph),
(/ — Ascomycota/Basidiomycota) Metazoa (hMz) (

).

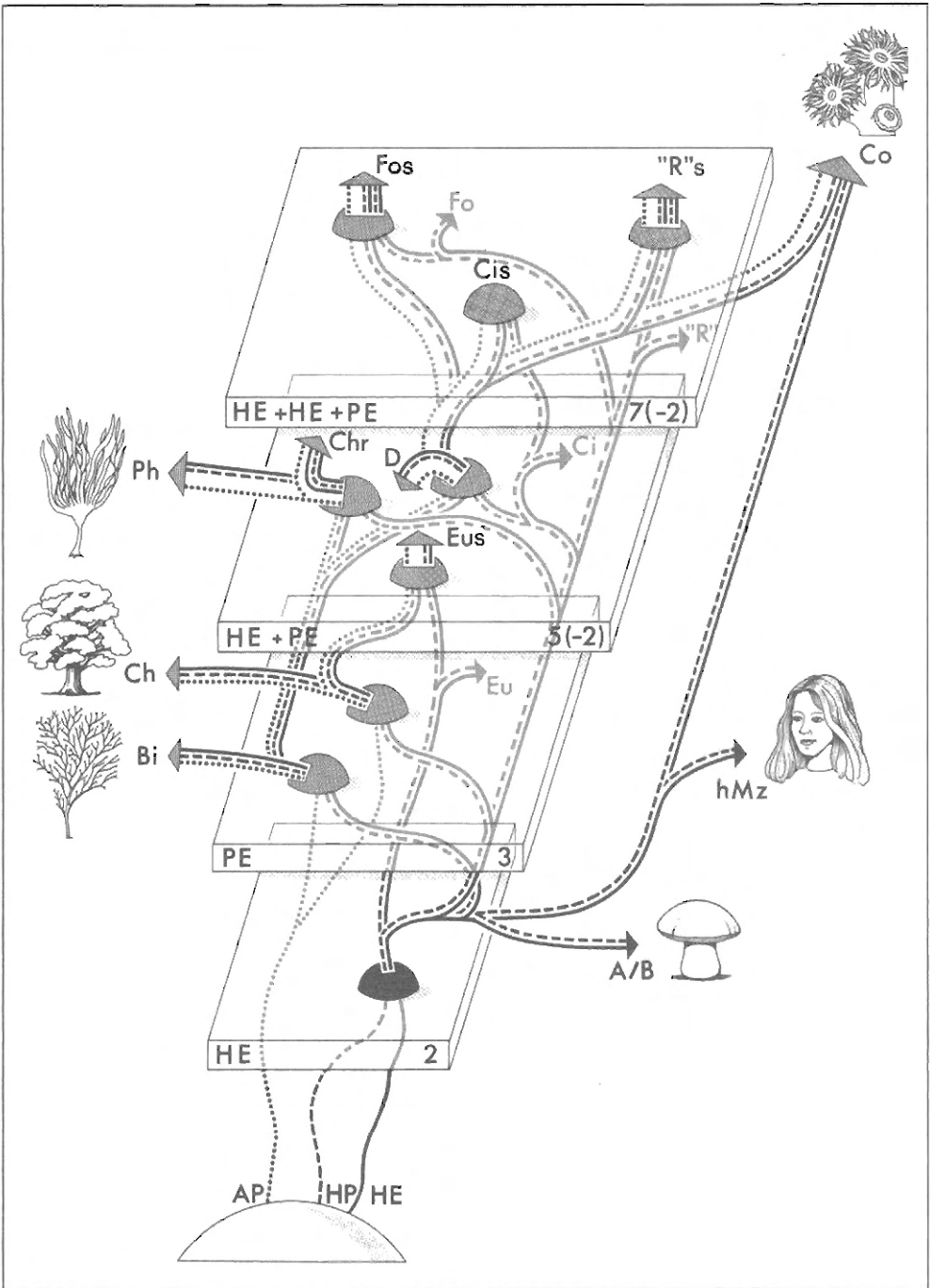

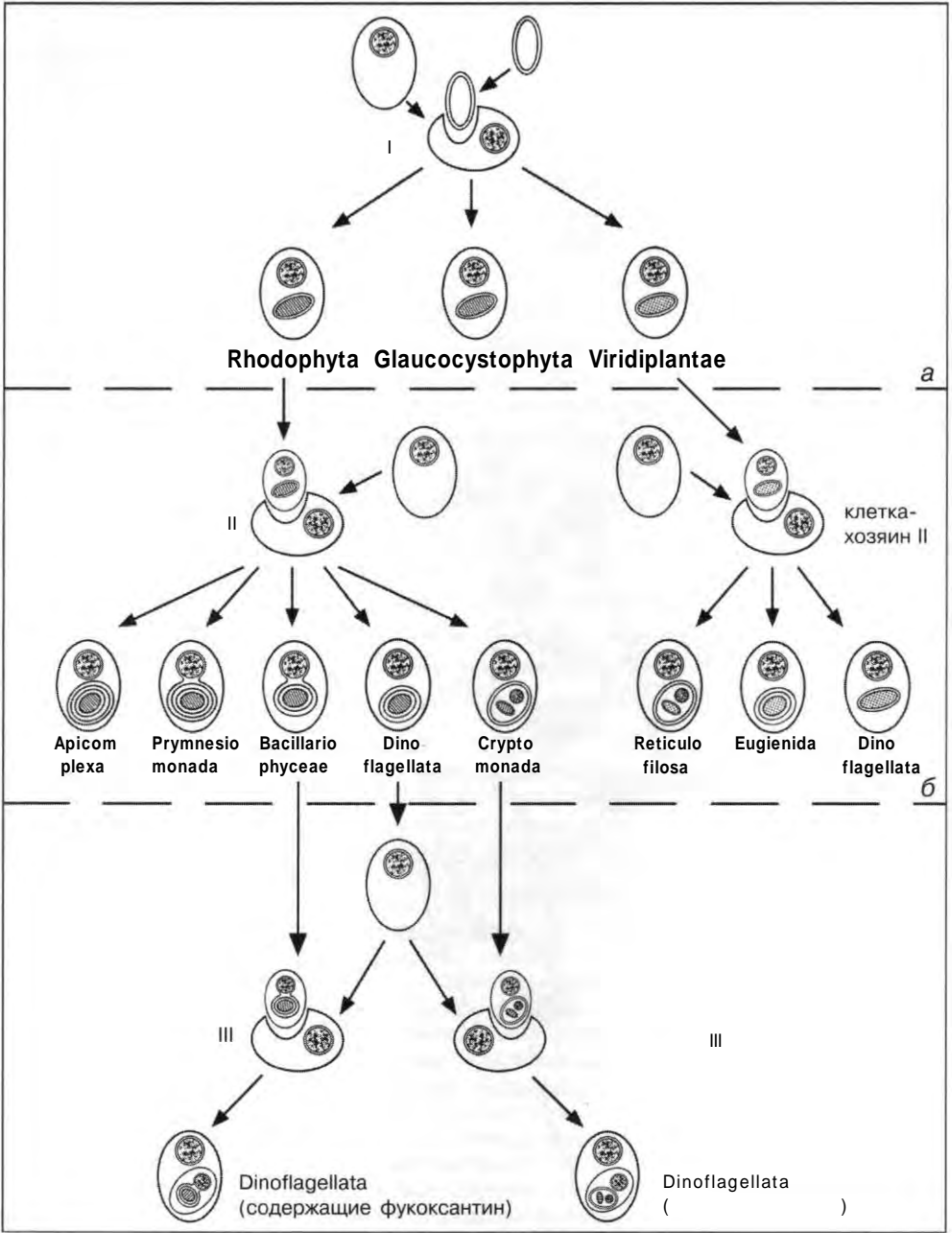

Chlorophyta,
Rhodophyta Glaucocystophyta (. 30).

31.

(= Chlorobionta), Rhodophyta Glaucocystophyta.

Viridiplantae

(.) .

Parabasalia

1

(. . . 33).

70S

- Sporozoa Leuckart, 1879; Acantharea
 - Haeckel, 1881; Myxosporidia Biitschli,
 1881.

Protozoa (. 2).

2. 1889

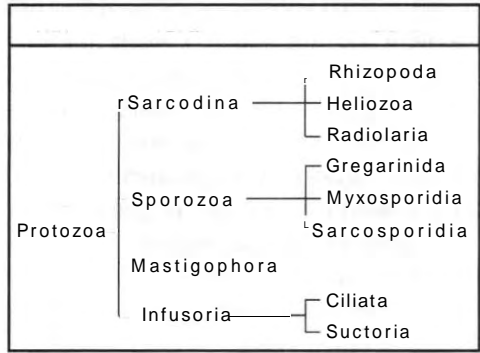

XXI

Animalcula, Infu-

soria.

1964

3.

(1842

3.

1964

: Polycystinea Ehrenberg,
 1838; Rhizopoda von Siebold, 1845;
 Ciliata Perty, 1852; Flagellata Cohn, 1853;
 Radiolaria J. Mtiler, 1858; Suctoria Clapa
 rède et Lachmann, 1858/59; Mycetozoa de
 , 1859; Heliozoa Haeckel, 1866;
 Mastigophora Diesing, 1866; Sarcodina
 Schmarda, 1871; Filosea Leidy, 1879;

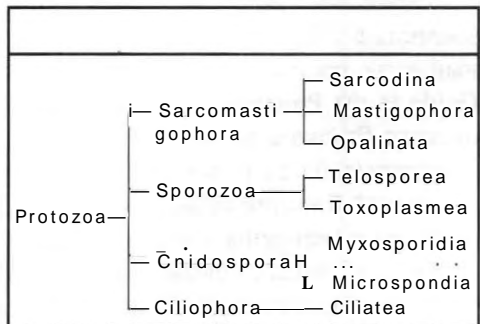

- « » (Hand-
 - book of Protoctista),
 Sporozoa Cnido 1990 , ,
 spora () - , -
 Sporozoa (Protoctista, -
), Mastigo- , 35 -
 phora Sarcodina - (. 6). -
 Sarcomastigophora. , -
 - Protozoa,
 -
 - (Rhodophyta, Phaeophyta,
 Chlorophyta) (Hypho
 chytridiomycota, Plasmodiophoromycota,
 Chytridiomycota Oomycota). (-
) 1980) -
 (, -
 15) , -
 / -
 Protozoa (. 4). -
 4. -
 1980 -

: Protozoa	
1.	Sarcomastigophora Honigberg & Balamuth, 1963
2.	Labyrinthomorpha Page, 1980
3.	Apicomplexa Levine, 1970
4.	Microspora Sprague, 1977
5.	Ascetospora Sprague, 1978
6.	Myxozoa Grasse, 1970
7.	Ciliophora Doflein, 1901

(1996), , -
 -
 1985 « -
 » (The Illustrated
 Guide to the Protozoa) , -
 Protozoa 6 28
 (. 5). (. 7). (1998)
 (1980) , -
 « -
 » (The Illustrated Guide to the
 Protozoa, 2000),

5.

» 1985

Protozoa (Goldfufl, 1818) von Siebold, 1846

- Sarcomastigophora Honigberg & Balamuth, 1963
- Mastigophora Diesing, 1866
 - Phytomastigophorea Calkins, 1909
 - Zoomastigophorea Calkins, 1909
- Opalinata Corliss & Balamuth, 1963
 - Opalinatea Wenyon, 1926
- Sarcodina Schmarda, 1871
 - Rhizopodea von Siebold, 1845
 - Lobosea Carpenter, 1861
 - Acarpomyxea Page, 1976
 - (Acrasea Schröter, 1886)
 - Mycetozoea de Bary, 1859
 - (Plasmodiophorea Cook, 1928)
 - Filosea Leidy, 1879
 - Granuloreticulosea de Saedeler, 1934
 - (Xenophyophorea Schulze, 1904)
 - Actinopodea Calkins, 1902
 - Acantharea Haeckel, 1881
 - Polycystina (Ehrenberg, 1838) Riedel, 1967
 - Phaeodarea Haeckel, 1879
 - Heliozoa Haeckel, 1866
- Labyrinthomorpha Page, 1980
 - (Labyrinthulea Levine & Corliss, 1963)
- Apicomplexa Levine, 1970
 - Perkinsida Levine, 1978
 - Sporozoasida Leuckart, 1879
- Microspora Sprague, 1969
 - Metchnikovellidea Weiser, 1977
 - [Rudimicrosporea Sprague, 1977]
 - Microsporididea Corliss & Levine, 1963
 - [Microsporea Delphy, 1963]
- Myxozoa Grasse, 1970
 - Myxosporea Butschli, 1881
 - Actinosporea Noble, 1980
- Ciliophora Doflein, 1901
 - Postciliodesmatophora Gerassimova & Seravin, 1976
 - Karyorelictica Corliss, 1974
 - Spirotrichea Butschli, 1889
 - Rhabdophora Small, 1976
 - Prostomatea Schewiakoff, 1896
 - Litostomatea Small & Lynn, 1981
 - Cyrtophora Small, 1976
 - Phyllopharyngea de Puytorac et al., 1974
 - Nassophorea Small & Lynn, 1981
 - Oligohymenophorea de Puytorac et al., 1974
 - Colpodea de Puytorac et al., 1974

6.

1990

Protoctista (Hogg, 1861) Margulis & Schwartz, 1988	
I	
1. Rhizopoda	Lobosea Filosea
2. Haplosporidia	Haplosporea
3. Paramyxea	Paramyxidea Marteiliidea
4. Myxozoa	Myxosporea Actinosporea
5. Microspora	Rudimicrosporea Microsporea
II	
6. Acrasea	Acrasida
7. Dictyostelida	Dictyostelida
8. Rhodophyta	Rhodophyceae
9. Conjugatophyta	Conjugatophyceae
III	
10. Xenophyophora	Psamminida Stanomida
11. Cryptophyta	Cryptophyceae
12. Glaucocystophyta	Glaucocystophyceae
13. Karyoblastea	Karyoblastea
14. Zoomastigina	Amoebomastigota

Bicoecida	
Choanomastigota	
Diplomonadida	
Pseudociliata	
Kinetoplastida	
Opalinata	
Proteromonadida	
Parabasalia	
Retortamonadida	
Pyrsonymphida	
15. Euglenida	Euglenophyceae
16. Chlorarachnida	Chlorarachniophyceae
17. Pymnesiophyta	Pymnesiophyceae
18. Raphidophyta	Raphidophyceae
19. Eustigmatophyta	Eustigmatophyceae
20. Actinopoda	Polycystina Phaeodaria Heliozoa Acantharia
21. Hyphochytriomycota	Hyphochytrida
22. Labyrinthulomycota	Labyrinthulida Thraustochytrida
23. Plasmodiophoromycota	Plasmodiophorida
IV	
24. Dinoflagellata	Dinophyceae Syndiniophyceae
25. Chrysophyta	Chrysophyceae Pedinellophyceae Dictyochophyceae (= Silicoflagellata)
26. Chytridiomycota	Chytridiomycetes
27.	Protostelida Myxomycotina

6.

28. Ciliophora	Karyorelictea
	Spirotrichea
	Prostomatea
	Litostomatea
	Phyllopharyngea
	Nassophorea
	Oligohymenophorea
	Colpodea
29. Granuloreticulosa	Athalamea
	Foraminifera
30. Apicomplexa	Gregarinia
	Coccidia
	Haematozoa
31. Bacillariophyta	Coccinodiscophyceae

	Fragilariophyceae
	Bacillariophyceae
32. Chlorophyta	Prasinophyceae
	Chlorophyceae
	Ulvoephyceae
	Charophyceae
	4
33. Oomycota	Saprolegniomycetidae
	Peronosporomycetidae
34. Xanthophyta	Xanthophyceae
35. Phaeophyta	Phaeophyceae
36. incertae sedis:	Ellobiopsida
	Ebriida

7.

1996

Eukaryota	Microspore				
	Mastigota	Archamoebaea			
		Dimastigota	Tetramastigota	Retortamonada	
				Axostylata	
			Euglenozoa		
			Heterolobosa		
			Dictyostela		
			Protostela		
			Myxogastrea		
			Chromista		
			Metakaryota	Alveolata	
				Choanoflagellata	
				Chlorophyta	
				incertae sedis	Amoebozoa
Granuloreticulosa					
Actinopoda					
Ascetospora					
Myxozoa					

Protozoa

- Archezoa Cavalier Smith, 1983
 - Metamonada (Grasse, 1952) Cavalier Smith, 1981
 - Eopharyngia Cavalier Smith, 1993
 - Axostylaria (Grasse, 1952) Cavalier Smith, 1997
 - Trichochozoa Cavalier Smith, 1997
 - Anaeromonada Cavalier Smith, 1997
 - Parabasala (Honigberg, 1973) Cavalier Smith, 1997
- Neozoa Cavalier Smith, (1993), 1997
 - Sarcomastigota Cavalier Smith, 1983
 - Neomonada Cavalier Smith, 1997
 - Apusozoa Cavalier Smith, 1997
 - Isomita Cavalier Smith, 1997
 - Choanozoa Cavalier Smith, (1981), 1983
 - Cercozoa Cavalier Smith, (1995, 1997), 1998
 - Phytomyxa Cavalier Smith, 1997
 - Reticulofilosa Cavalier Smith, 1997
 - Monadofilosa Cavalier Smith, 1997
 - Foraminifera (d'Orbigny, 1826) (Eichwald, 1830), Margulis 1974
 - Amoebozoa Lühe, 1913
 - Lobosa (Carpenter, 1861) Cavalier Smith, 1997
 - Conosa Cavalier Smith, 1998
 - Archamoeba Cavalier Smith, 1983
 - Mycetozoa de Bary, 1859
 - Eumyxa Cavalier Smith, 1993
 - Dictyostelia Lister 1909
 - Discicristata Cavalier Smith, 1998
- Percolozoa Cavalier Smith, 1991
 - Tetramitia Cavalier Smith, 1993
 - Pseudociliata Cavalier Smith, 1993
- Euglenozoa Cavalier Smith, 1981
 - Plicostoma Cavalier Smith, 1998
 - Saccostoma Cavalier Smith, 1998
- Alveolata Cavalier Smith, 1991
- Miozoa Cavalier Smith, 1987
- Dinozoa Cavalier Smith, 1981
 - Protalveolata Cavalier Smith, 1991
 - Dinoflagellata (Butschli, 1885) Cavalier Smith, 1991
- Sporozoa (Leuckart, 1879) Cavalier Smith, 1981
 - Gregarinae (Haeckel, 1866) Cavalier Smith, 1998
 - Coccidiomorpha (Doflein, 1901) Cavalier Smith, 1993
 - Manubrispora Cavalier Smith, 1998
 - Heterokaryota (Hickson, 1903) Cavalier Smith, 1993
- Ciliophora (Doflein 1901, Copeland 1956) Cavalier Smith, 1998
 - Tubulicorticata de Puytorac et al., 1992
 - Epiplasmata de Puytorac et al., 1992
 - Filocorticata de Puytorac et al., 1992
- Actinopoda (Calkins 1902) Cavalier Smith, 1997
- Heliozoa (Haeckel, 1886) Margulis, 1974
- Radiozoa Cavalier Smith, 1987
 - Spasmaria Cavalier Smith, 1993
 - Radiolaria (Miiller, 1858) Cavalier Smith, 1993

9.

» 2000

«

	Choanoflagellata Microsporida Myxozoa Volvocida	
	Apicomplexa Colpodellidae Ciliophora Dinozoa	
	Chryomonada Pelagophyceae Raphidomonadida « Slopalinida Synurophyceae Silicoflagellata »	« »
	Acantharia « Arcellinida Heliozoa Granuloreticulosea Mycetozoa Phaeodaria Polycystina » « Schizocladidae » « Trichosidae Xenophyophorea »	« » « » « »
	Pelobiontida Heterolobosea	
	Cryptomonadida Diplomonadida Euglenozoa Hemimastigophora Oxymonada Parabasalia Pedinophyceae Prasinophyceae Prymnesiida « Retortamonadida »	« »
	Haplospora Plasmodiophora	

8 9.

(. 33).

Protista

(. 32)

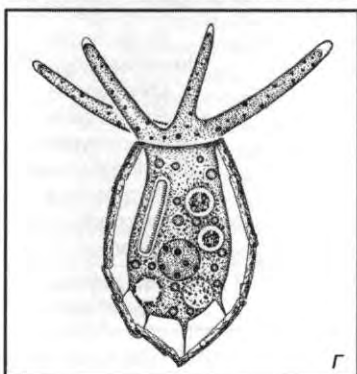
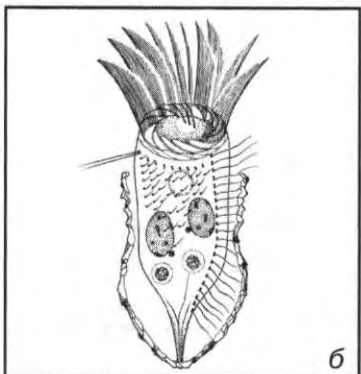
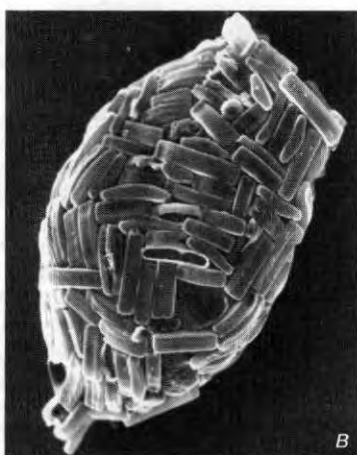
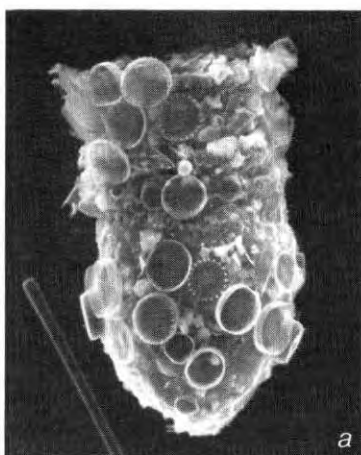

. 32.

— *Codo nella cratera* (); — *Diffugia* () (: Foissner and Hausmann: *Microcosmos* 76 [1987] 258). : a 1 400x, — 700x, — 400x, — 200x.

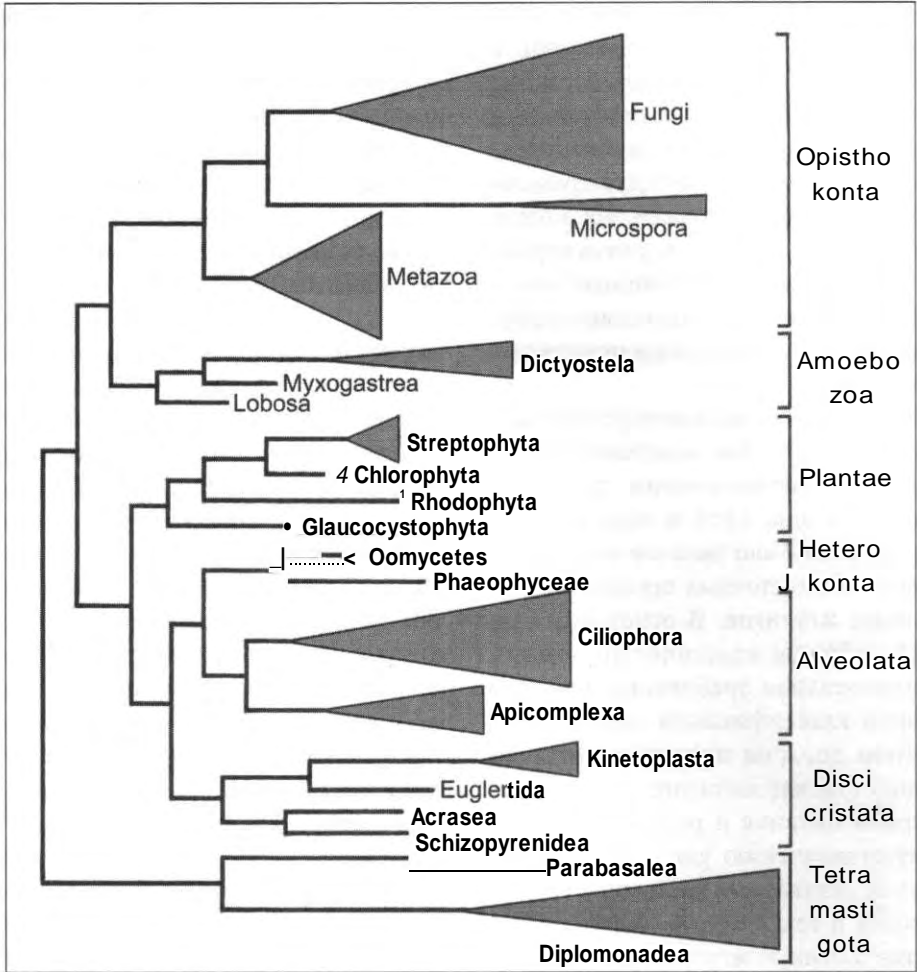

33.

1,

3

(.) .

(distance matrix),

(maximum parsimony)

(maximum

likelihood)

Protoctista

Protozoa,

1910

« »,

(
« » « »

)

1 (

(9x2+ 2)

Flagellata Coën, 1853 Mastigophora
Diesing, 1866

Mastigota.

Masti-

- gophora Flagellata,

()

Phytoma

stigophorea

. Zoomastigo

phorea —

Sarcodina Rhizopoda

1 « »

() .

« » , « » , « » , « »

—

»

EUKARYOTA Chatton,
1925 (Eucarya) —

Eukaryota

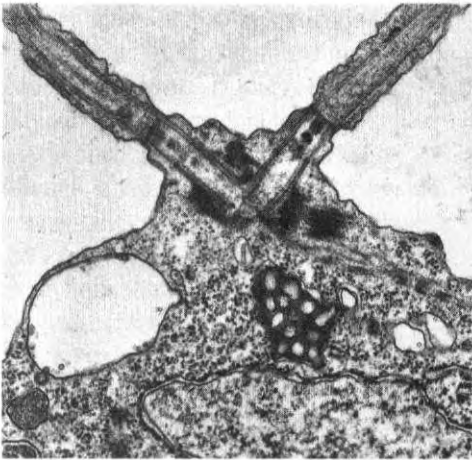

34.

(. 34).

Diphyllia
rotans (= *Aulacomonas submarine*),

(: Brugerolle and Patterson: Europ.
J. Protistol. 25 [1990] 191). : 20 000x.



Рис. 35. Особенности организации свободной части жгутика у хлорофитов (а), хризомонад (б), эвгленовых (в), динофлагеллат (г) и прازیномонад (д).



36. ; — Euglenida, ; — Chrysoomonada, ; — Cryptomonada, ; — Prymnesiomonada (= Haptomonada), ; — Dinoflagellata ; Labyrinthulea, () ;

(. 35), (,) ; (. 34), (. 36), () ; *Chlorarachnion*, Cercozoa, (Conosa), « » ; (1990). —

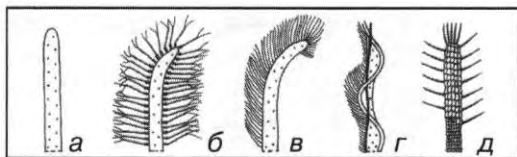
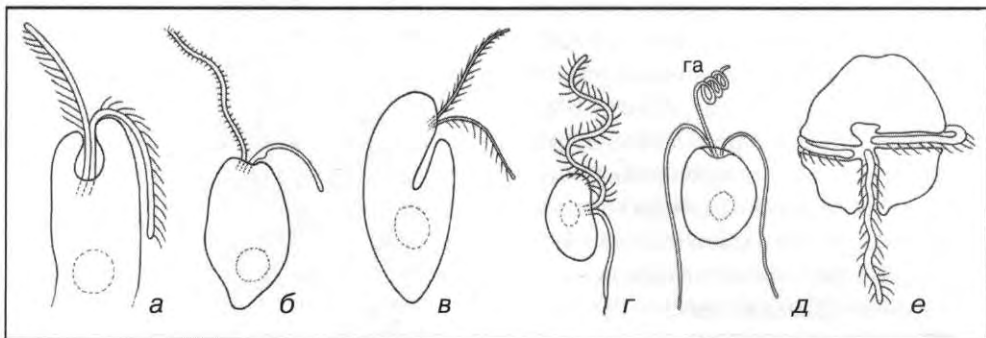
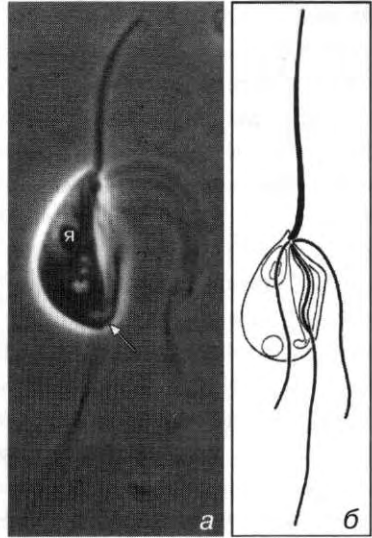

37. Tetramastigota. — *Trimastix marina*,

Eubacteria,

(. . . 328).

TETRAMASTIGOTA Hülsmann & Hausmann, 1994

mastigota,

Tetra

mastigota

(. . . 37).

Tetra

Excavata —

1 —

() ;

)

(

(. excavate —).

Heterolobosa Excavata (. 38).

(Retortamo

{Jakoba, Histiona, nas); Chilomastix —

Reclinomonas),

Trimastix, Carpediemonas

Malawimonas.

Excavata

Excavata,

Euglenozoa

Tetra

mastigota

Heterolobosa.

()

RETORTAMONADEA Grassé,
1952 —

(5 20)

{Chilomastix mesnili

, Chilomastix gallinarum

).

: Chilomastix, Retortamonas.

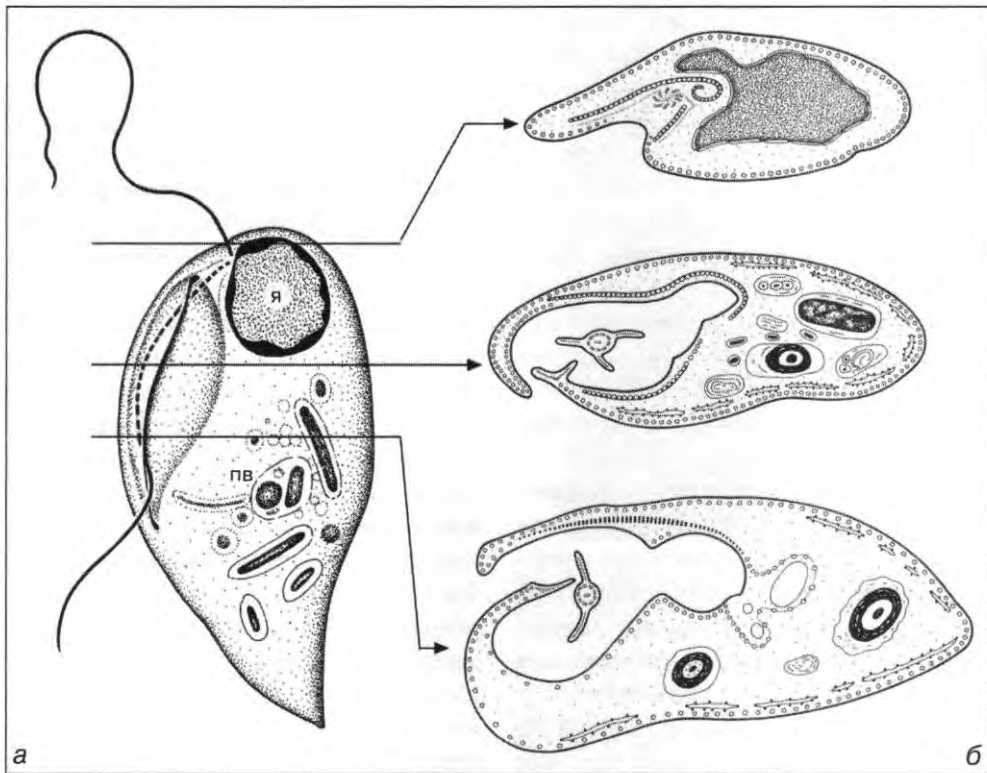

38. Tetramastigota, Retortamonadea: *Retortamonas*, ()

() . : - 7 , - 15

DIPLOMONADEA Wenyon,
1926 —

: Enteromona
dida Diplomonadida.

Enteromonadida Brugerolle,
1975 —

Enteromonadida

15

, *Enteromonas hominis*)

: *Caviomonas*, *Enteromonas*, *Trimitus*.

Diplomonadida Wenyon,

1926 —

Diplomonadea,

39).

Giardia (= *Lamb*

39)

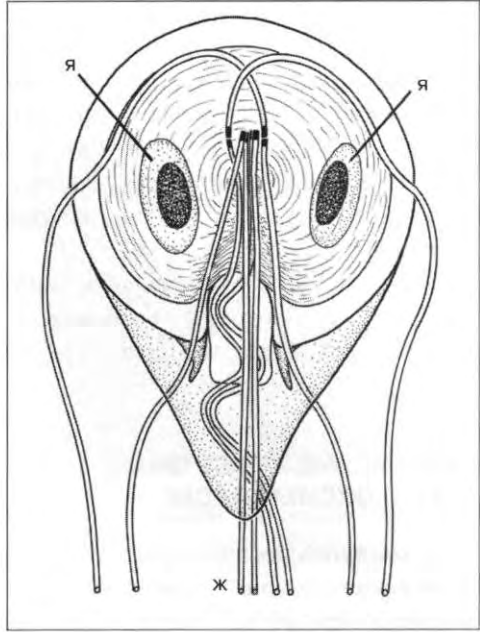

. 39. Diplomonadea: *Giardia* (= *Lamblia*)

() () . : 6 ()

100

.),
Giardia

50

: *Hexamita*, *Trepomonas*,
Trigonomonas; : *Giardia*,
Octomitus, *Spironucleus*.

« ... ». Polymastigi-
 dae

4

OXYMONADEA Grasse,

1952

Oxymona-

didae

Oxymonadidae

Pyrrsonymphidae

40).

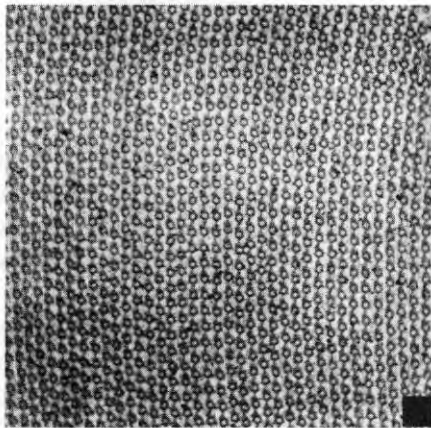
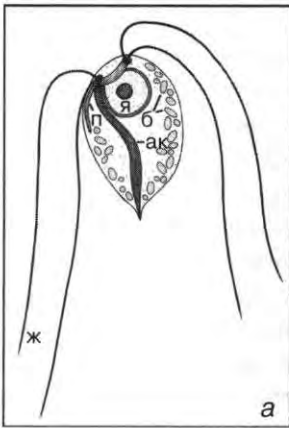

40. Oxymonadea: — *Monocercomonoides hausmanni* (), —
 (), (), (). —
 (— : Radek: Arch. Protis
 tenk. 144 [1994] 373; —
 2 , 6 — 32

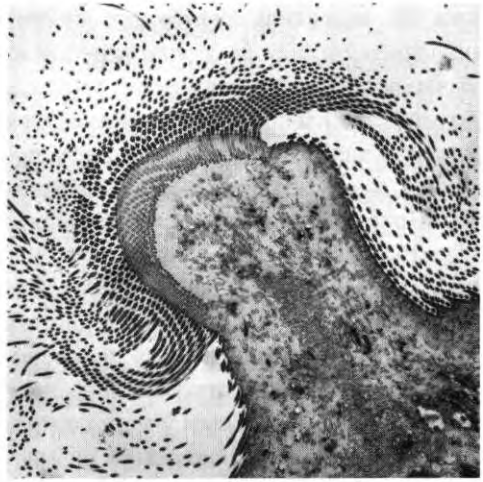

41. Parabasalea: *bonita*. : 1 800 .

Parabasalea

(. . .),

(. 41, 44).

(. . .),

monas ivm).

: *Monocercomonoides*,
monas, *Pyrrsonympha*, *Saccinobaculus*.

PARABASALEA Honigberg,
1973 —

(20 30)

Parabasalea —

Parabasalea —

Parabasalea

Trichomonadida Kirby,

1947 —

5 25

4 6

Trichomonadidae

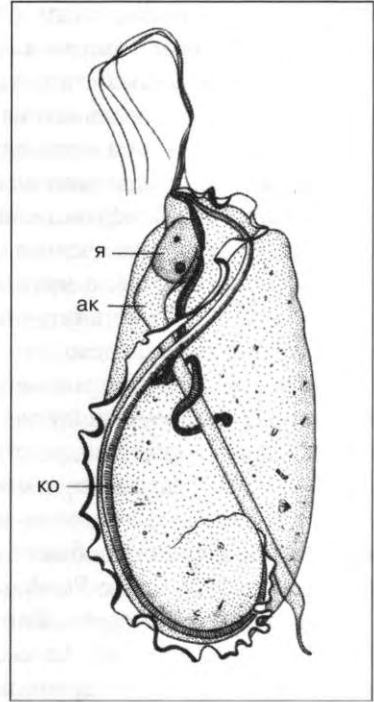

42. Trichomonadida: *Trichomitopsis*
(= *Trichomonas*) *termopsidis*.

3 500

nas,

; *Dientamoeba,*

(*Histomo*

).

(. 24 , 42).

-

Cochlosomatidae

Trichomonadida.

(),

Cochlosoma

monadida

Tricho-

Trichomonas

: *Dientamoeba* (

nalis

: *Trichomonas vagi-*

), *Monocercomonas* (3+1),

hominis,

Mycoplasma

Pentatrachomonas (5+1), *Tritri-*

chomonas (3+1), *Calonympha*

Coronympha ().

Hypermastigida Grassi &

Foa, 1911 —

hominis

; *foetus*

Mixotricha paradoxa,

(. 43, 44).

Calonymphidae

(),

().

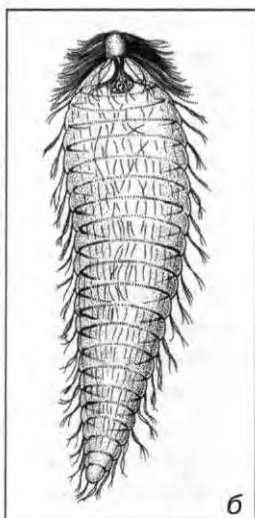
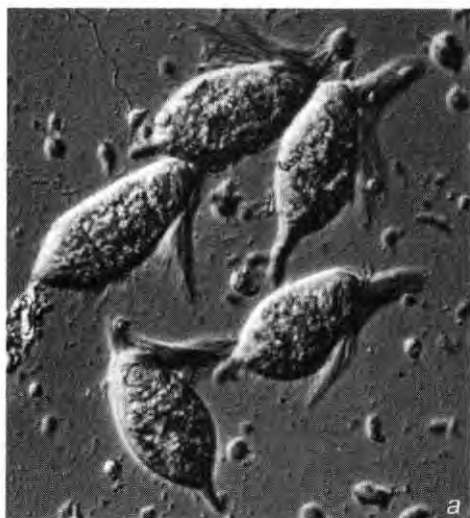

43. *Hypermastigida*: — (*Joenia annectens*)

Kalotermes flavicollis,
 — *Teratonympha mirabilis* ().
 : — 200 , — 280 .

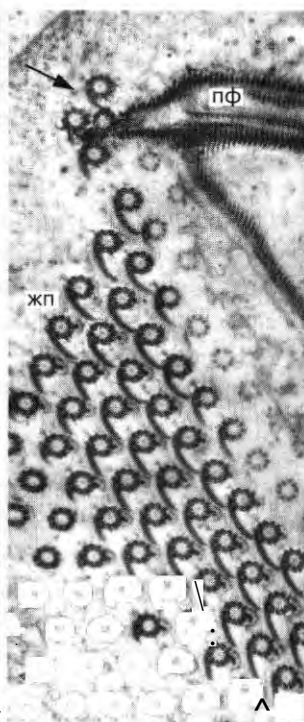
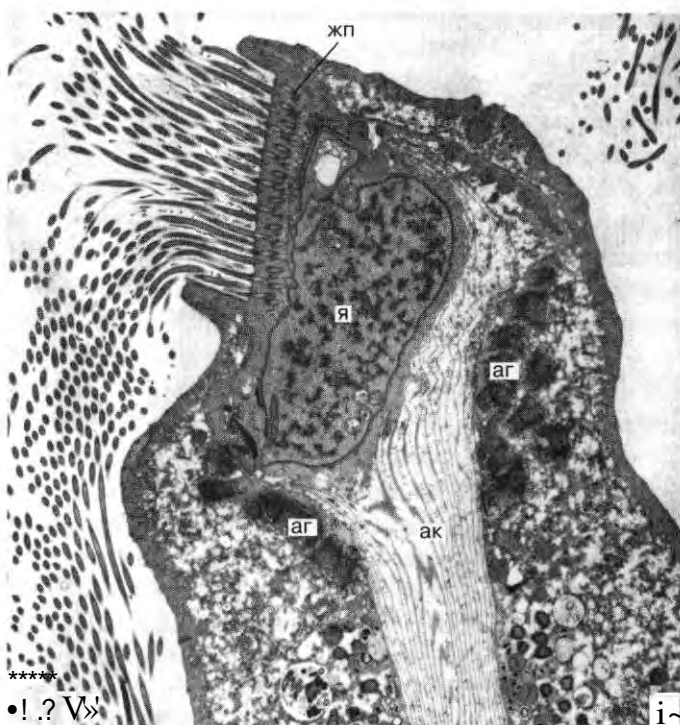

44. *Hypermastigida*: — *Joenia annectens* (), (), () *J. annectens* (). — () . — (— : Radek and Hausmann: BIUZ 21 [1991] 160). : a — 3 , 6—13 .

(
Cryptocercus),

Devescovichidae,

Hypermastigida

: Eucomonymphidae, Trichonymphidae Spirotrichonymphidae + Holomastigotidae.

, a Spirotrichonymphidae Holomastigotidae

: *Barbulanympha*, *Joenia*, *Lophomonas*.

DISCICRISTATA Cavalier
Smith, 1998

: Euglenozoa Heterolobosa.

EUGLENOZOA Cavalier
Smith, 1981

Euglenozoa

. 246, 45);

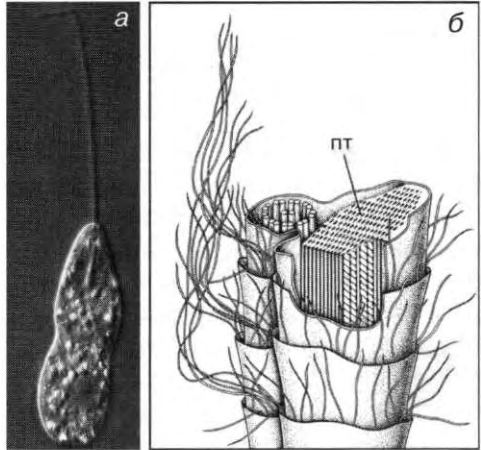

. 45. Discicristata, Euglenida: —

Anisonema. —
(—). .: — 500 , —
40

nozoa, , Egle
 () .

1,2

0,2

Euglenida,

Kinetoplasta.

— Eugleni-

da Kinetoplasta — Euglenozoa

:

Postgaardi.

()

Hemimastigophora, *Stephanopogon*

Bordnamonas

Euglenozoa.

EUGLENIDA Butschli,

1884 —

1000

те симбиоза гетеротрофной эвг-

1

2

Euglenida

3

Euglenozoa. —

Euglenida

« » « » . — . . .

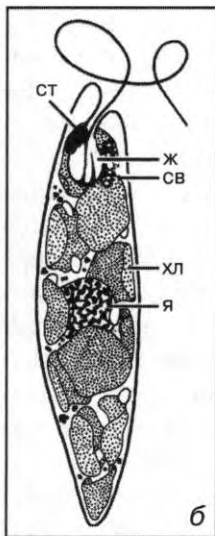
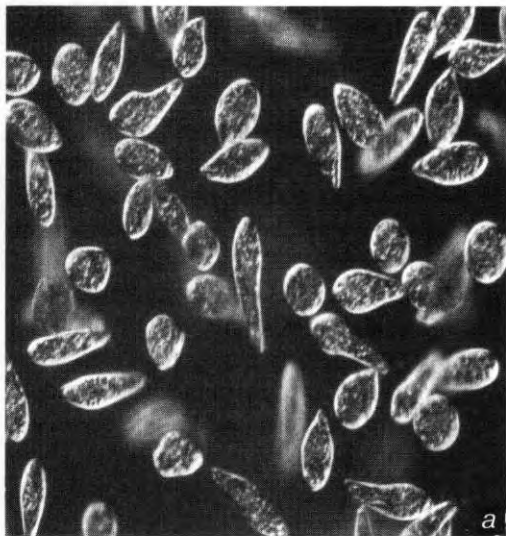

46. Euglenida:

Euglena gracilis,
Euglena gracilis,
 — 1 200 .

« »

(, *Phacus*)

(*Trachelomonas*)

(*Colacium*).

()

(,),

()

(2 20).

Chlorophyta. : *Anisonema*, *Astasia*, *Entosiphon*,

KINETOPLASTA Honigberg,

1963

(800)

(. 47),

Euglenida

(. 48).

« »

Astasia.
Euglenida

(Neusiedl,
).

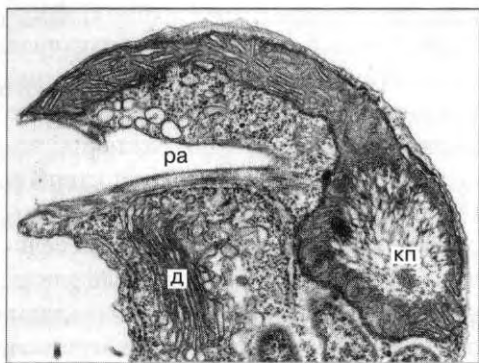

. 47. Kinetoplasta, Bodonea:
Bodo ()

: *Euglena*,

Eutreptia, *Phacus*;

: 7 200 .

50).
 (. 49,
 :
 20 38 . . .) 25 50,
 (5000 27000, 0,46
 2,5 . . .).

(. guide RNA),

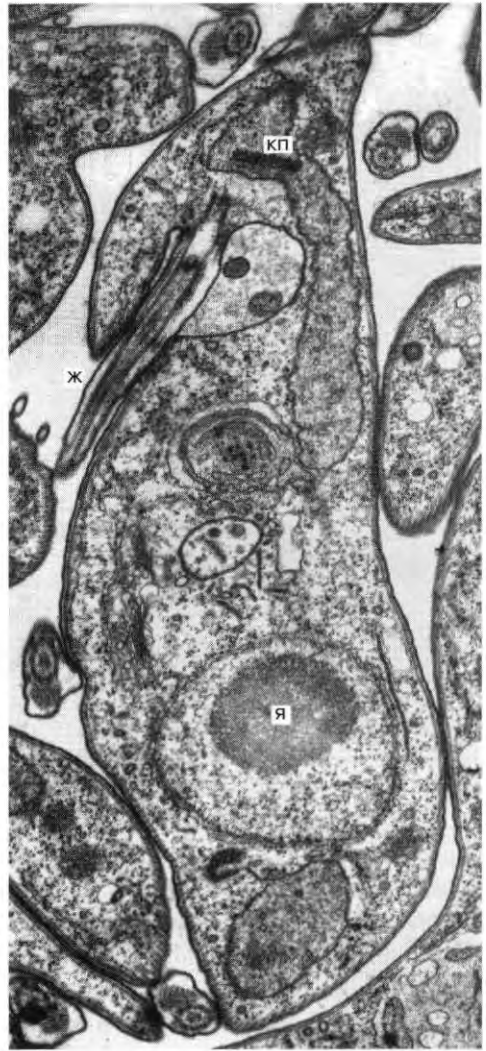

. 48. Kinetoplasta, Trypanosomatidea:
Trypanosoma brucei

(. . .) . . . : 20 . . .

(. . .) . . . (. . .) . . .

; . . . ;

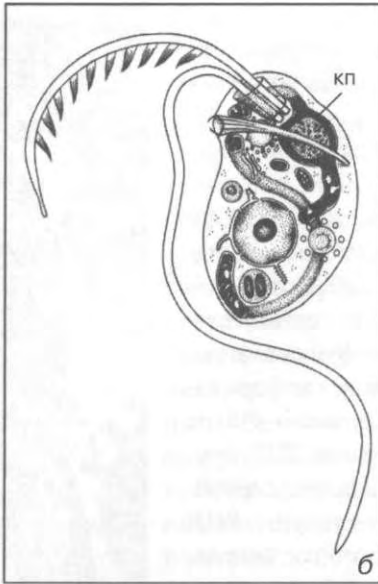
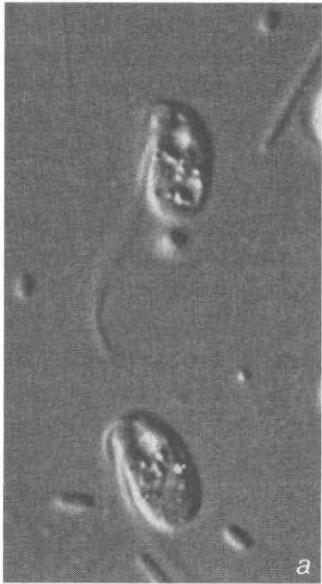

49. Bodonea: -
 Bodo ()
 (), —
 (—) .
 : — 1 , —
 2 200 .

Bodonea

(. 49).

18S

1

2

2

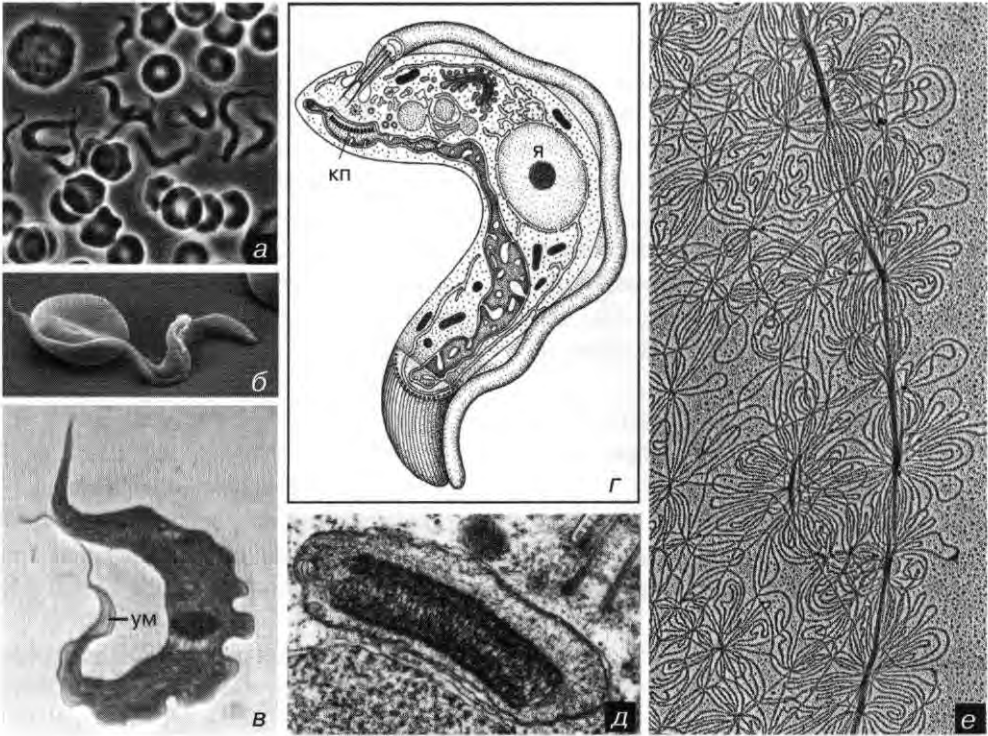

50. Trypanosomatidea: *Trypanosoma brucei* (—);
fallisi; — *congolense*; —
Blastocrithidia triatomae; — *Crithidia fasciculata*. —
 ; — (—)
 ; — : Martin and Desser: J. Protozool. 37 [1990] 199); —
 ; — : Perez Morga
 and Englund: J. Cell Biol. 123 [1993] 1069). : a 800x, б 2 , — 3 200x, —
 7 200x, — 36 , e — 85 000x.

BODONEA Hollande, 1952 —

(. 49).
 ; — (—) —
 (. 49).
 ; — (—) .

• : (= ;
):
 , *Bodo saltans* ;
 () • (= ;
Rhynchomonas nasuta () :
). - ;
 — - • (= ;
):
 : *Bodo* (;
), *Cryptobia* (), *Ich* • : -
thyobodo (). - ;

TRYPANOSOMATIDEA Kent, 1880 —

• : -
 ;
 — • : -
 (. . 15). - • : -
 , , -
 - -
 , -
 (. 50). , , -
 (,) ; -
 - (. 10). -
 () , -
 — — -
 (. 51). - ,
 (. 51, 52). -
 , -
 • ,
 (=) :

Trypanosoma

Leishmania,

()

			<i>Glossina</i> spp.	
	()		<i>Glossina</i> spp.	
()	()		<i>Glossina</i> spp.	
			<i>Glossina</i> spp.	
			<i>Triatoma</i> <i>Rhodnius</i> spp.	
			<i>Tabanus</i> spp.	
			<i>Tabanus</i> <i>Stomoxys</i> spp.	
			<i>Lutzomyia</i> spp.	
()			<i>Phlebotomus</i> spp.	
			<i>Phlebotomus</i> spp.	

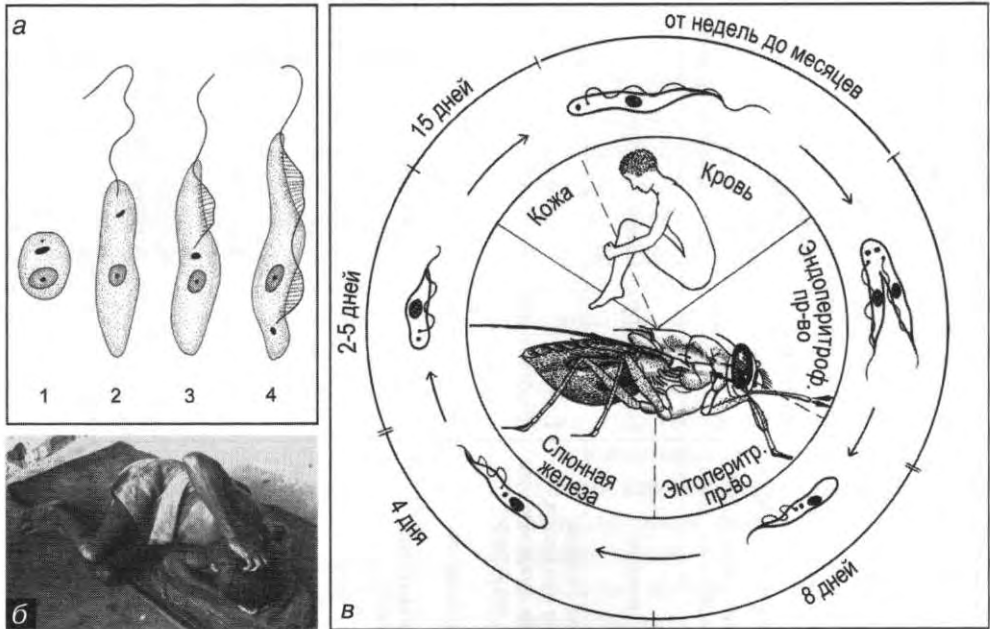

51. Trypanosomatidea. — : 1 — (=), 2 — (=), 3 — (=), 4 — (=); — (—); — (—).
Trypanosoma brucei gambiense.
 WHO TDR Image Library,

Trypanosoma Leish
 mania
 : [Tabanus [Tabanidae —], *Glossina* = [Muscidae —], *Phlebotomus* [Psychodidae —], *Triatoma Rhodnius* [Reduviidae —]), (Desmodontidae).
Trypanosoma brucei (. 51),

. 52. Trypanosomatidea:

Trypanosoma cruzi: 1 —

(), 2 3 —

(2)

(3), 4 —

(), 5 —

Redu

viidae, 6 —

(7),

().

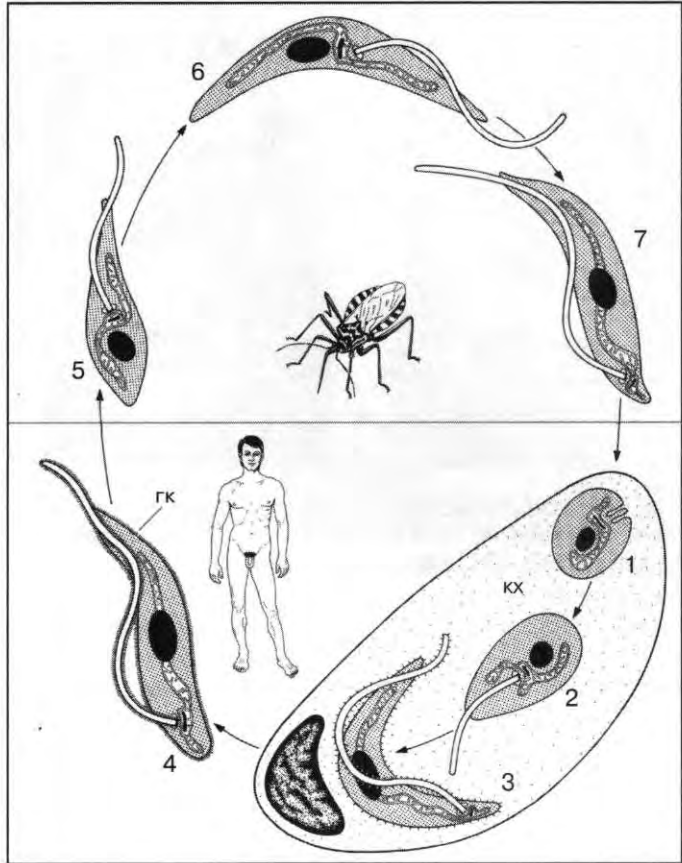



. 53. Trypanosomatidea:

WHO TDR Image Library, () ()

Toxoplasma *Pneumo-*
cystis.

15)

(. 52).

1000)
40%

(. 53).

) *Leishmania donovani*

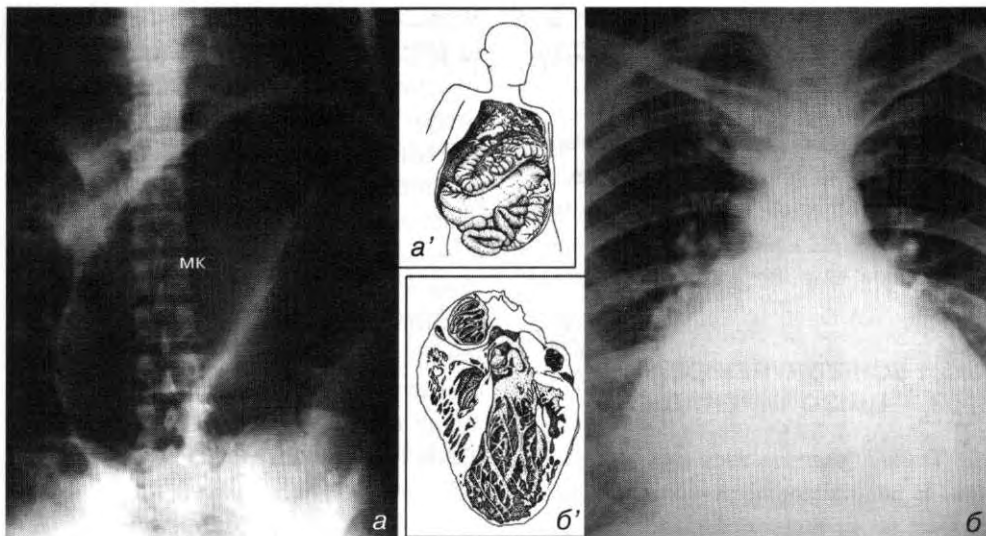

54. Trypanosomatidea:
Trypanosoma cruzi, ' —
 (—) (—
 1990, ' —)

(—); , ' —
 WHO TDR Image Library, Geneva

DIPLONEMIDA Cavalier
 Smith, 1993

Leishmania infantum

2 : *Diplonema* (*Isonema*)
Rhynchopus.

(. 54).
Phytomonas,

700
 500

Trypanosoma.
 : *Leishmania*, *Phytomonas*,
Trypanosoma.

: *Diplonema*, *Rhynchopus*.

HETEROLOBOSA Page & Blanton, 1985 —

Sarcodina, -

(*Tetramitus*)

(. 55).

SCHIZOPYRENIDEA Singh, 1952 —

100 -

Vahlkamfia

Tetramitus,

Naegleria.

{*Naegleria*

fowleri , *Naegleria austriacensis*)

Acrasea.

40 ° (

. 19).

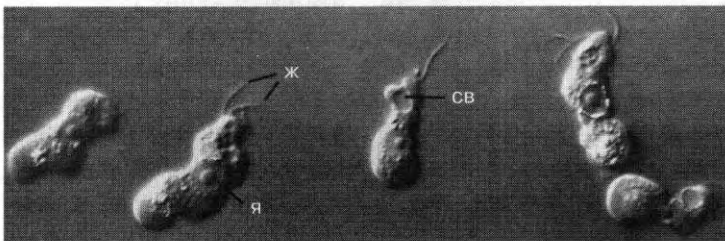

. 55. Heterolobosa, Schizopyrenidea:

Naegleria.

: 1

() .
Naegleria
 : *Naegleria* (
), *Tetramitus* (
), *Vahlkamfia* (
), *Willaertia*.

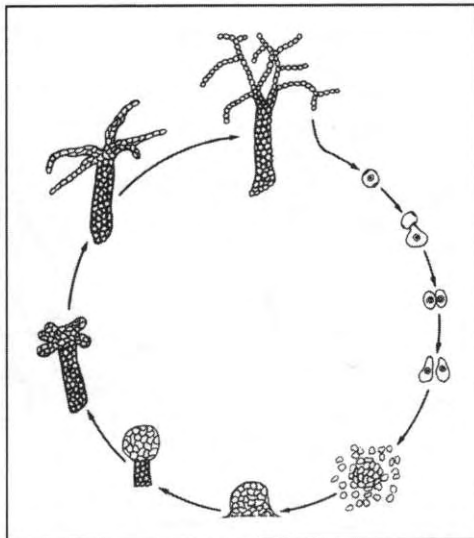

ACRASEA Blanton, 1990 —

. 56. Acrasea: *Acrasis rosea* (: Olive et al.: J. Protozool. 8 [1961] 467).

(. 56). Acrasea
 :
 () .
 : *Acrasis*, *Pocheina*.

*
 (. 576).

HEMIMASTIGOPHORA

Foissner et al., 1988

(. 57).

20
 10 60
 Discicristata
 (. 57).

: *Hemimastix*, *Paramastix*,
Spiroonema, *Stereonema*.

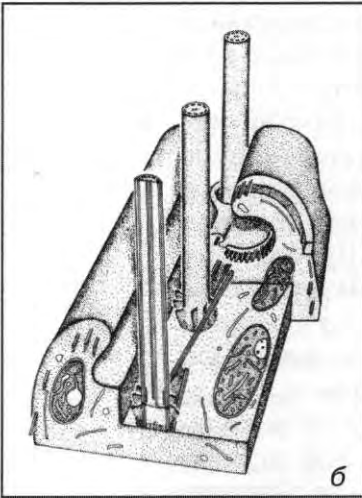
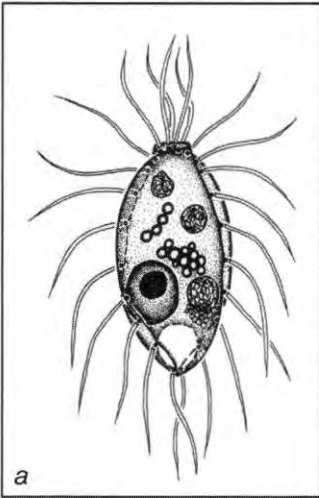

57. Hemimastigophora: — *Hemimastix amphikineta*. —

— . *amphikineta*.
 — . *amphikineta*



(: Foissner et al.: Europ. J. Protistol. 23 [1988] 361).
 a — 2 200x.

PSEUDOCILIATA Corliss & Lipscomb, 1985

Stephanopogon

Ciliophora.
apogon

Stephanopogon

Stephanopogon (. 58).

(Primociliata).

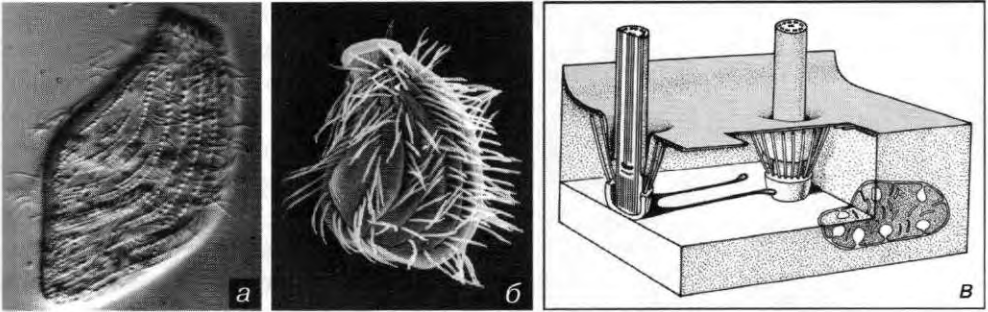

58. Pseudociliata. *Stephanopogon*: (),
 () () (— ; — ; —) ; — 800 , — 8

.]
 ;
 ,
 (. 58).
 2 16) —
 — (20
 50) ,
 100 (. 31).
 : *Stephanopogon*.

CHROMISTA Cavalier Smith,
 1987

PRYMNESIOMONADA
 Hibberd, 1976 (Haptomonada,
 Haptophyta) — 0 0

Hapto-
 phyta Haptomonada,
 [. —

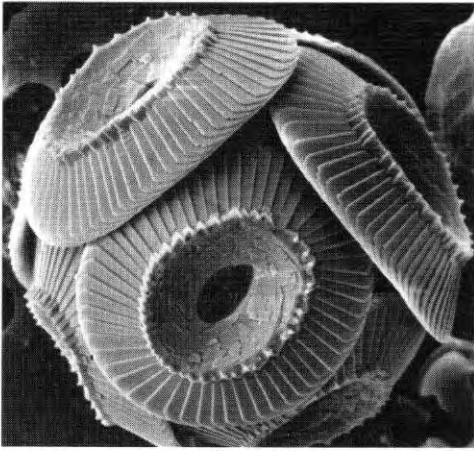

59. Chromista, Prymnesiomonada:

Coccolithus pelagicus (). : 4 300 .

500

(. 59).

()

(. 60).

6 8

(. . 277).

100

(

Phaeocystis

(. . 353).

Chrysochromulina

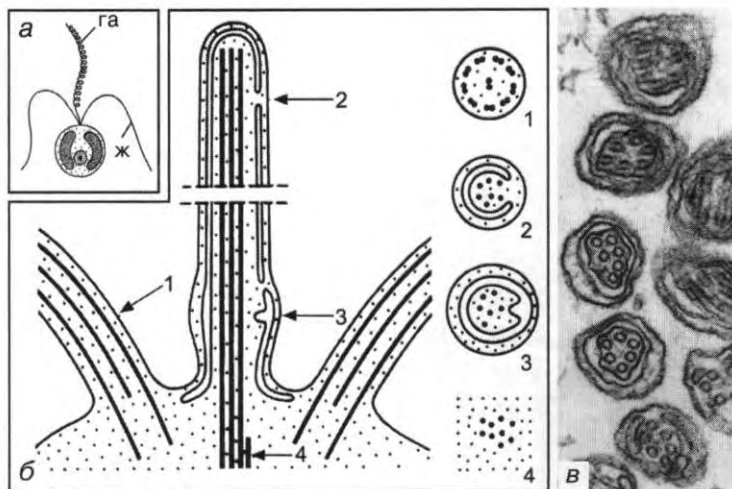

60. Prymnesiomonada: — ()
 (); — : 1 —
 9x2+2; 2 4 —
 (—
). : —65

1988 - ra (, -
 -); *Chrysochromulina*,
 (*Prymnesium* (
 -); *Diacronema*, *Pavlova* (-
 .)

CRYPTOMONADA Senn,

1900 —

1,5

: *Emiliana*, *Pleurochrysis* 61).

(); *Coccolithus*, *Umbellosphae*),

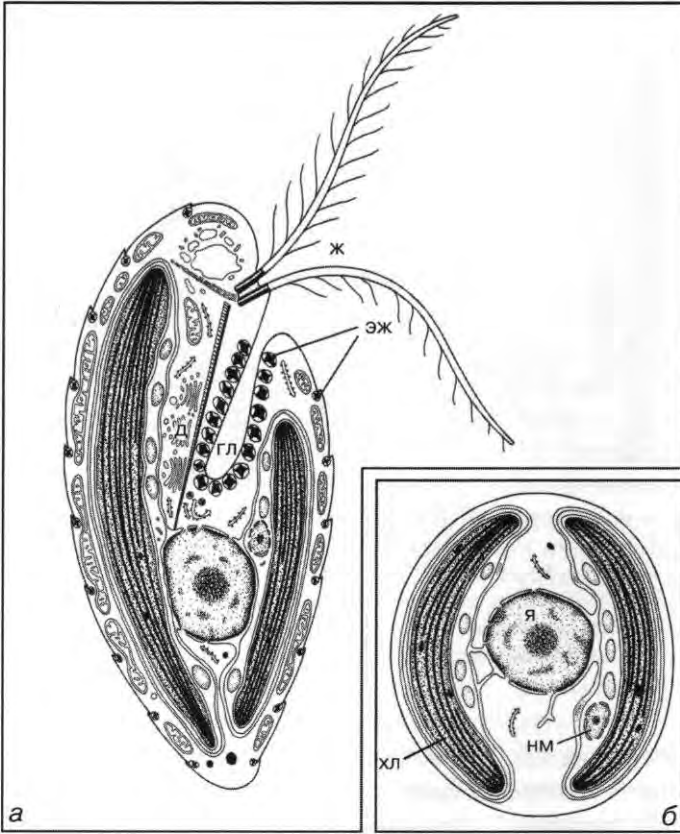

61. Chromista,
 Cryptomonada: -
 () ()
 Cryptomonas
 ovata, -
 *
 () () . —
 — , —
 — , —
 (—
). : 5 500 .

(. . 242).

Chlorophyta Rhodophyta,
1

(. 61).

. 19)

Guillardia theta

551 264

350×10^9

— 121

— 48

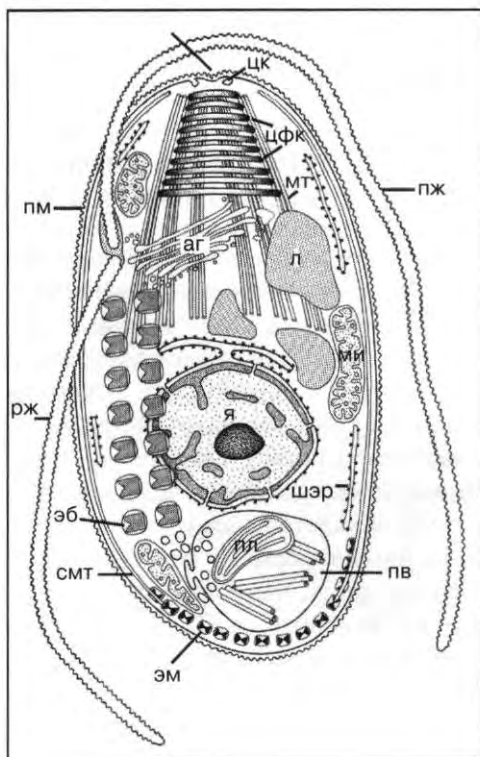

. 62. Cryptomonada:

Katablepharis remigera.

(),

()

().

()

()

(),

().

(),

62, —

(

).

8 500

: *Chilomonas*, *Cryptomonas*,
Guillardia, *Katablepharis*, *Pyrenomonas*,
Rhodomonas.

HETEROKONTA Luther,

(Phaeophyta)

1899

», «
; ,

(— strame
nopiles),

(>
. 254).

(

)

(. 29),

(. 254) (. 249).

();

1;

PROTEROMONADEA Grasse,
1952

10 30

: *Karotomorpha*, *Proteromonas*.

OPALINEA Wenyon, 1926 —

400 4

Opalineia

Proteromonas (. 63)

(3)

(. 64).

()

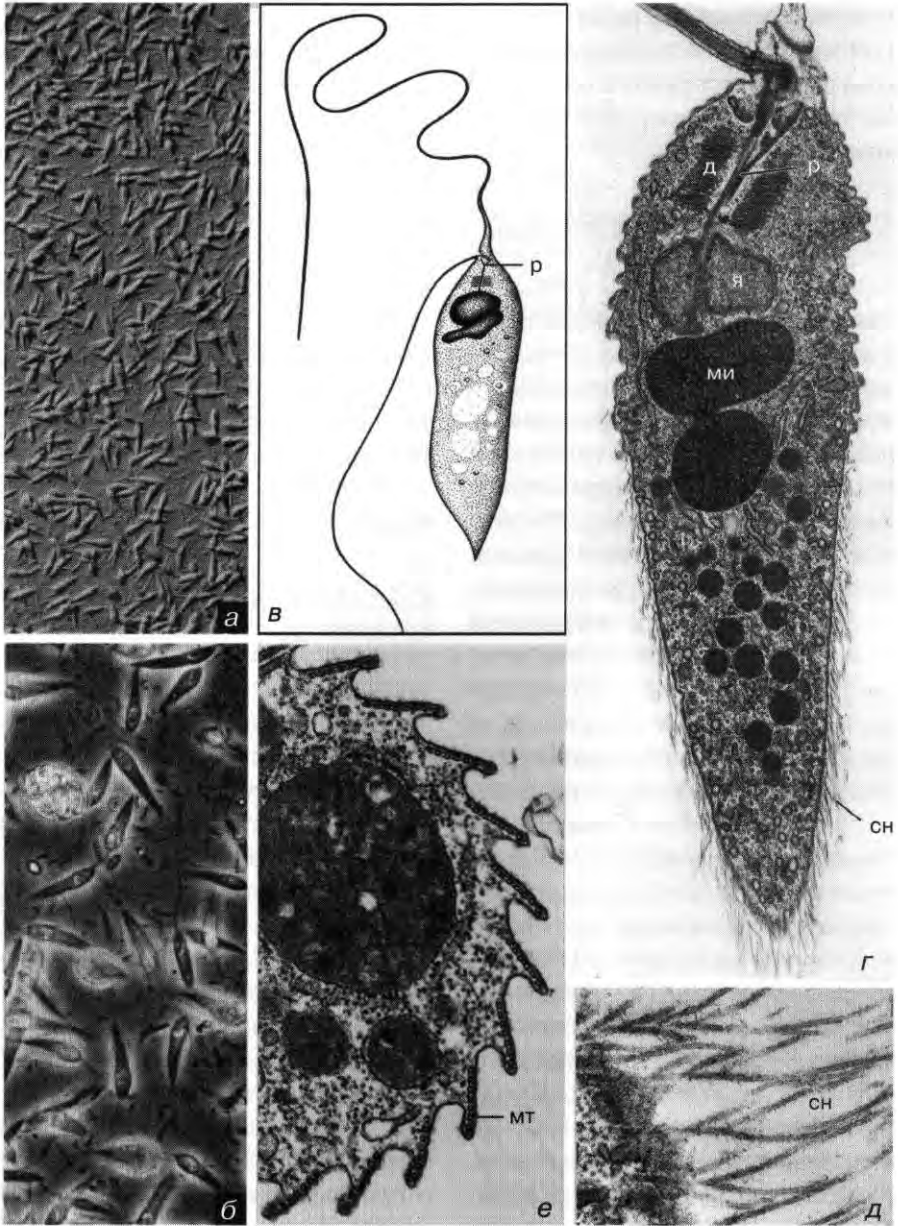

63. Chromista, Heterokonta, Proteromonadea: *Proteromonas lacertae viridis* (): - (,), () (,); - *Karotomorpha bufonis* (). - () - () - 3 500 , - 10 , - 50 , - 40 .) . : - 350 , - 850 ,

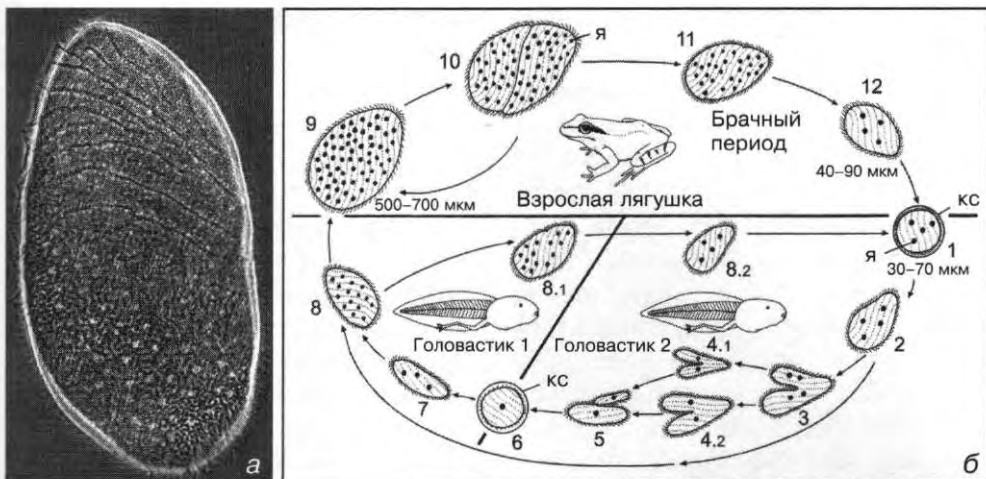

64. Heterokonta, Opalineae: — *Opalina ranarum* ; — -
ranarum: (1); -
(2); (3, 4);
(5); *Opalina* -
(6); (7, 8);
(8.1, 8.2);
(10), () (9);
2 12 (11, 12); (1),
().

Ciliophora,
Opalineae —

(. 646).

() .

()

()

: *Cepedia*, *Opalina*, *Proto*
 (- *opalina*, *Zelleriella*.

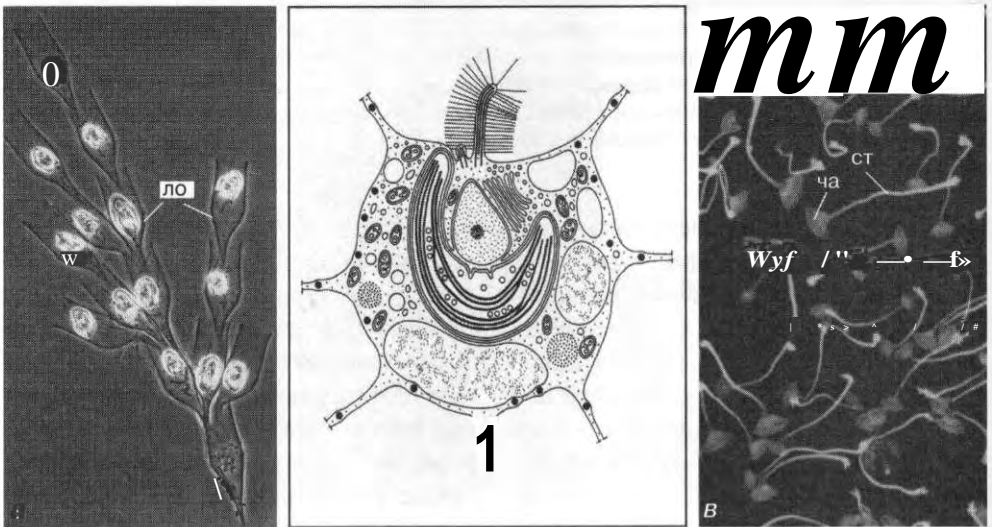

65. Heterokonta, Chrysomonadea: a — *Dinobryon*,
 () ; — *Chrysamoeba radians*
 ; — *Poterioochromonas malhamensis*
 () () — ; —
). : — 450 , 6 — 6 , — 750 .

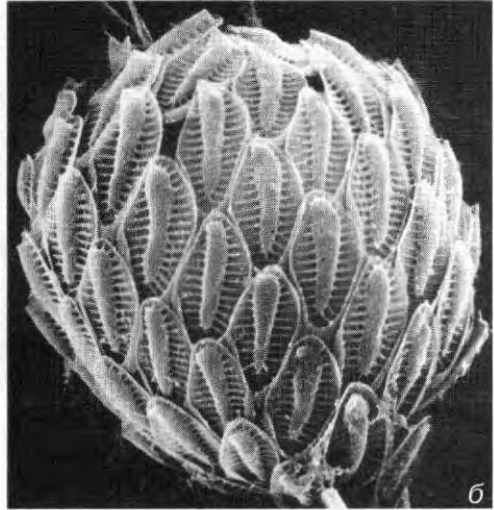
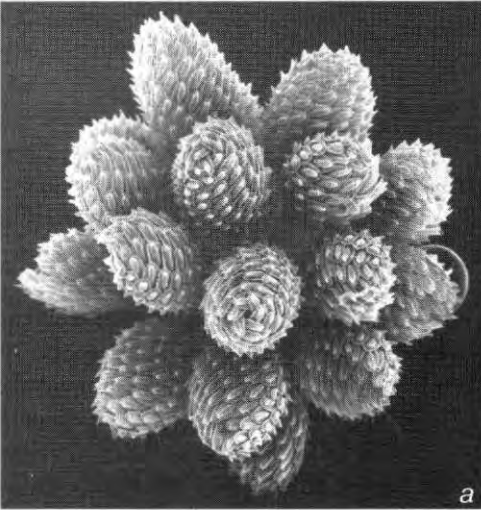

66. Chrysomonadea: (—) Synura petersenii. — ; — — 500 , — 3

CHRYSOMONADEA¹ Engler,

1898 —

1000

5 20 (. 65).

(Synura, Mallomonas, Paraphysomonas)

(. 66).

¹ phyton — Chrysophyta.

phycos — Chrysophyceae

Dinobryon

Dinobryon)

1

Chrysomonadea —

Chrysamoeba,
— *Chry*

sarachnion.

: Chryso

monadida, Pedinellida

Silicoflagellida.

.67. Chrysomonadea:
Anthophysa (:
 Zollfel and Hausmann:
 Microcosmos 76 [1987]
 353). : 230x.

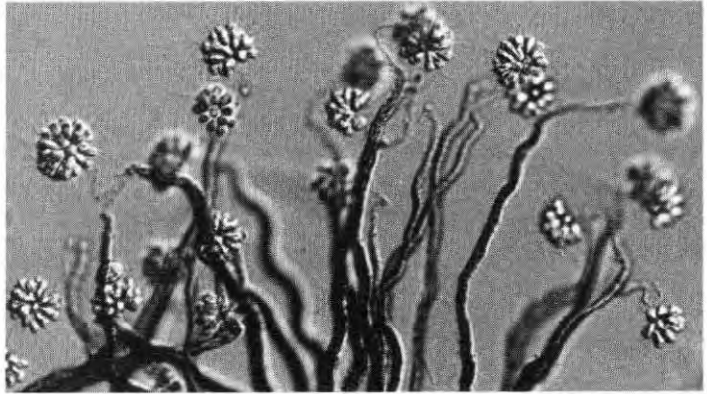

Chrysomonadida Pascher,

1912

3
 : *Oikomonas*, *Pedinella*,
Pteridomonas.

: *Anthophysa*,
Dinobryon, *Ochromonas*, *Synura*;
 : *Chrysamoeba*, *Chrysarachnion*,
Chrysostephanosphaera.

Silicoflagellida Borgert, 1891
 (Dictyochales) —

Pedinellida Pascher, 1910 —

1

2

(, *Pteridomonas*)
 ()

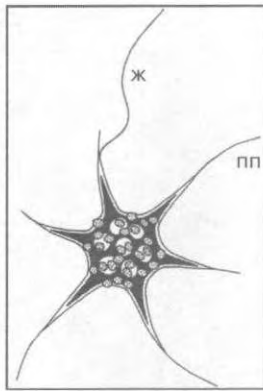
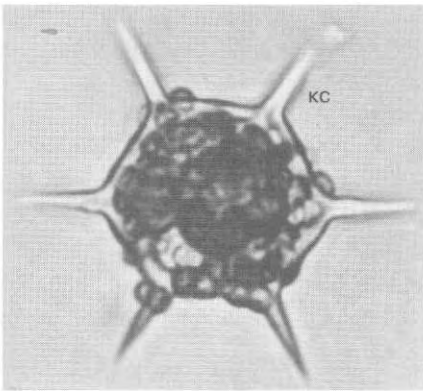

. 68. Chryomonadea, Silicoflagellida: *Distephanus speculum* -
 (), () -
 () () (-
 . : - 400 .

(. 68). -

(. 70).

: *Dictyocha*, *Distephanus*.

BACILLARIOPHYCEAE

Haechel, 1878 (Diatomeae) —

100

(. 69).

. 69. Heterokonta, Bacillariophyceae: — *Tabellaria*, — *Fragilaria*,
 — *Arachnoidiscus*, — : 1 7 — ; 8 10 —
 ; 1 3 — *Pinnularia viridis*, 4 — *Licmophora flabellata*, 5 — *Synedra gracilis*,
 6 — *Asterionella formosa*, 7 — *Tabellaria flocculosa*, 8 — *Coscinodiscus pantocseki*, 9 —
Triceratium distinctum, 10 — *Odontella* (= *Biddulphia*) *aurita*, 11 — *Chaetoceros castracanei*
 (—). : — 200 , — , — 800 , : 1 2 — 500 , 3— 1 ,
 4 6 165 , 7 335 , 8 9 165 , 10 335 , 11 21 .

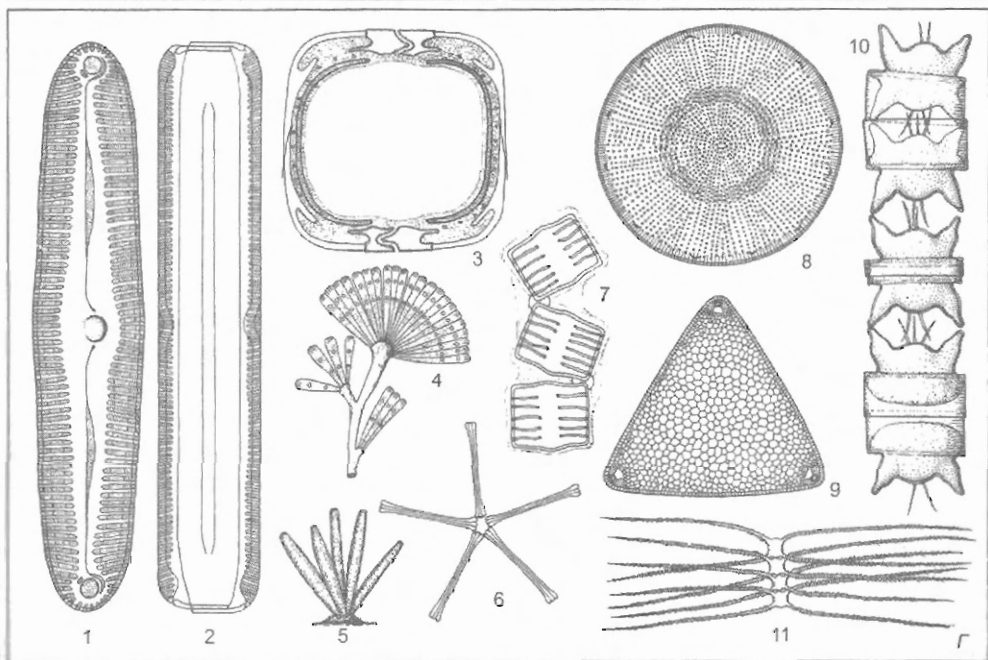
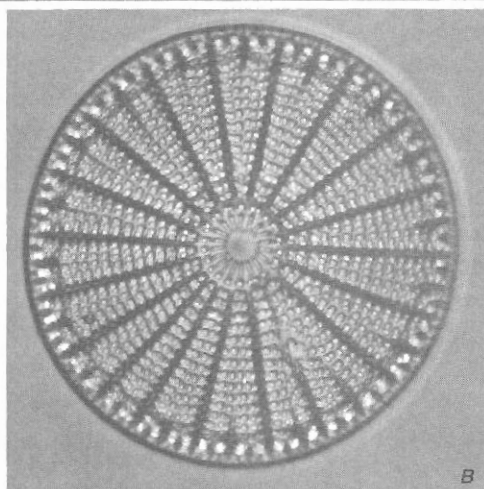
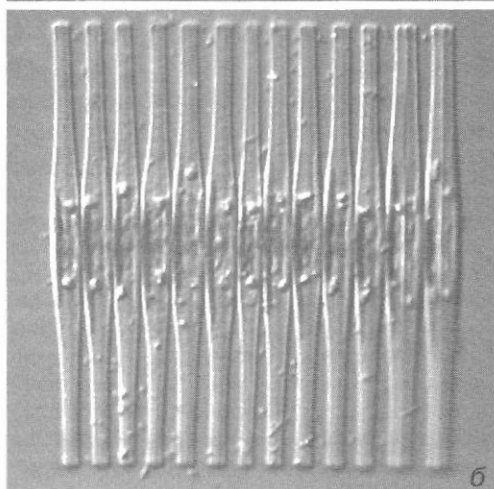
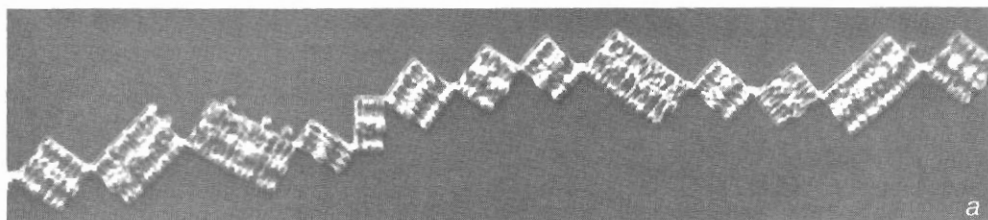

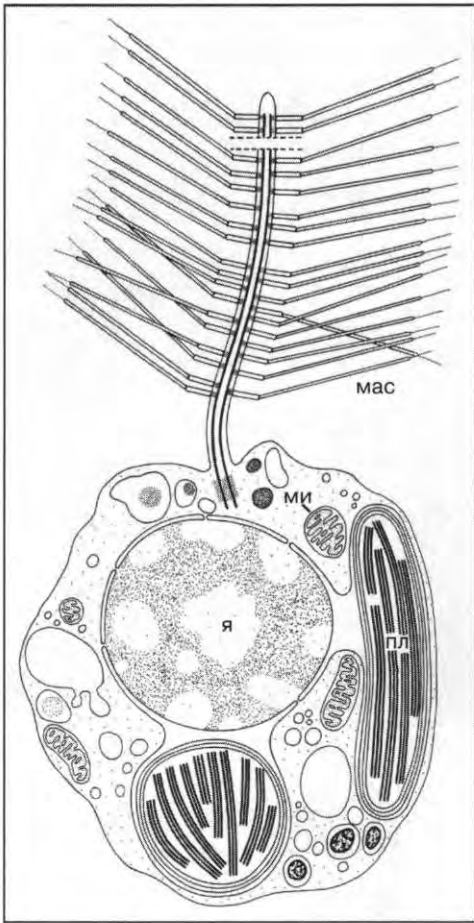

. 70. Bacillariophyceae:

Lithodesmium undullatum

— , —
 — (—)
) . : 7 000 .
 (—)
) .)
 () ,

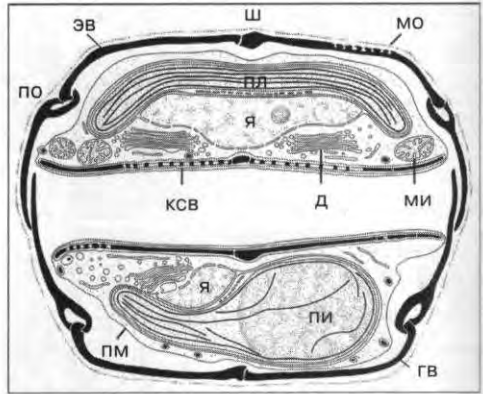

. 71 . Bacillariophyceae:

Amphipleura

pellucida,

— , — , —
 , — , —
 , — (—) .
 : 10 .

), —
 (—)
) .)
 (—)
 (—)
 (—)
 (—)
 : (—)
 (—)
) , (—)
) .

()

()

)

(

)

1

Pseudo nitzschia (*P. multiseriata*,
P. australis, *P. pseudodelicatissima*, *P. pun-
gens* *P. seriata*)

SiO₂),

Thalassio

sira Chaetoceros convolutes,

()
)

(,)

Symbiodinium

nales. : Centrales , Centrales,

: *Bacillaria*, *Navicula*, *Nitzschia*, *Pleurosigma*, *Pseudo nitzschia*.

HETEROMONADEA Leedale, 1983 (Xanthophyceae) —

(.70).

: *Biddulphia*, *Coscinodiscus*, *Odontella*, *Rhizosolenia*.

(3

(*Tribonema*, *Vaucheria*)

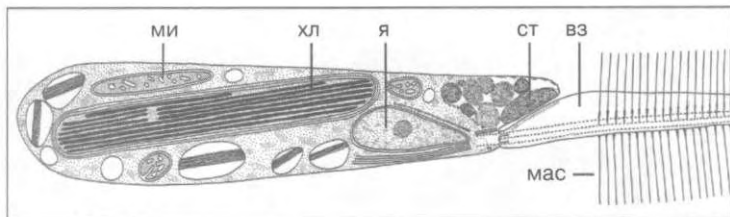

72. Heterokonta, Eustigmatophyceae:

() . : 4 400 .

(. 72),

()¹.

: *Chloromonas*;
: *Chlamydomonas*,
Rhizochloris, *Reticulosphaera*.

: *Eustigmatos*, *Chlorobotrys*,

Monodopsis.

EUSTIGMATOPHYCEAE

Hibberd & Leedale, 1971 —

E

LABYRINTHULEA Cienkowski,
1867 (Labyrinthulomycota) —

6 15

Labyrinthulida

Labyrinthulidae Thraustochytriidae,

40

(10 15)

(. — .)

(. 72).

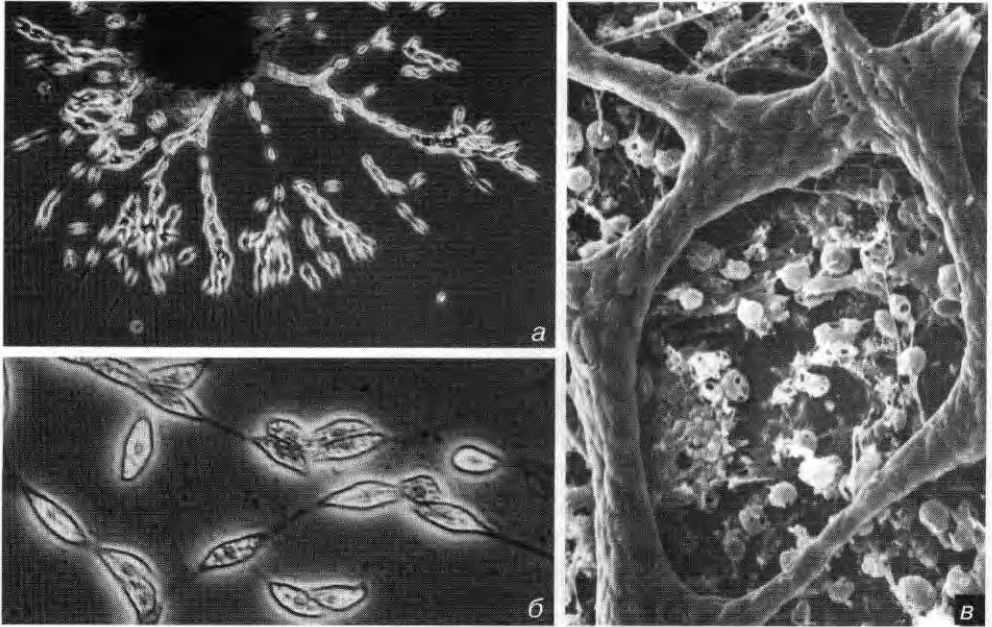

73. Heterokonta, Labyrinthulea: — *Labyrinthula coenocystis*; —
 Mikrosk. Anat. 102 [1969] 387). : a — 190x, — 800x, s — 330x. (— : Stey: Zellforsch.

: *Labyrinthula zosterae*
L. macrocystis —

Laby-
rinthula

(. 73).

(« »)

« »

(. 74).

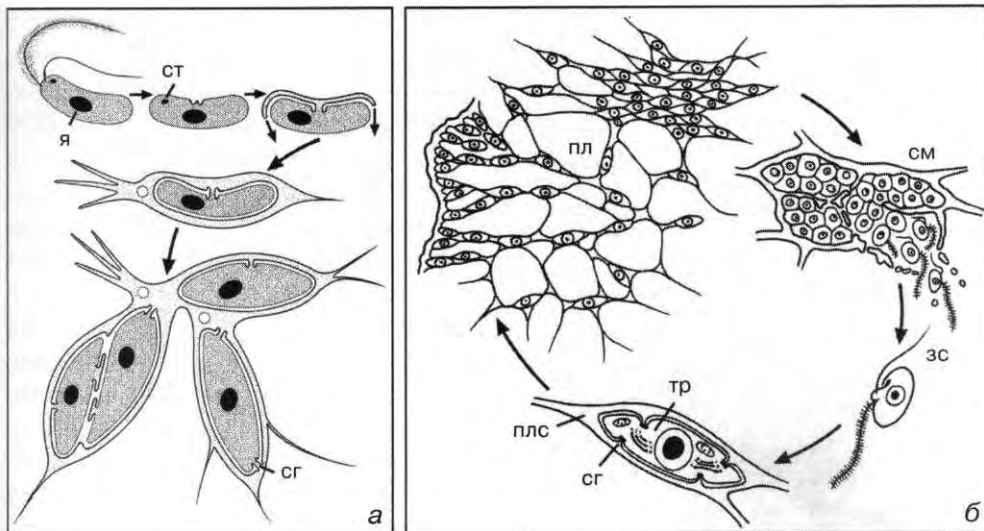

. 74. Labyrinthulea: —

(= « »).

Labyrinthula:

(),

« »

(),

(),

(),

(),

().

Heterokonta.

: *Labyrinthula*, *Labyrithuloides*, *Thraustochytrium*.

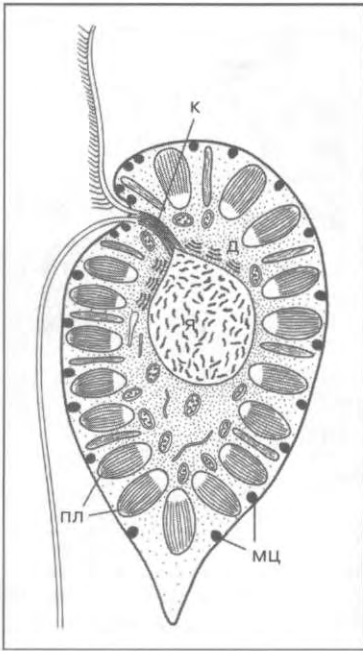

. 75. Heterokonta, Raphidomonadea: *Chattonella* sp.

Vacuolaria.

()
 (), — ()
 ∴ 3 700 .

(Cercozoa).

RAPHIDOMONADEA

(Chloromonadea) Heywood & Leedale, 1983 —

(20) —

(. 75).

Heterosigma
shiwo, *Chattonella antiqua*, *Ch. marina*,
Fibrocapsa japonica

90



Рис. 76. Heterokonta, Bicosoecidea: живые особи (а) и препарат отдельного домика (б) *Bicosoeca* (= *Bicoeca*). (а — любезно предоставлен Х. Шнайдер, Ландау). Увел.: а — 800х, б — 2 400х.

: *Chattonella*, *Heterosigma*,
Gonyostomum, *Fibrocapsa*, *Vacuolaria*.

**BICOSOECIDEA Grasse &
 Deflandre, 1952 —**

40

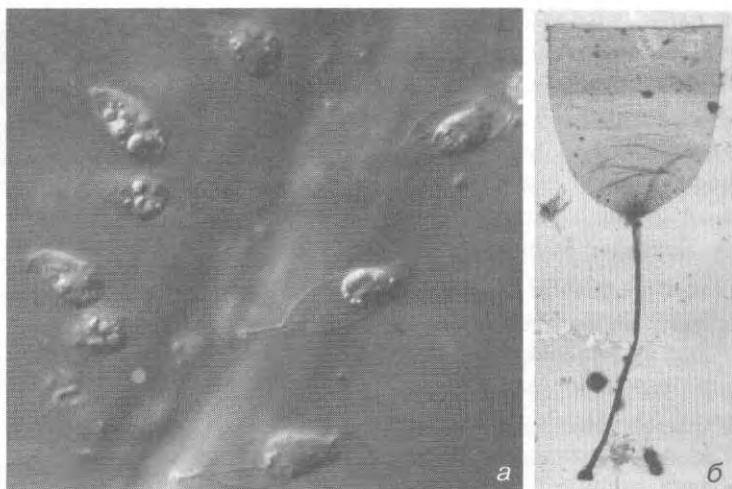
(. 76, 273).

5

, 1 (

2

: *Bicosoeca* (= *Bicoeca*),
Cafeteria, *Pseudobodo*.

60

12

HYPHOCHYTRIOMYCETES

Patterson, 1982 —

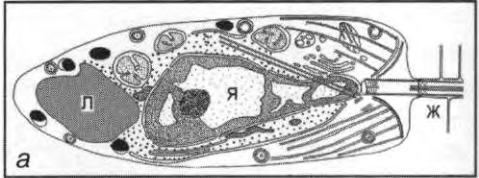

25

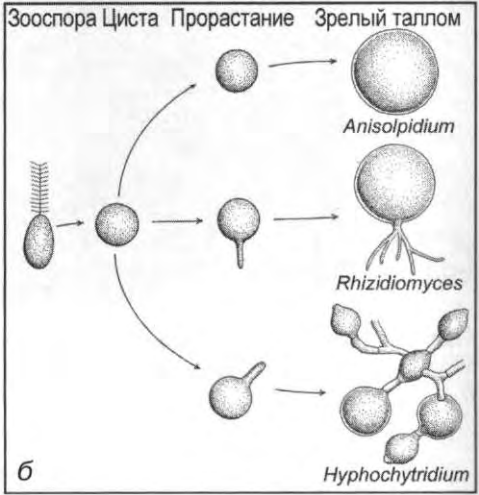

. 77. Heterokonta, Hyphochytriomycetes:

Hyphochytrium ()

(), —

4 6 (. 77)

(—)

∴ — 5

Heterokonta,

Rhizidiomyces.

776,

Hyphochytrium.

18 48

: *Anisopidium*, *Hyphochyt*
rium, *Rhizidiomyces*.

: *Phyto*

OOMYCETES Dick, 1976 —

phthora infestans —

800

65

(The Great Irish Potato Famine),

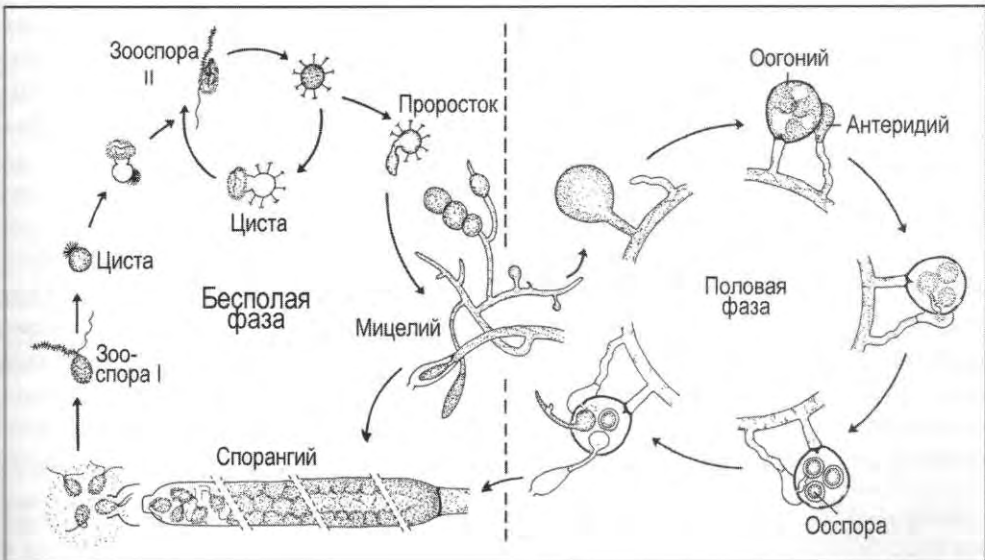

78. Heterokonta, Oomycetes:

Saprolegnia;

Oomycetes

(I)

(II)

()

()

()

()

1840 ¹; *Pythium* spp.,

; *Plasmopara viticola* —

; *Saprolegnia* spp.

Achlya spp., ²

(. . 238).

Saprolegnia)

(. . 78).

¹ 1840

¹ 1845 1852 . — ()

« » . « »

(. .) —

11.

Alveolata

()

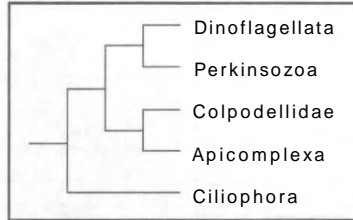

(3 1,3

(3 1,6

(Perkinsozoa

Colpodellidae)

(. 11).

Apicom-

plexa —

: *Achlya*, *Albugo*, *Haptoglossa*, *Plasmopara*, *Phytophthora*, *Pythium*, *Saprolegnia*.

1200

ALVEOLATA Cavalier Smith, 1992 —

Perkinsus;

— Ciliophora, Apicomplexa Dinoflagellata, Ascetospora (Haplospora)

Apicomplexa (. 79).

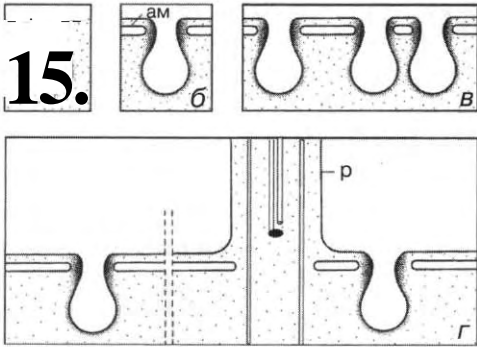

15.
 .79.
 — Perkinsus; Alveolata:
 Apicomplexa; —
 ()
 () —
 — () .

80).
 ()

, Perkinsozoa *Colpodella*.
 ;
 , Perkin-
 sozoa
 , a Colpodellidae —
 Apicomplexa.

DINOFLAGELLATA Biitschli,
 1885 (Dinozoa, Dinophyta) —

2500

4000

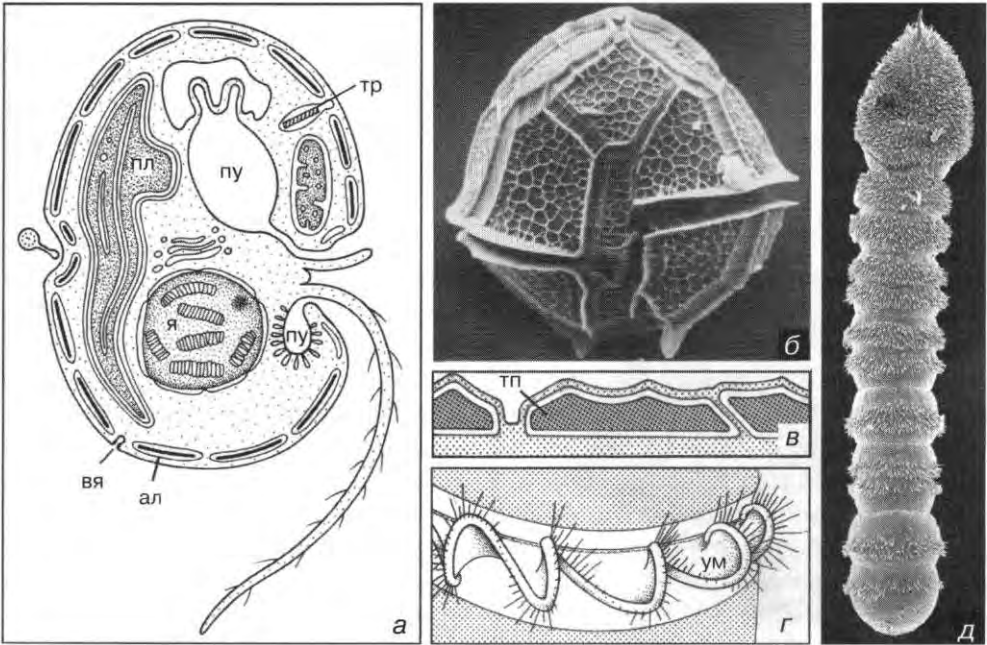

80. Alveolata, Dinoflagellata: — ; —
Pehdinium bipes; — () ; —
 () ; —
 () ; —
Haplozoon axiothellae. — ; — ; —
 — ; — (— ; —
 P.M. ; — : Leander et al.:
 Europ. J. Protistol. 38 [2002] 287). : 6 — 1 000x, —800x.

(. 80)

(. 81).

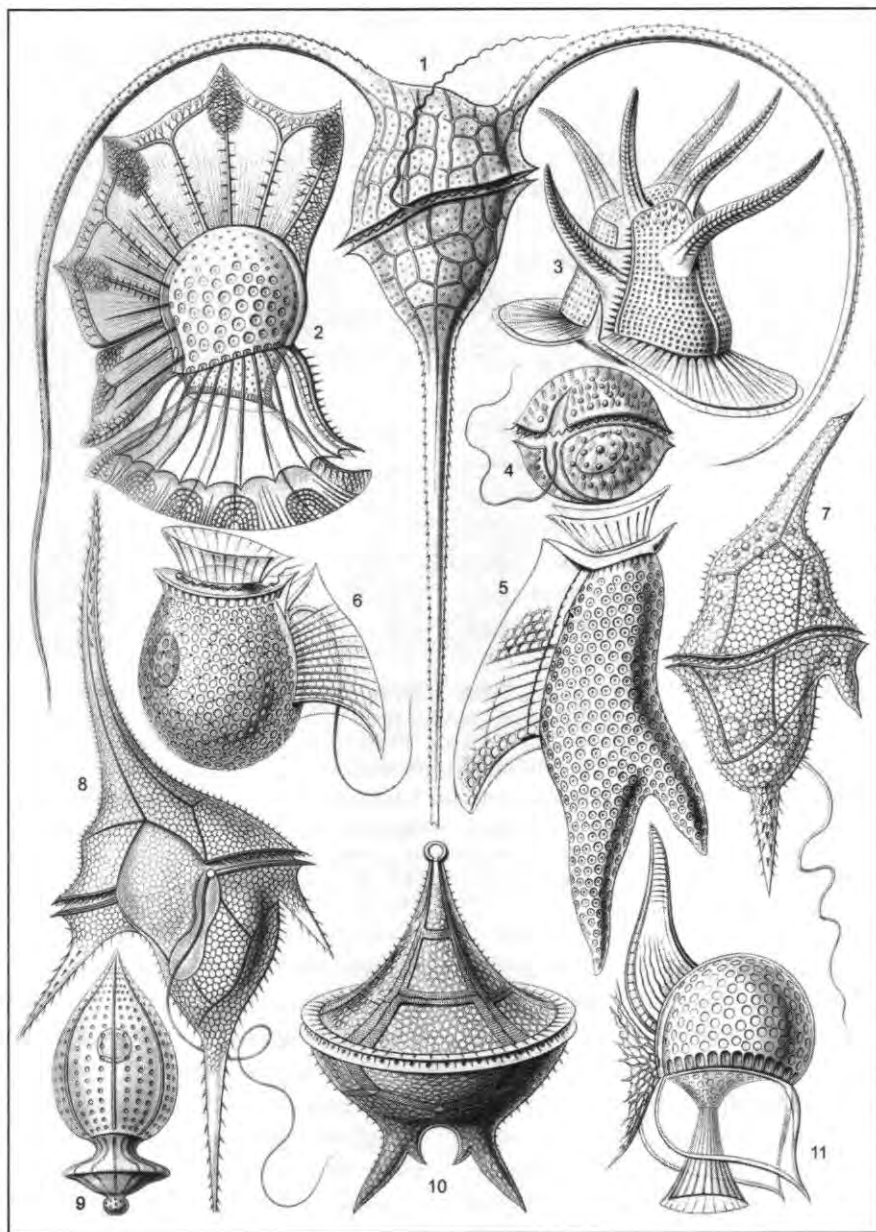

81. Dinoflagellata:
 (Peridinea). 1 — *Ceratium tripos*, 2 — *Ornithocercus magnificus*, 3 — *Ceratocorys horrida*, 4 — *Goniodoma acuminatum*, 5 — *Dinophysis homunculus*, 6 — *D. sphaerica*, 7 — *Ceratium cornutum*, 8 — *C. macroceros*, 9 — *Pyrgidium pyriforme*, 10 — *Peridinium divergens*, 11 — *Histioneis remora* (: Haeckel: *Kunstformen der Natur*. Verlag des Bibliographischen Instituts. Leipzig 1899 1904).

Ceratium;

Gymnodinium mikimotoi, *G. breve* *G. gala theanum*;

Gymnodinium eucyaneum *G. acidotum*;

Lepidodinium viride, *Gymnodinium chlo rophorum*;

Peri dinium balticum, *P. foliaceum*;

Podolampas bipes.

Noctiluca *Oodinium*.

To,

Nocti-

luca scintillans

(
);
2

(. . . 31):

Ornithocercus magnificus, *Citharistes regius*;

(. . . 31).

1

2

2 :
 (3
 Nocti
 luca *Protopteridinium* (. . 285).
 (*Blastodinium*, *Oodinium*).
 (. . . 244)
Zooxanthella, *Symbiodinium* —
 (*Polykrikos*),
 (. . . 237).
 1998
 Warnowiidae
 « » (coral
 bleaching) —
 1
 1997 1998
 Scleractinia. —

30

Alexandrium tamarense, *A. catenella*,
Gambierdiscus toxicus, *Gonyaulax tama-*
rense *Gymnodinium catenatum*.

(ciguatera).

Pfiesteria piscicida

Noctiluca scintillans *Gonyaulax*.

(),

, 440

Dinoflagellata

: Diniferea Syndinea.

Diniferea.
dinea —

Syn-

1

: *Alexandrium*, *Amoeboph-*
rya, *Blastodinium*, *Ceratium*, *Dinophysis*,

Gambierdiscus, Gymnodinium, Lepidodinium, Noctiluca, Oodinium, Ornithocercus, Pfiesteria, Podolampas, Prorocentrum, Protoperidinium, Symbiodinium, Syndinium, Zooxanthella.

Apicomplexa

PERKINSOZOA Noreen

(. 82)

et al. 1999 —

Perkinsozoa

18S

, *Perkinsus*

Colpodella

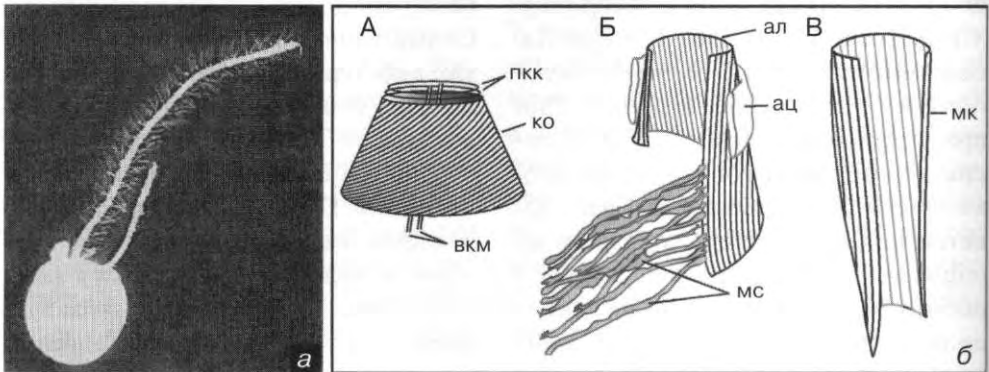

. 82. Alveolata, Perkinsozoa: —

Perkinsus marinus; —

Dinoflagellata (). Apicomplexa (,)

Apicomplexa (A), Perkinsozoa ()

(). *Perkinsus* ():

Amphidinium poecilochroum () (—

). .: — 4 500 .

Perkinsus

Perkinsus

Perkinsus

Parviluci

fera (*P. infectans*)

Alexandrium,

: *Parvilucifera*, *Perkinsus*,

Rastrimonas.

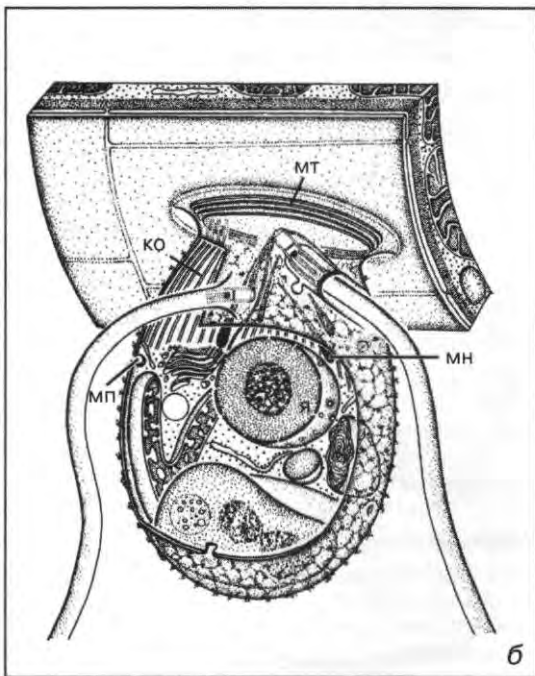
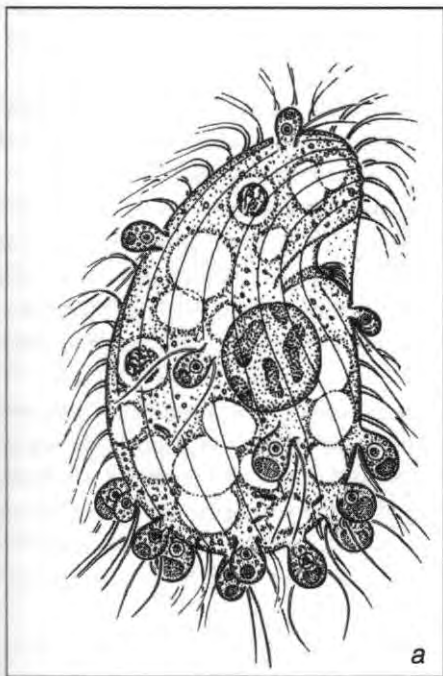

83. Alveolata, Colpodellidae: a — *Colpodella gonderi* (= *Spiromonas*) (Colpoda); — (), (), () (: Foissner and Foissner: Protistologica 20 [1984] 635). : a — 750x, 6 — 7 000x.

Colpodellidae Simpson & Patterson, 1996

Colpodella (*Spiromonas*) —

4800

(. 83).

Colpodella

(. 84).

Perkinsozoa

: *Perkinsus*

(. 85)

Dinoflagellata, a Colpo-

dellidae,

Apicomplexa (. 11).

: *Colpodella*.

APICOMPLEXA Levine,

1970 —

Sporozoa, Apicomplexa

20

2

Apicomplexa

(. 86,

87):

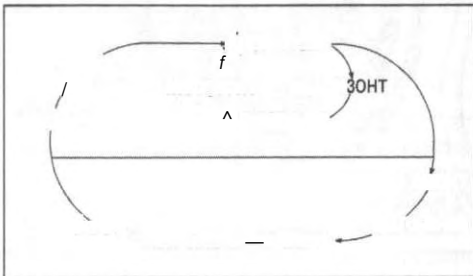

()

. 84. Alveolata, Apicomplexa:

(=),

2 8

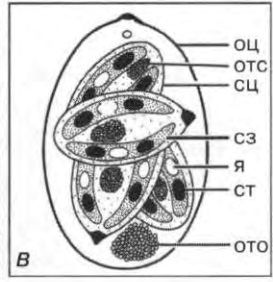
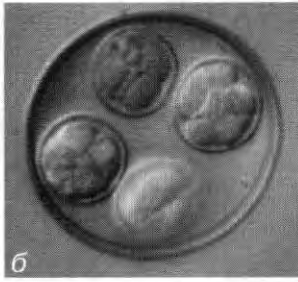
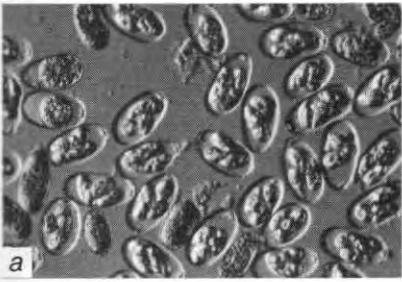

85. Apicomplexa: — *Eimeria stiedae*; — *Eimeria sp.*,
 ; —
 ; —
 (—)
 ; — 1

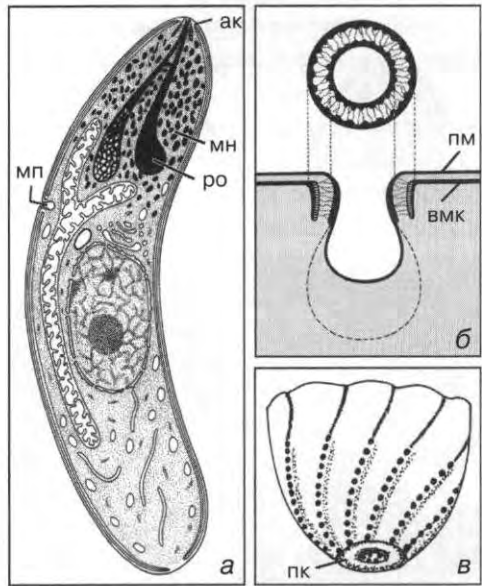

(. 87, 88, 98).

86. Apicomplexa: —
 ; —
 ()
 (), —
 ; (), —
 ; —
 () (—
 rich proteins). —
)

(hystidine

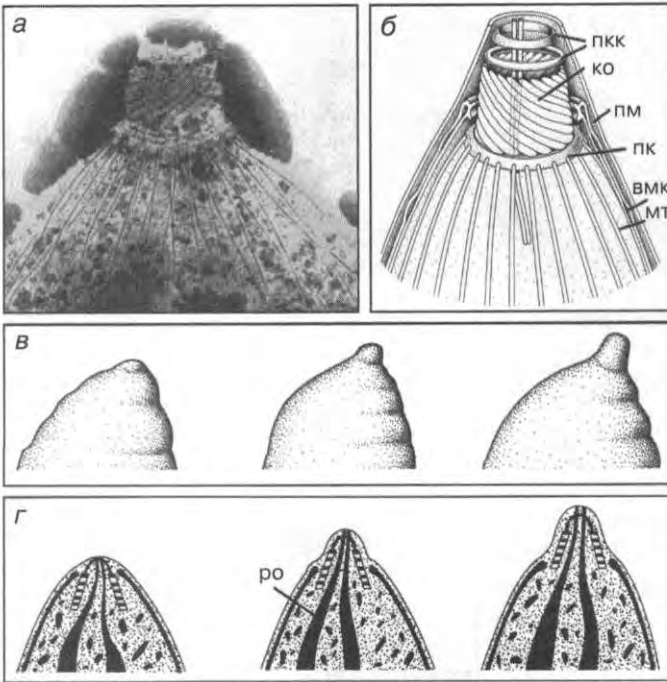

87. Apicomplexa: *Toxoplasma gondii* (Nichols et al.: J. Protozool. 34 [1987] 217; 6 r.). — 35

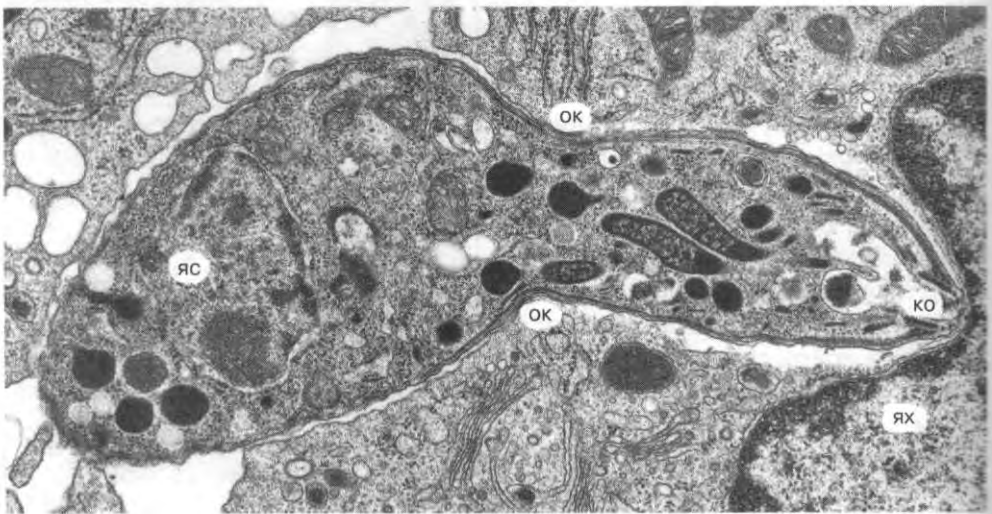

88. Apicomplexa: *Toxoplasma gondii* (Nichols and O'Connor: Lab. Invest. 44 [1981] 324). — 20

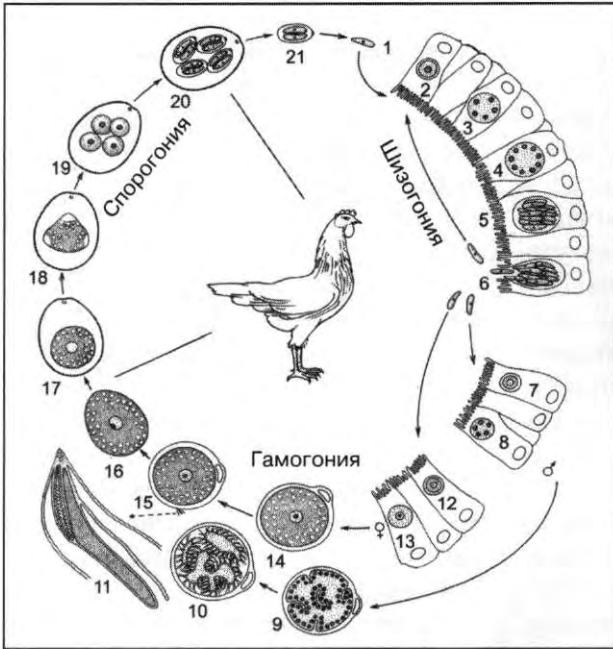

. 89. Apicomplexa: -
Eimeria maxima. 1 -
 , 2 6 - -
 , 7 15 - , 12 14 -
 , 8 11 -
 , 16 -
 (), 17 20 -
 , 21 - ().

Apicomplexa

Eimeria,
Eimeria

1

1

3

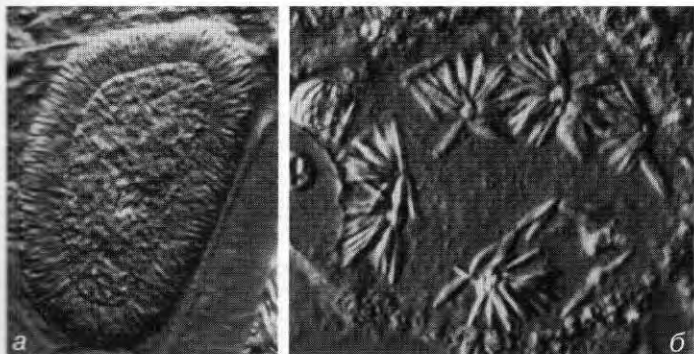
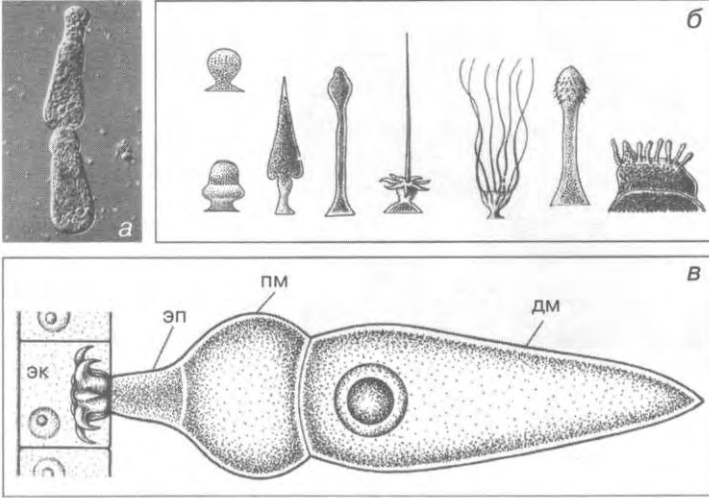

Fig. 90. Apicomplexa:
 () ()
Eimeria canadensis (: Müller et al.: J. Protozool. 20 [1973] 293). .. a — 800x, b — 1 000x.

1977	-		
1978	-		
1979	-		
1980	-		
1981	-		
1982	-		
1983	-		
1984	-		
1985	-		
1986	-		
1987	-		
1988	-		
1989	-		
1990	-		
1991	-		
1992	-		
1993	-		
1994	-		
1995	-		
1996	-		
1997	-		
1998	-		
1999	-		
2000	-		
2001	-		
2002	-		
2003	-		
2004	-		
2005	-		
2006	-		
2007	-		
2008	-		
2009	-		
2010	-		
2011	-		
2012	-		
2013	-		
2014	-		
2015	-		
2016	-		
2017	-		
2018	-		
2019	-		
2020	-		
2021	-		
2022	-		
2023	-		
2024	-		
2025	-		
2026	-		
2027	-		
2028	-		
2029	-		
2030	-		
2031	-		
2032	-		
2033	-		
2034	-		
2035	-		
2036	-		
2037	-		
2038	-		
2039	-		
2040	-		
2041	-		
2042	-		
2043	-		
2044	-		
2045	-		
2046	-		
2047	-		
2048	-		
2049	-		
2050	-		
2051	-		
2052	-		
2053	-		
2054	-		
2055	-		
2056	-		
2057	-		
2058	-		
2059	-		
2060	-		
2061	-		
2062	-		
2063	-		
2064	-		
2065	-		
2066	-		
2067	-		
2068	-		
2069	-		
2070	-		
2071	-		
2072	-		
2073	-		
2074	-		
2075	-		
2076	-		
2077	-		
2078	-		
2079	-		
2080	-		
2081	-		
2082	-		
2083	-		
2084	-		
2085	-		
2086	-		
2087	-		
2088	-		
2089	-		
2090	-		
2091	-		
2092	-		
2093	-		
2094	-		
2095	-		
2096	-		
2097	-		
2098	-		
2099	-		
2100	-		



. 91. Apicomplexa.
 Gregarina: — грегарины
 ; б —
 ; —
 ;
 (),
 (), и
 ()
 (— по:
). : — 85 .

GREGARINEA Dufour, 1828

1465

Apicomplexa

Gregarina, Coccidea Haematozoa.

Conoidasida; Haematozoa

Aconoi

dasida.

(. 91)

1

Neogregarinida

Apicomplexa I

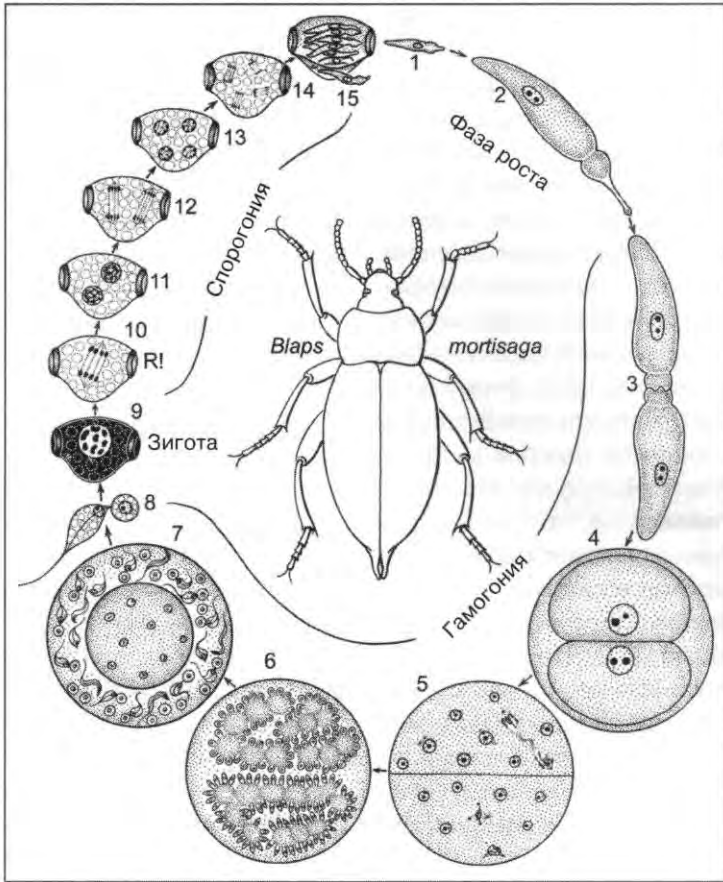

92. Gregarina:

Blaps mortisaga (1 4)

Stylocephalus longicollis.

(5 14).

(1); (2).
 (3).
 (4). (5),
 (6, 7). (7). (7, 8).
 (9). (10).
 8 (11 15).
 () ().
), 4
 (). 16
 ((10)

(. . 269).

2 ;

: Gregarina, Mattesia, Monocystis, Selinidioides, Stylocephalus, Siedleckia.

COCCIDEA Leukart, 1879 —

(. . 916)

()

().

(. 89).

4 32 ()

() ,

(. 92).

2 8 ()

().

Protococcida.

(Archi , Neogrega

rinida).

(),

1

— Eugregarinida —

2 « » — , Sipunculida
Enteropneusta. —

Стр. 134 -
Стр. 135 -
Стр. 136 -
Стр. 137 -

Стр. **Agamococcida** Levine, 1979 —

Агамоккида -

Агамоккида -

Агамоккида -

Агамоккида -

Агамоккида -

Агамоккида -

Агамоккида () -

Агамоккида : *Rhytidocystis*, *Gemmo*
cystis.

Стр. **Protococcida** Kheisin, 1956
(Coelotrophida) —

Протоккида -

Протоккида -

Протоккида -

Протоккида -

Протоккида -

Протоккида -

Протоккида : *Eleutheroschizon*, *Grellia*.

Стр. **Adeleida** Leger, 1911 —

Аделеда -

Аделеда -

Аделеда -

Аделеда -

Аделеда -

Аделеда -

Аделеда -

Аделеда -

Аделеда - 2 4

Аделеда -

Аделеда -

Аделеда -
Аделеда -
Аделеда -

Аделеда -

Аделеда -

Аделеда -

Аделеда -

Аделеда -

Аделеда -

Аделеда () -

Аделеда : *Haemogre*
garina

Аделеда -

Аделеда -

Аделеда : *Klossia*

Аделеда -

Аделеда -

Аделеда : *Adelea*, *Haemogregarina*,

Karyolysus, *Klossia*.

Аделеда -

Eimeriida Leger, 1911 —

Аделеда -

Аделеда -

Аделеда -

Аделеда -

Аделеда -

Аделеда -

Аделеда -

Аделеда -

Аделеда -

Аделеда -

Аделеда -

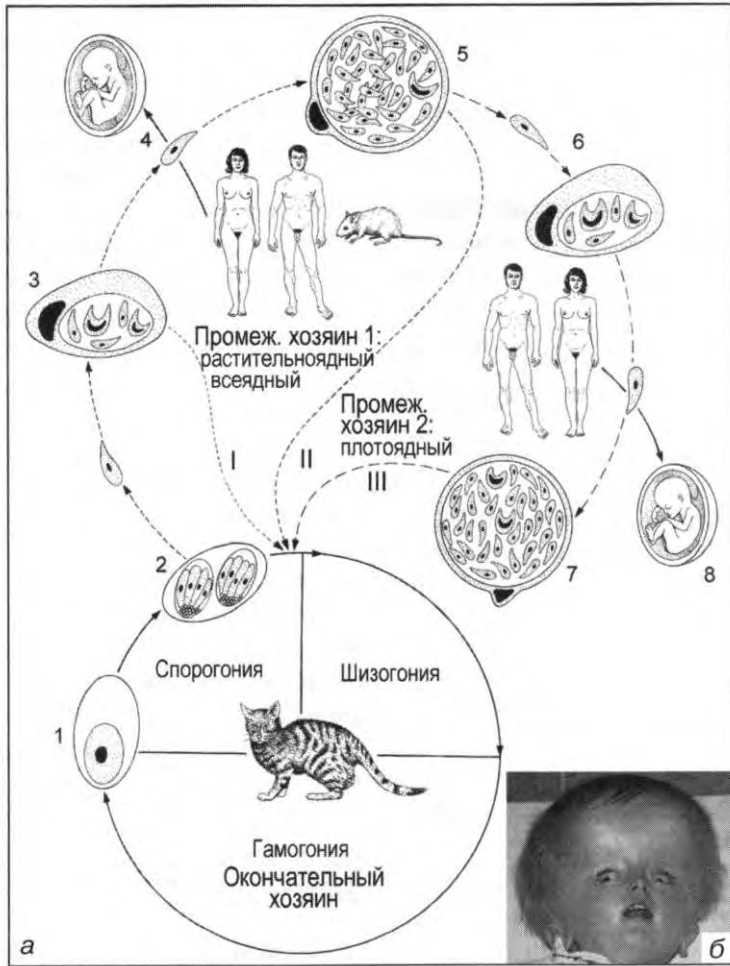

93. Apicomplexa, Coccidia: — *Toxoplasma gondii*. 1 — ; 2 — ; 3 — ; 4 — () (5) () ; 6 — 3 5 (7) (8); (I) — 9 11 ; 2 (III) — 3 ; — 14 (— , —).

450 *Eimeria*
 (4 , 2
 89) *Isospora*
 (2 , 4
)
 {*Toxo-*
plasma, Sarcocystis, Frenkelia}.
Toxoplasma gondii (2
 4)
 (. 93).
Toxo-
plasma gondii

(.
).
 (« »)
 «
 »,
 (...).
 ()
 .

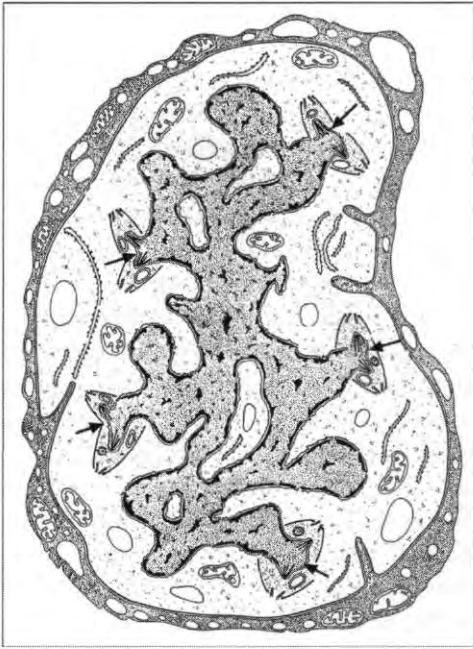

94. Coccidea: *Sarcocystis suis hominis*.

(: Heydorn and Mehlhorn: Zentralbl. bakt. Microbiol. Hyg. 1. AMI., Orig. A, 240 [1978] 123).

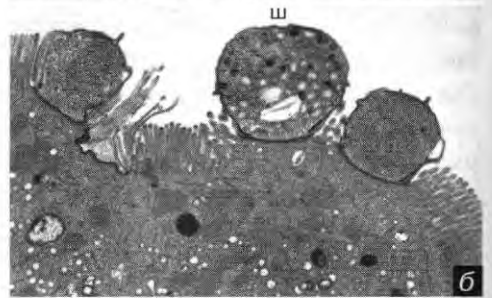
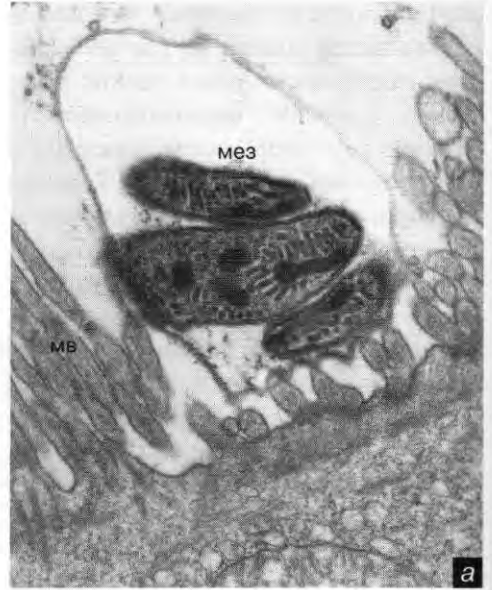

95. Coccidea: *Cryptosporidium parvum*.

Sarcocystis, Aggregata Frenkelia.

()

()

()

, *Sarcocystis suis hominis* (), *S. equicanis*

()

() ()

6 4 500 .

() *S. ovifelis* ()

, ,

(. 94).

Cryptosporidium parvum

(. 95).

dium

Cryptospori-

: *Cryptosporidium*, *Eimeria*, *Frenkelia*, *Isospora*, *Sarcocystis*, *Toxoplasma*.

HAEMATOZOEAE Vivier, 1982

Haematozoa

Aconoidina

Aconoidasida.

(=)

Haematozoa —

mosporida Piroplasmida

Haemosporidia Danilewsky

1885 —

Haemosporidia

Plasmodium ()

()

Anopheles, *Aedes*

Culex;

Plasmodium

(DEC. 96),

(NO 1)

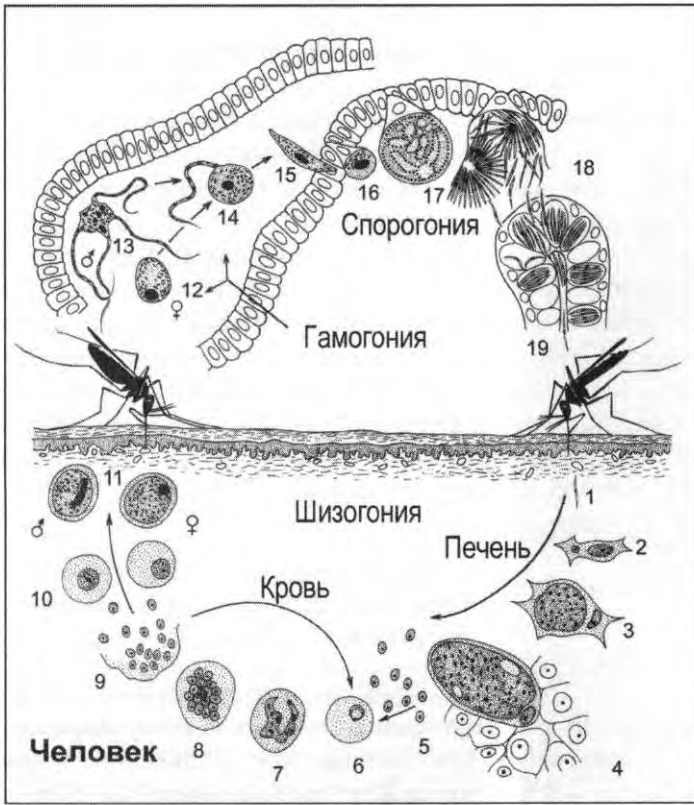

. 96. Apicomplexa,
 Haematozoa: -
Plasmodium
vivax. -
 : 1 5 —
 , 6 9 —
 , 10 11 —
 ;
Anopheles:
 12 —
 , 13 —
 ,
 14 —
 15 — , 16—18 —
 , 19 —
 ()
).

(. 97, 98),

()

()
).

10

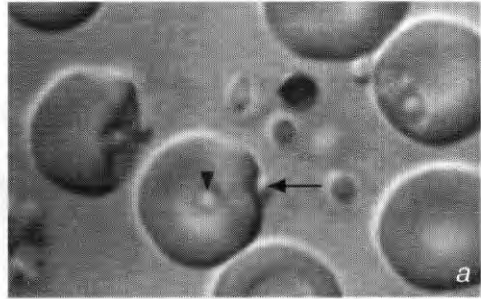

()

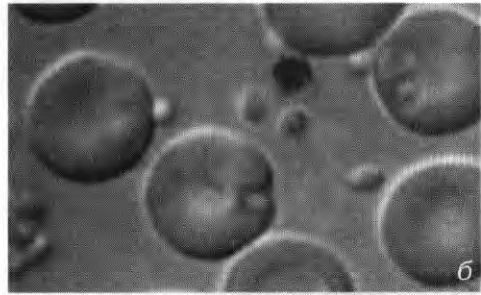

16 °

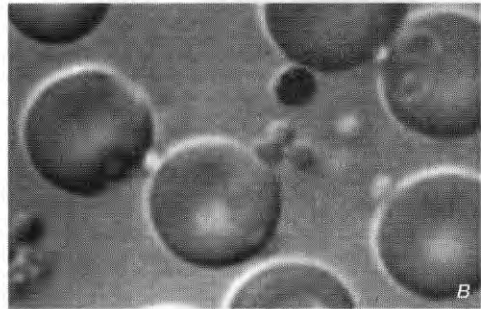

11

Plasmodium,

160

12.

malala

aria —

()

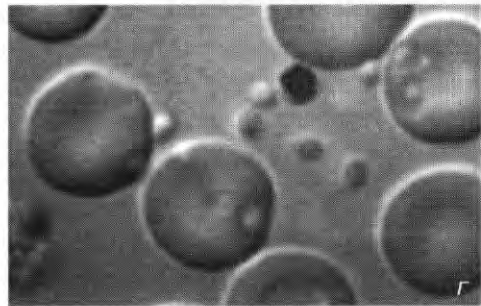

97. Haematozoa: ()

Plasmodium

() ()

100

4

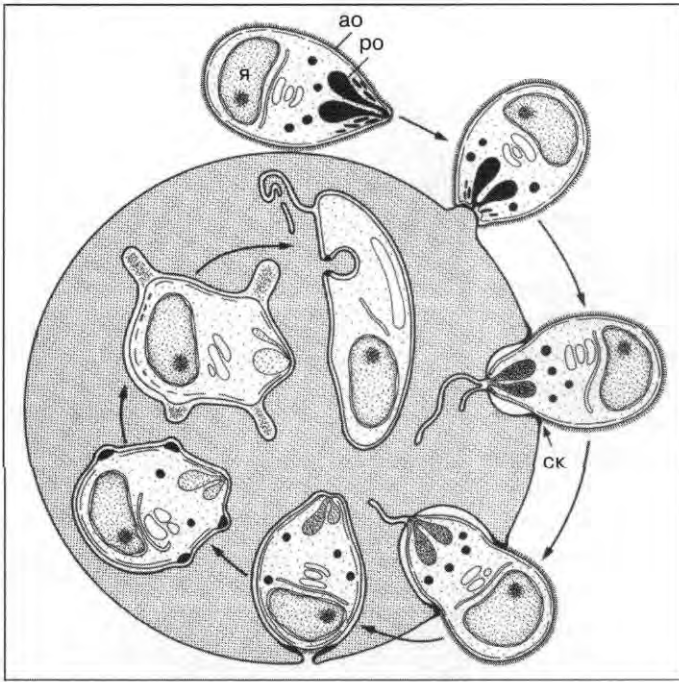

. 98. Haematozoa:

Plasmodium knowlesi

12.

Plasmodium

<i>P. vivax</i>		8 16	48	
<i>P. ovale</i>		15	48	
<i>P. malariae</i>		20 35	72	+/
<i>P. falciparum</i>		7 12		+

; 300

1858 1869

— 18 . XX —
 : « », « —
 », « —
 ».

P. vivax

1997 2000 1996—

dium falciparum.
500 *Plasmo-*
300

Haemosporidia.

(Ixodidae).

5

2

: *Haemoproteus*, *Leucocyto-*
zoon, *Plasmodium.*

Piroplasmida Wenyon,

1926 —

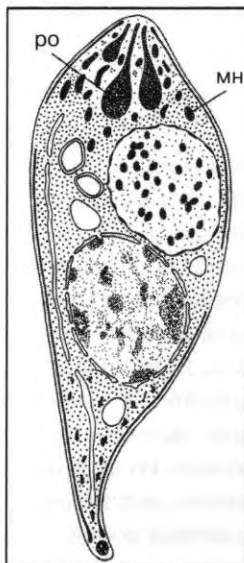

99. Haematozoa: *Babesia bigemina*,

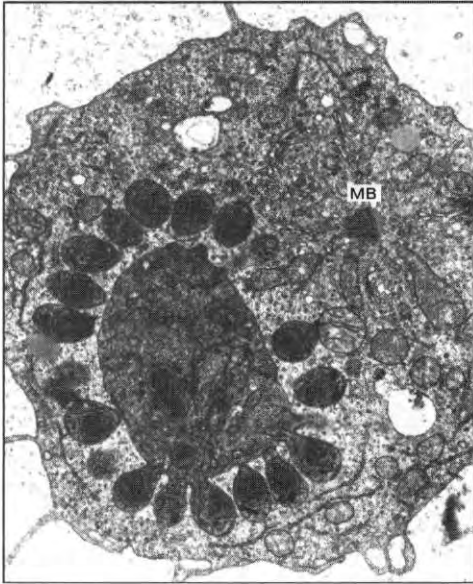

100. Haematozoa:
Theileria annulata

() X.
) : 5 700 .

Babesia

Babesia bigemina

(. 99), 50%. *Babe-*
sia (. *bovis*, . *divergens* . *microti*)

Plasmodium, —

Theileria (.

100).

: *Babesia*, *Dactylosoma*,
Piroplasma, *Theileria*.

CILIOPHORA Doflein,

1901 —

Ciliata

(Perty, 1952) Infusoria (Bütschli, 1887).

8000

(. 101),

: (1)

(2)

(3)

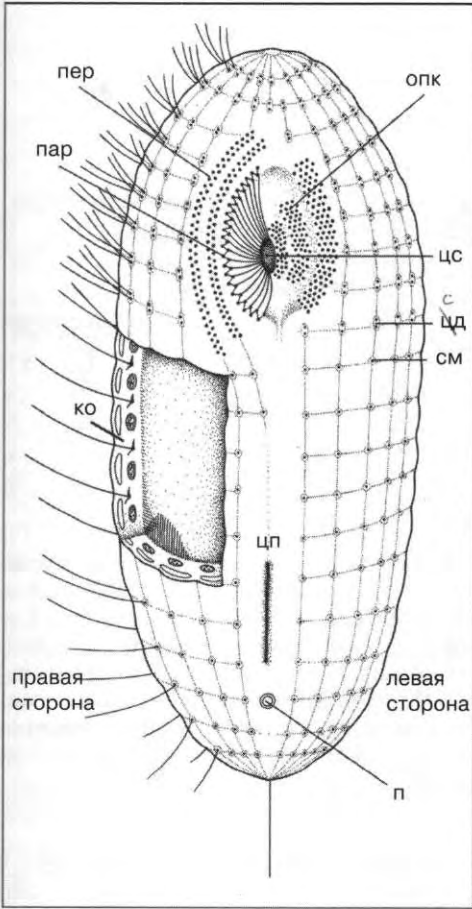

14

: (1) (2)

(*Euplotes*, . 104)

(*Coleps*, . 134),

. 101. Alvelolata, Ciliophora:

105),

(. 102, 103),

), (. 102, 103),

)

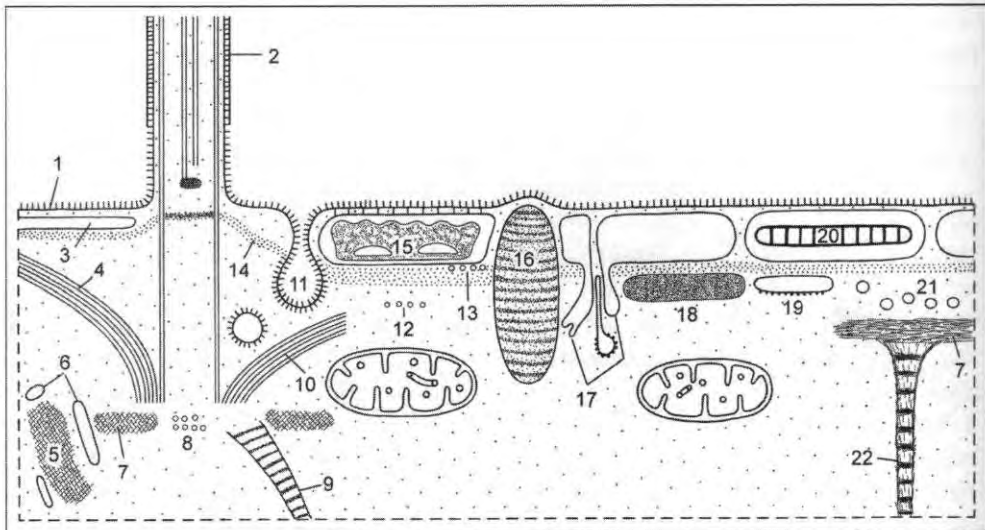

102. Ciliophora:

1 —
 2 —
 3 —
 4 —
 5 —
 6 —
 7 —
 8 —
 9 —
 10 —
 11 —
 12 —
 13 —
 14 —
 15 —
 16 —
 17 —
 18 —
 19 —
 20 —
 21 —
 22 —

() .

() .

(. 106) .

(. 107) .

(. 115) .

(. 108) :

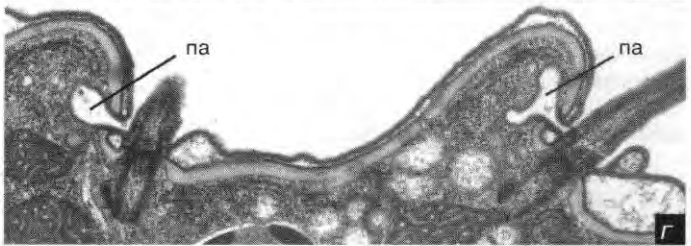
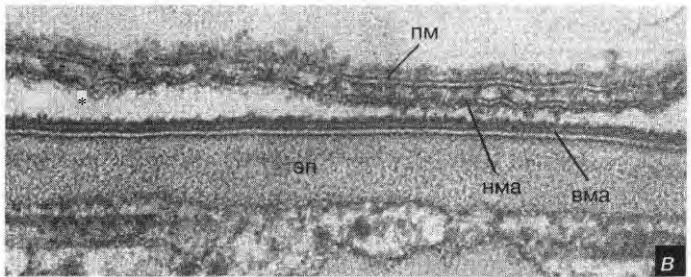
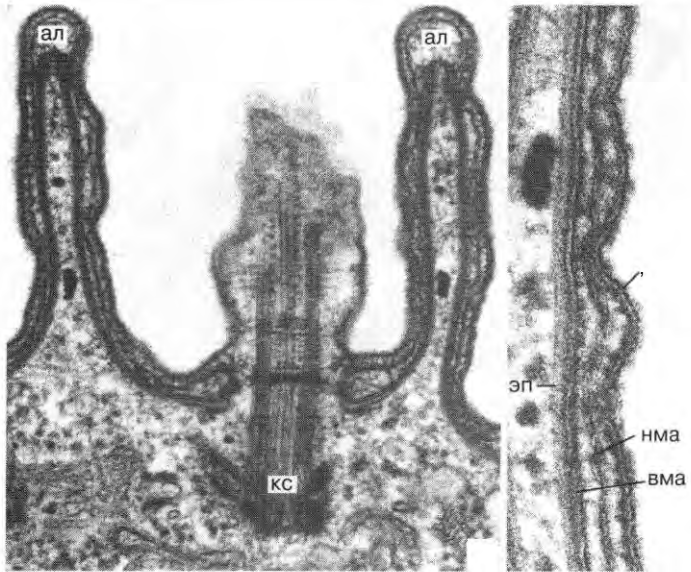

103. Ciliophora:

Paramecium (,) *Pseu*
domicrothorax (,), —

— , —
— , —
— , —
— , —
50 , 6 — 150 ,
160 , — 25 .

— « » ,
— — —
— — —
— — —
Glaucoma ferox;
— — —
() — — — () ,
() . — — — — —

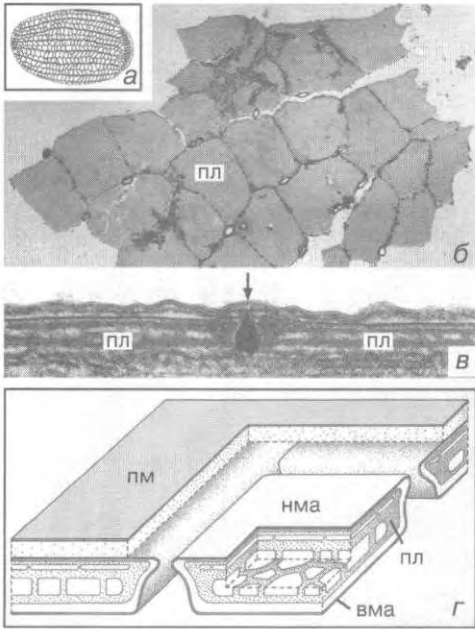

104. Ciliophora:
 ; — ;
 ; — (),
 ;
 — ;
 (: Hausmann and
 Kaiser: J. Ultrastruct. Res. 67 [1979] 15).
 .: a — 250x, б — 2 200x, с — 85 000x.

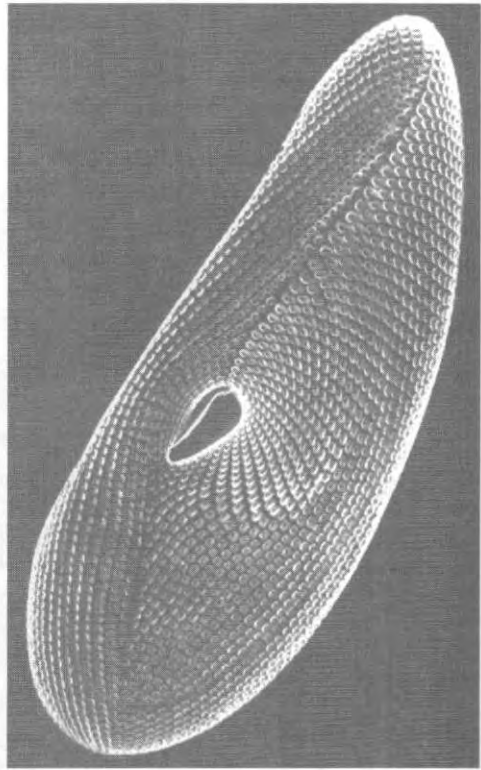

105. Ciliophora:
Paramecium,
 (: Jeanmaire
 et al.: Europ. J. Protistol. 29 [1993] 311).
 .: 600x.

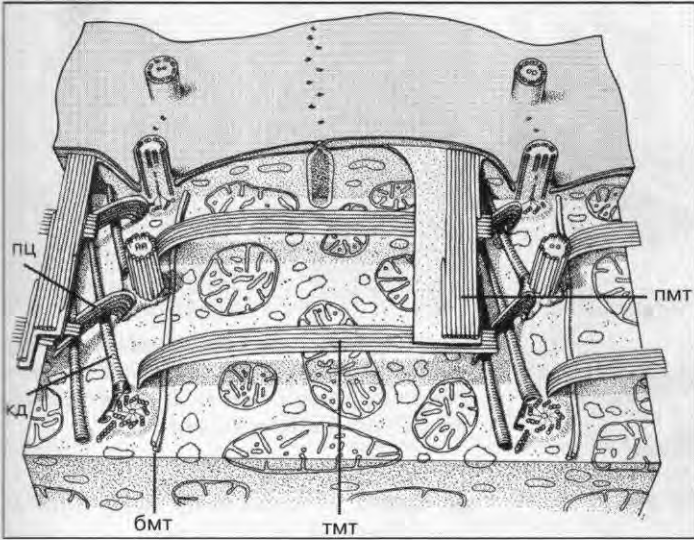

. 106. Ciliophora: -

Tetrahymena.

- -
 - -
 - -
 - -
 - -
 - -
 - -
 () .

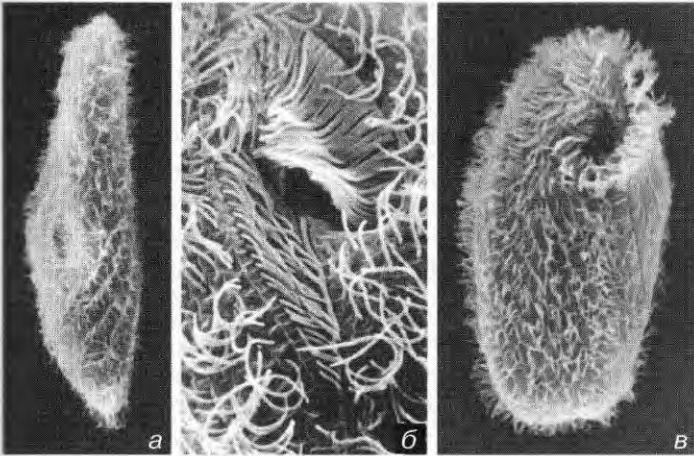

. 107. Ciliophora: -

Para-
mecium (a), Frontonia ()

Climacostomum ()

(-) .

∴ - 270 , -

1 400 , -200 .

Иллюстрация
 к учебнику
 биологии
 животных

: () - () -
 () - () —
 .
 ,
 (. 109).
 ,

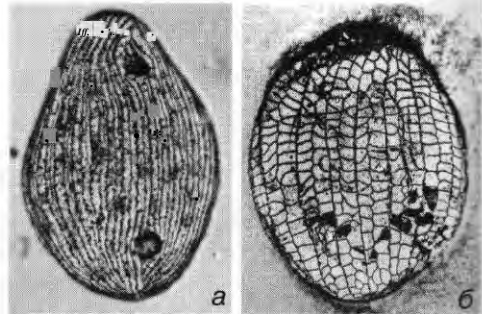
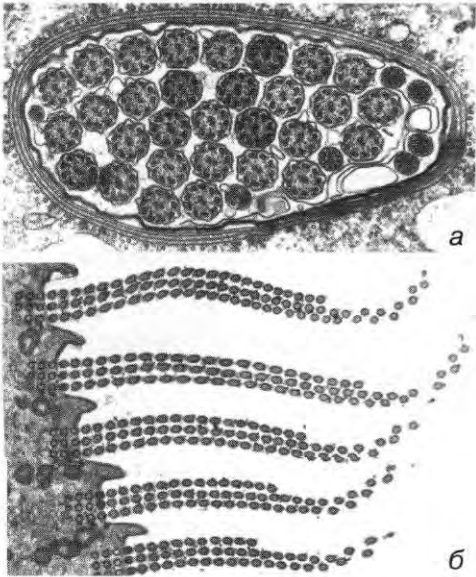

108. Ciliophora: —
Euplotes vannus; —
Euplotes vannus (— :
 Hausmann and Kaiser: J. Ultrastruct. Res. 67
 [1979] 15). : a — 24000x, 6 — 1 700x.

109. Ciliophora:
Colpidium () *Euplotes* () (—
). : — 450 .

() (. 112).

(2 5),

(. 113).

111, 215).

(. 106,

(. 114).

(Karyorelictida !

. 110. Ciliophora:

(I III)

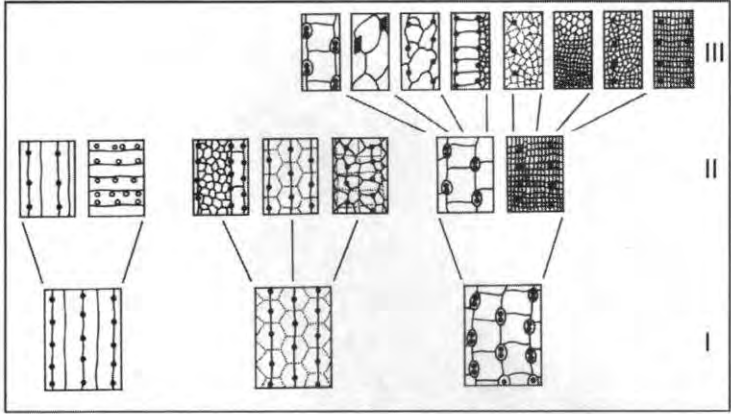

. 111. Ciliophora:
Paramecium caudatum.

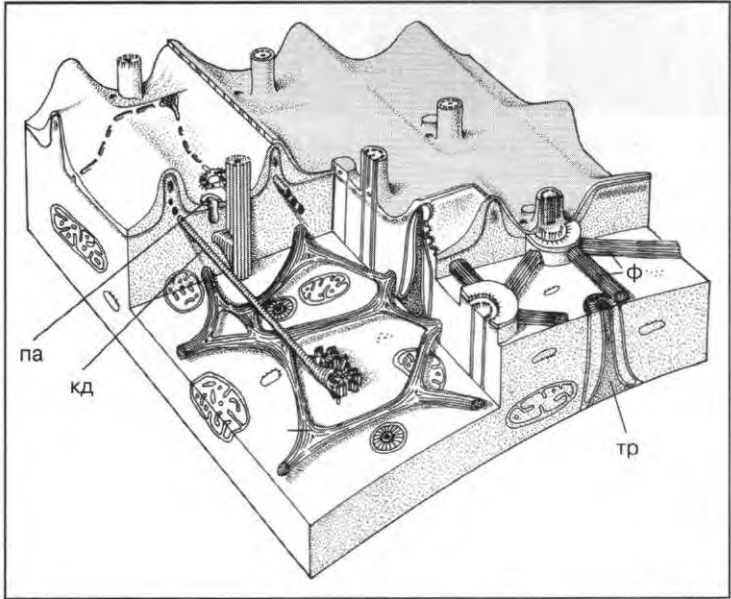

Ciliophora (. 1146).

Ciliophora

(Bütschli) (),

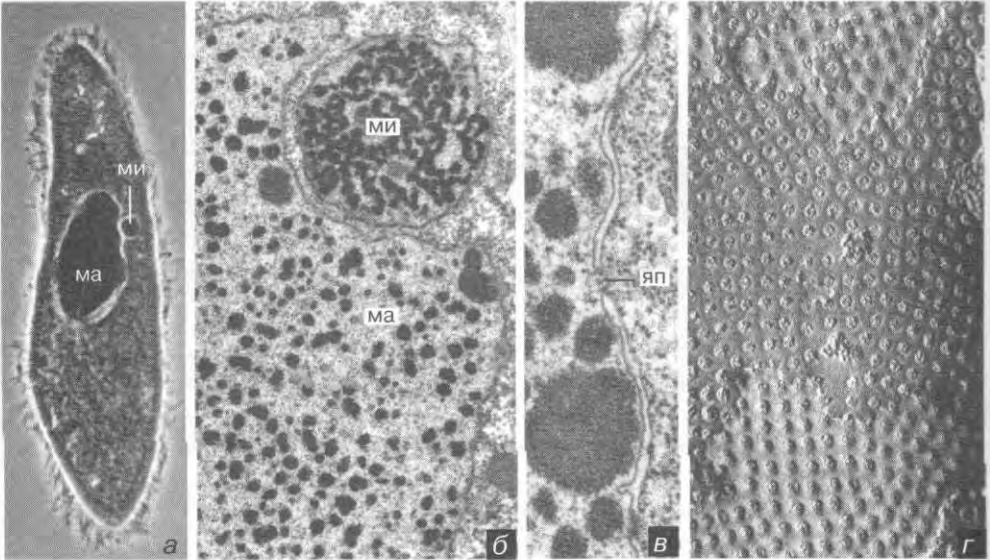

112. Ciliophora: *Paramecium* (), *Colpidium* (,); — *Paramecium*, — (—). : — 400 , — 15 , — 60 , — 40 .

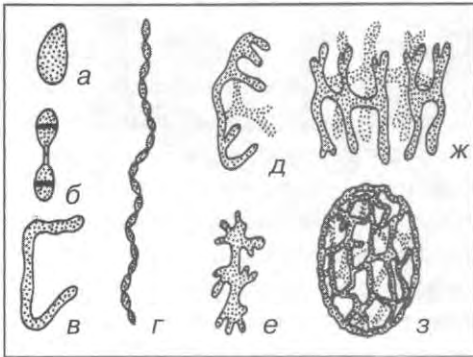

113. Ciliophora: — *Paramecium*, — *Stylonychia*, — *Vorticella*, — *Spirostomum*, — *Ophryodendron*, — *Conchophthirius*, — *Ephelota*, — *Metaphrya* ().

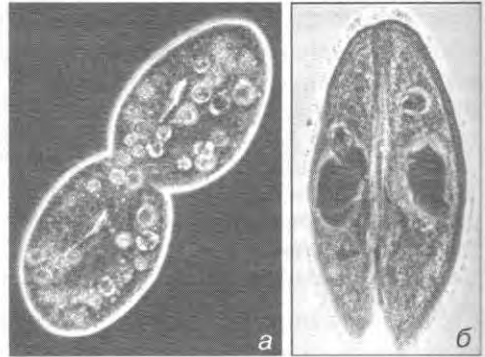

114. Ciliophora: *Paramecium* () (). : — 250 , — 290 .

Holotricha, Chonotricha, Peritricha, Spirotricha Suctorina. 1970

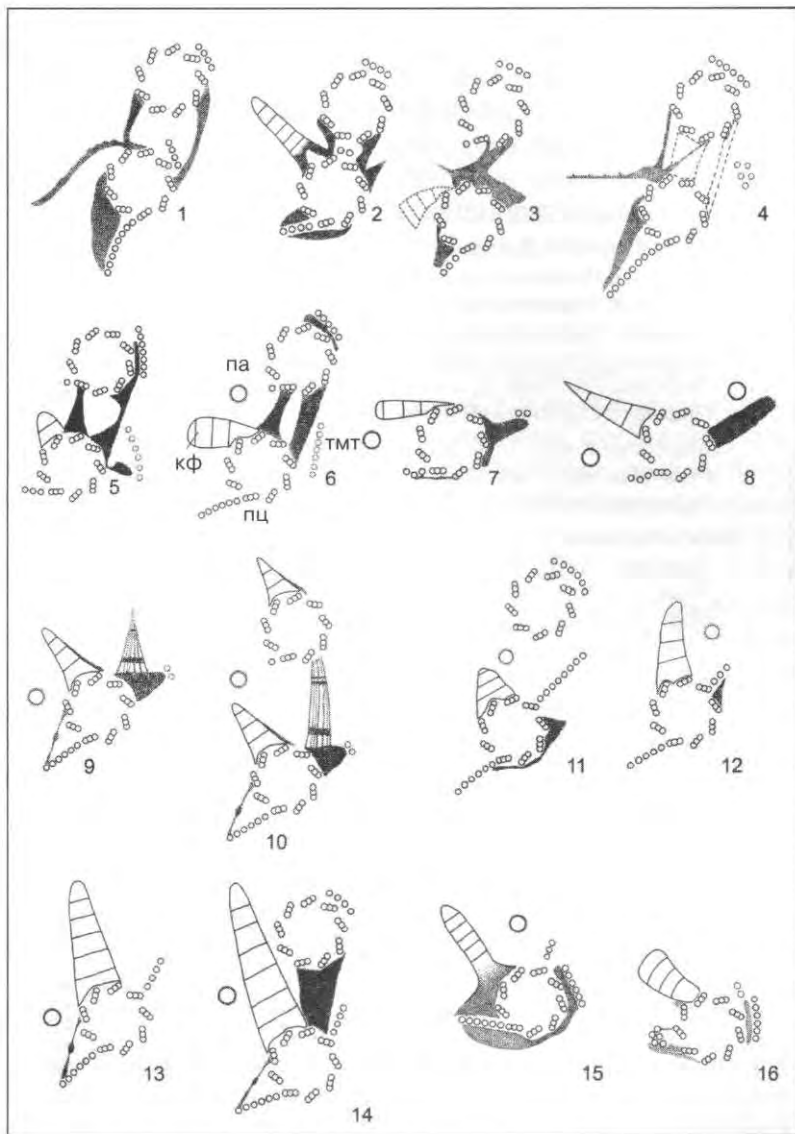

115. Ciliophora:

- (), (), Karyorelictea: *Geleia* (1) *Proto*
cruzia (2); Spirotrichea: *Stylonychia* (3) *Climacostomum* (4); Colpodea: *Sorogena* (5)
Pseudoplatyophrya (6); Phyllopharyngea: *Hypocoma* (7) *Trichophrya* (8); Nassophorea:
 (9) (10) *Nassula*; Oligohymenophorea: *Colpidium* (11) *Ichthyo*
phthirus (12); Prostomatea: (13) (14) *Coleps*; Litostomatea:
Epidotrachelophyllum (15) *Isotricha* (16) ().

CILIOPHORA Doflein, 1901**POSTCILIODESMATOPHORA** Gerassimova & Seravin, 1976

Karyorelictea Corliss, 1974

Heterotrichea Stein, 1859

INTRAMACRONUCLEATA Lynn, 1996

Spirotrichea Biitschli, 1889

Protocruziidia de Puytorac et al., 1984

Phacodiniidia Small & Lynn, 1985

Hypotrichia Stein, 1859

Choreotrichia Small & Lynn, 1985

Stichotrichia Small & Lynn, 1985

Oligotrichia Biitschli, 1887

Litostomatea Small & Lynn, 1981

Haptoria Corliss, 1974

Trichostomatia Biitschli, 1889

Phyllopharyngea de Puytorac et al., 1974

Phyllopharyngia de Puytorac et al., 1974

Rhynchodia Chatton & Lwoff, 1939

Chonotrichia Wallengren, 1895

Suctoria Claparède & Lachmann, 1858

Nassophorea Small & Lynn, 1981

Colpodea Small & Lynn, 1981

Prostomatea Schewiakoff, 1896

Plagiopylea Small & Lynn, 1985

Oligohymenophorea de Puytorac et al., 1974

Peniculia Faure Fremiet in Corliss, 1956

Scuticociliatia Small, 1967

Hymenostomatia Delage & Herouard, 1896

Apostomatia Chatton & Lwoff, 1928

Peritrichia, Stein, 1859

Astomatia Schewiakoff, 1896

ca: Kinetophragminophorea (

),

Oligohymenophorea (

)

Polyhymenophorea (

).

(. 115).

(... 13).

POSTCILIODESMATOPHORA
Gerassimova & Seravin, 1976

(
Oligotrichia Stichotrichia).

(Karyorelictea),

(Heterotrichia).

KARYORELICTEA Corliss,
1974 —

(... 116)

(*Protocruzia* Spirotrichea).

: Proto
stomatida, Loxodida Protoheterotrichida.

Karyorelictida (
Holotricha)

Loxodida;

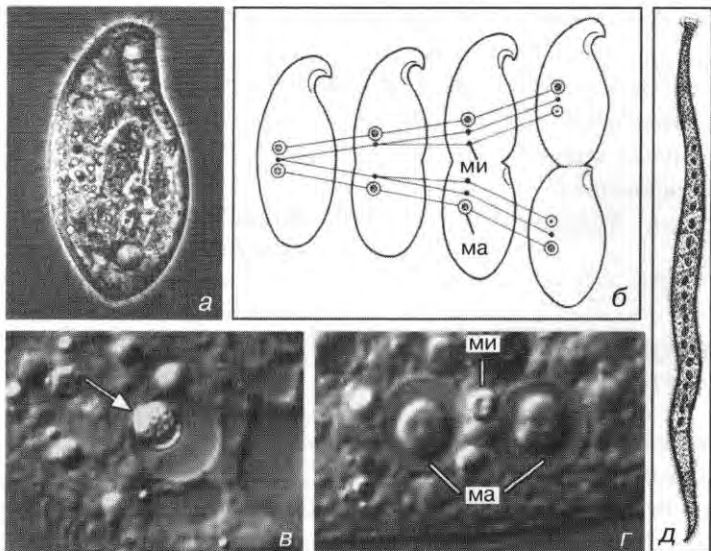

116. Ciliophora, Postciliodesmatophora, Karyorelictea: — *Loxodes*; — () ; — () ; — *Loxodes* () ; — *Loxodes*; — *Trachelocerca* (— ; — ; — : Dragesco: Trav. Biol. Roscoff 12 [1960] 1). : a — 220x, — 2 , — 170 .

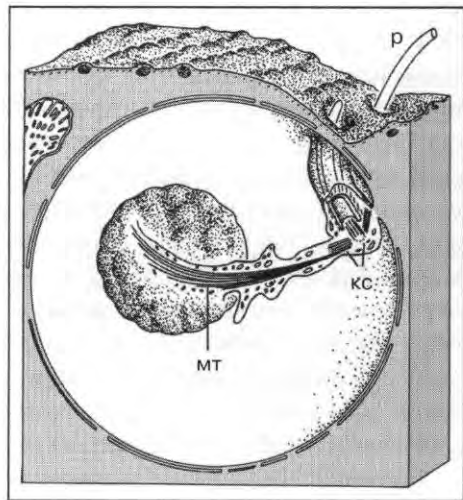

117. Postciliodesmatophora, Karyorelictea: *Loxodes*.

(. 117), , -

: *Trachelocerca*, *Trachelonema*, *Tracheloraphis* (Protostomatida); *Loxodes*, *Remanella* (Loxodida); *Avelia*, *Geleia* (Protoheterotrichida).

HETEROTRICHEA Stein,

1859 —

Heterotrichea (Spirotrichea)

(. 118).

() .

() ,
() . — () .

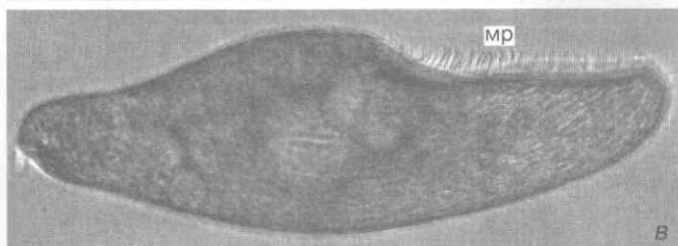
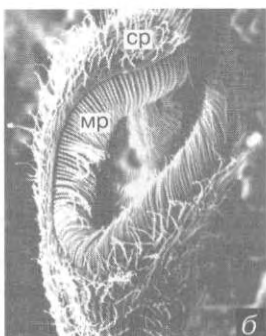
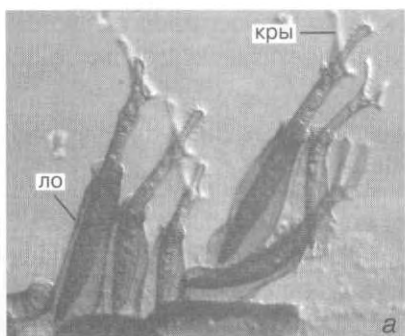

118. Postciliodesmatophora, Heterotrichea: — *Eufolliculina* ()

() ;
 () *Eufolliculina*
 () ; — *Blepharisma*.
 : — 75 , 6 — 2 500 ,
 —

(Licnophorida
 Heterotrichida),

Folliculinidae,

Heterotrichida Stein, 1859

2 ;
Spirostomum,
Stentor
Blepharisma ; *Stentor coeruleus*
 , a *Stentor igneus* —
 Heterotrichida

; (. 118).
 : *Blepharisma*, *Condylostoma*,
Folliculina, *Peritromus*, *Spirostomum*,
Stentor.

INTRAMACRONUCLEATA

Lynn, 1996

Peritricha (. 264).

(
 Postciliodesmatophora).

; (. 13).

(Protocruziidia Phacodi
niidia), sedis mutabilis.

SPIROTRICHEA Biitschli,

1889 —

Protocruziidia de Puytorac

etal. 1987

(.) .

: *Protocruzia*.

Phacodiniidia Small &

Lynn, 1985

119).

: *Phacodinium*.

sedis mutabilis¹ (Armophorida,

Odontostomatida Clevelandellida).

Protocruziidia

²,

Hypotrichia Stein, 1859 —

(. . 299) —

Spi-
rotrichea,

Hypotrichia, Choreotrichia, Stichotrichia

Oligotrichia

Nassophorea (.), что

¹ Sedis mutabilis —

¹

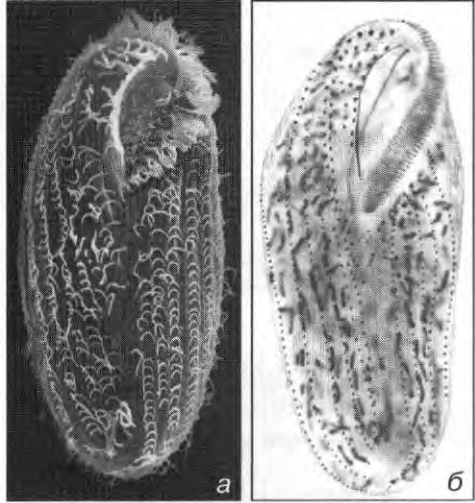
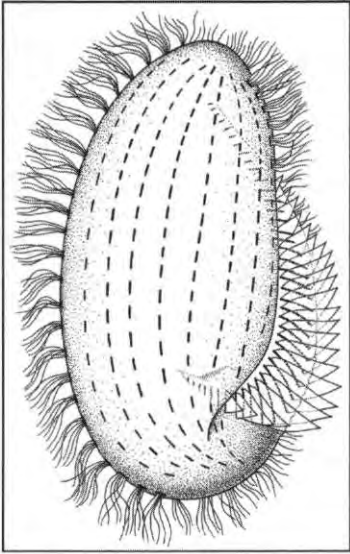

119. Ciliophora, Intramacronucleata, Spirotrichea:
Phacodinium metchnikoffi ().
 : 540 .

120. Spirotrichea:
Urostyla grandis:
 ()
 () ()
) . : — 190 .

Stichotrichia:

(. 120,
 121).

, Hypotrichia,
 , Stichotrichia Oligotrichia,
 —
 Stichotrichia Hypo-
 trichia
 (Oligotrichia).

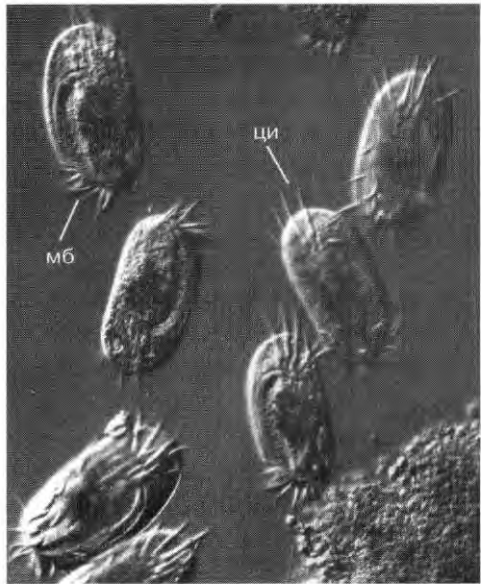

: *Aspidisca*, *Euplotes*, *Uro-
 nychia*, *Urostyla*.

121. Spirotrichea: *Euplotes*
 () () . : 260 .

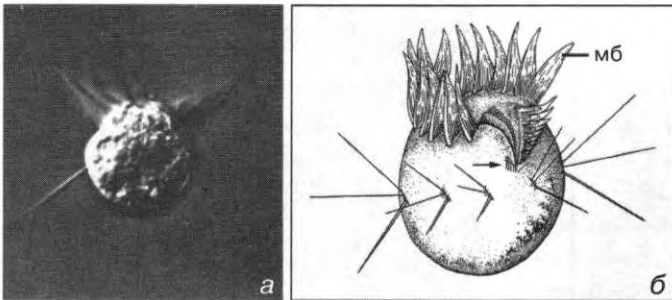

122. Spirotrichea:
Halteria ()
 ()
 () (—
)
 — 500 , — 700 .

Oligotrichia Biitschli,

1889 — ,

(40)

(. 122).

: *Halteria*, *Strombidium*,
Tontonia.

Choreotrichia Small &
 Lynn, 1985

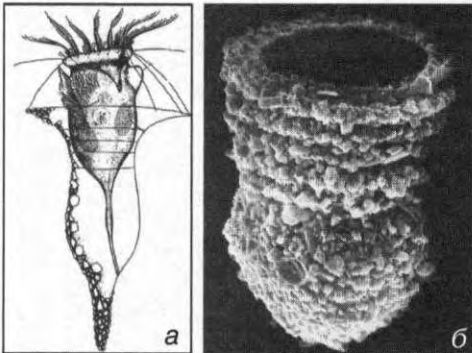

Choreotrichia

Tintinnina,

123. Spirotrichea: — *Tintinnopsis*

123).

; — *Codonella* (—

; — : Barnatzky et al.: Zool.
 Scripta 10 [1981] 81) : a — 650x, —
 720x.

Choreotrichia

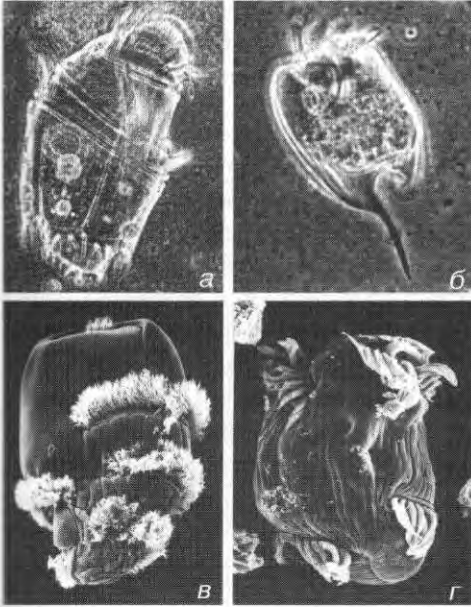

Fig. 126. Litostomatea: — *Ophryoscolex*; — *Entodinium*; — *Trogloditella gorillae*; — *Tetratoxum parvum* (— 190, — 220, — 440).



Fig. 127. Intramacronucleata, Phyllopharyngea: *Chilodonella* (— 680).

Phyllopharyngia (phyllae),
 Nassophorea.

Phyllopharingia
 Puytorac et al., 1974

Chilodonella
 (— 127)
 : *Chlamydodon*, *Chilodonna*, *Chitonella*, *Dysteria*.

Rhynchodia Chatton & Lwoff, 1937

Suctoriozoa Claparède & Lachmann, 1858 —

(),
: , *Crebricoma*.

Chonotrichia Wallengren, 1895 —

(. 129). **Chonotrichia**, су-

(),

(. 128).

: *Heliochona*, *Spirochona*,
Stilochona.

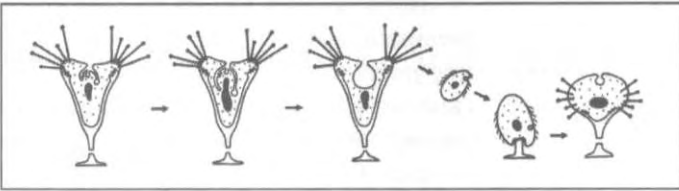
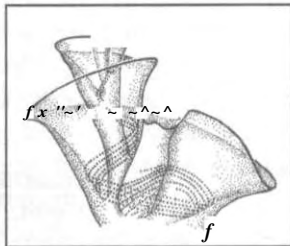
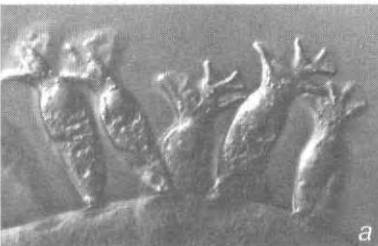

. 128. Phyllopharyngea
— *Spirochona gemmipa*
ra
(—
; — 200

. 129. Phyllopharyngea
Acineta ()
).

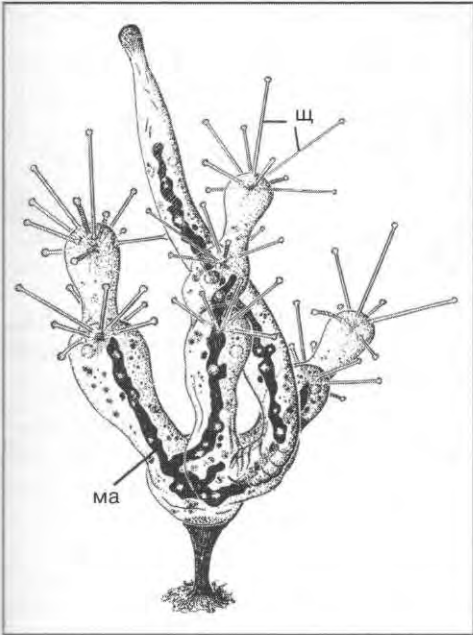

130).

(. 131).

130. Phyllopharyngea:
Dendrosomides grassei,
 (: Batisse: Protistologica 22
 [1986] 11) : 550 .

: *Dendrocometes*, *Discoph*
Ephelota, *Tokophrya*.

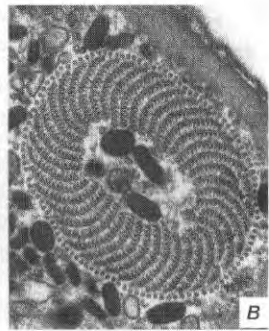
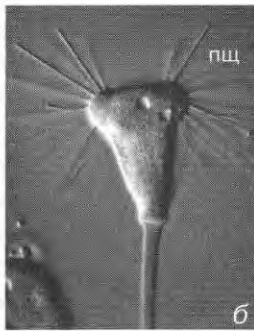
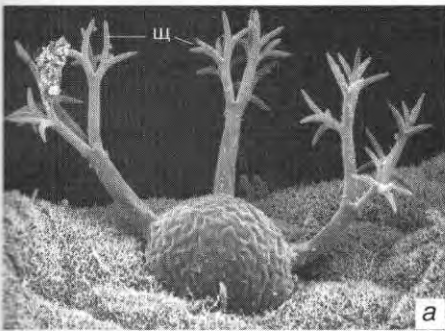

131. Phyllopharyngea: — *Dendrocometes* (); —
Tokophrya (); — *Acinetopsis*
 (—); —
 : Grell and Meister: Protistologica 18 [1982] 67).
 : a — 450x, — 320x, — 22 .

NASSOPHOREA Small & Lynn,
1981

(. 132).

: *Furgasonia*, *Nassula*.

Microthoracida Jankowski,
1967

Nassulida,
Microthoracida

279, 281).

: *Microthorax*, *Pseudomic
rothorax*.

Hypotrichia,

Spirotrichia, Nassophorea

Nassophoria.

COLPODEA Small & Lynn,

1981 —

Colpodea

Colpoda O.F. M tiller, 1773. 150

Synhymeniida de Puytorac et
al., 1974

(. 115).

(),

: *Synhymenia*.

Nassulida Jankowski, 1967

Colpodea

(>100)



Рис. 132. Intramacronucleata, Nassophorea: *Nassula ornata* (),
 (,).
 (), —
 : — 120 , — 350 , — 240 , — 47

(.
 1J3),
 : Bresslaua, Bursaria, Col
 poda, Hausmanniella, Sorogena.

(2) Bursaria
 truncatella

PROSTOMATEA Schewiakoff,
 1896

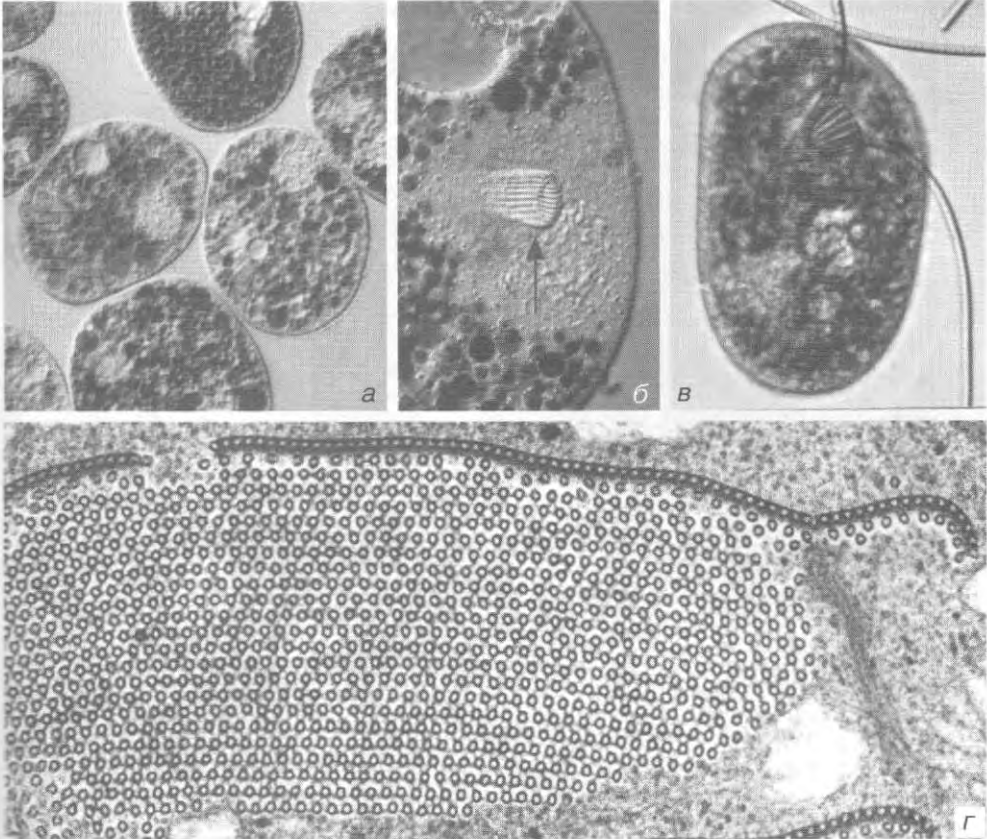
Prostomatea

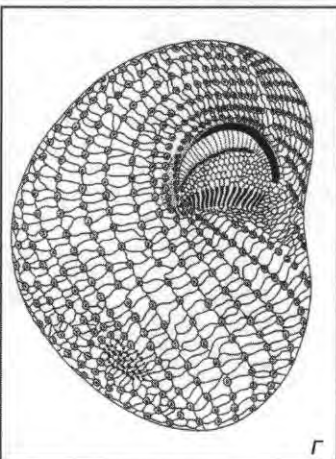
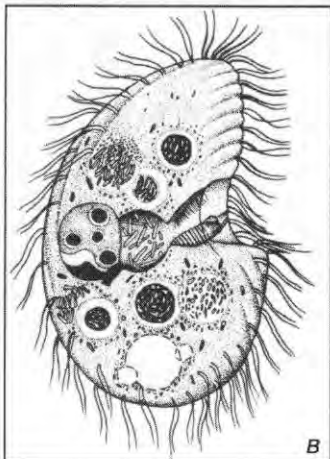
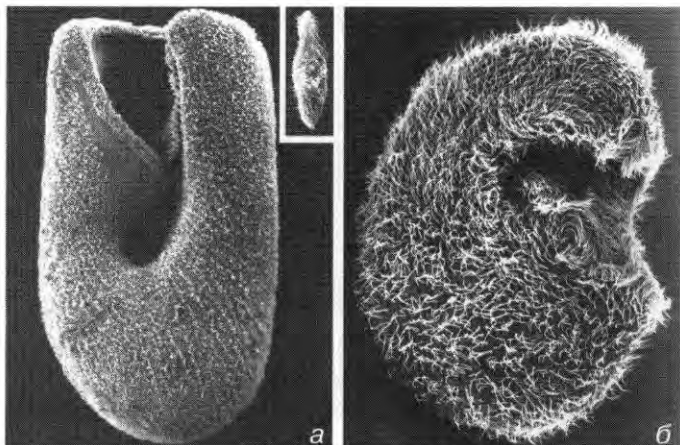

133. Intramacro-
nucleata, Colpodea: —
Bursaria truncatella (

Paramecium);
— *Bresslauides australis*;
— *Colpoda* (—
); — *Hausmanniella*
(—
) (—
; — : Piatt
and Hausmann: Arch.
Protistenk. 143 [1993] 297:
—)
: — 90 , — 480 .
— 550 , — 500 .

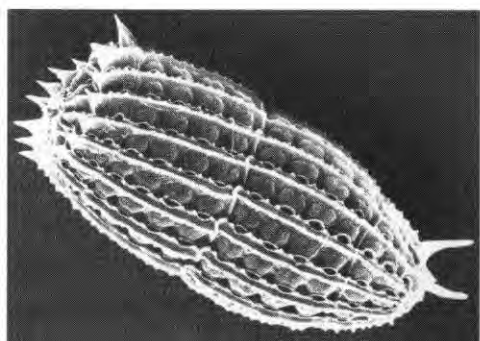

134. Intramacronucleata, Prostomatea:
Coleps hirtus (

(. 134).

: *Coleps*, *Holophrya*, *Pro-*
rodon.

PLAGIOPYLEA Small & Lynn,
1985



Рис. 135. Intramacronucleata, Plagiopylea:

Plagiopyla frontata (

). : 900 .

Величина, мкм, - ()

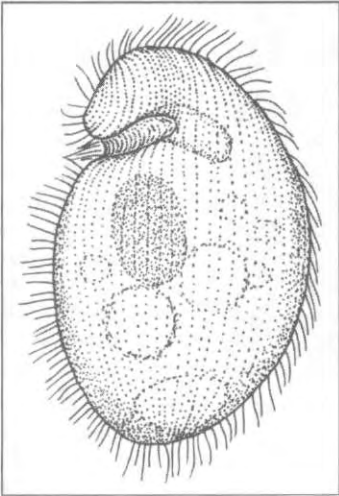
Сфера, мкм, ()

Безжелезистый, мкм, ()

Зона, мкм, -

Личинка, мкм, -

Микро, мкм, ;

• : (. 135).

: *Plagiopyla*, *Sonderia*.

Класс OLIGOHYMENOPHOREA

de Puytorac et al., 1974

Сфера, мкм, -

Безжелезистый, мкм, -

Личинка, мкм, -

Микро, мкм, () -

Сфера, мкм, -

Зона, мкм, -

Класс **Ciliophora**.

Сфера, мкм, -

Безжелезистый, мкм, -

» («) (. .

1376).

Nassophorea,

() ,

() ,

() ,

() .

Peniculia Faure Fremiet,

1956

Peniculia -

Oligohymenophorea:

« » (.

() -

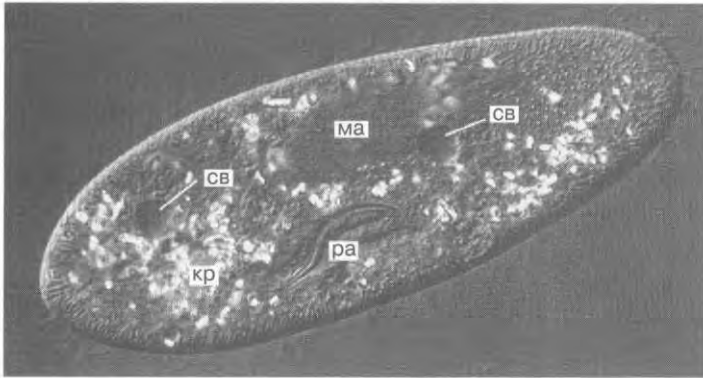

. 136. Intramacronu-
cleata, Oligohymeno-
phorea: *Paramecium*
caudatum. — —
, — —
, pa — —
, — —
450 .

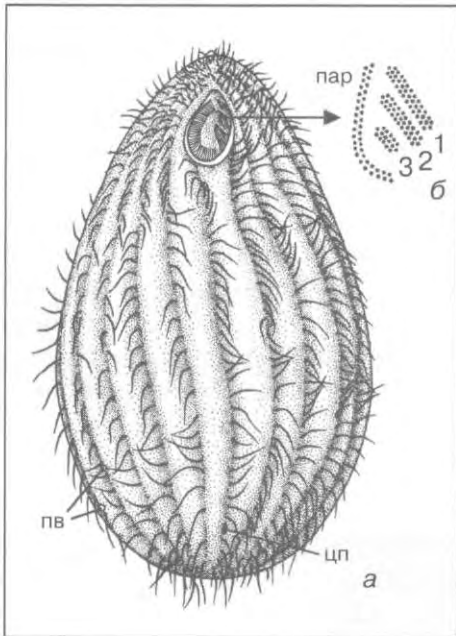

. 137. Oligohymenophorea:
Tetrahymena. — — ;
(1 3) (), — ()
, — ()
) . : — 1 200 .

, *Tetrahymena* (. 137).
;
,
—
— *Paramecium caudatum*.
: *Frontonia*, *Paramecium*.

Scuticociliata Small, 1967

Hymenostomatia,
Scuticociliata
;

Paramecium (. 136) , — *Cyclidium*, *Orchitophna*,
Philasteria, *Pleuronema*, *Uronema*.

Hymenostomatia Dellage
& Hérouard, 1896

Hyme-

nostomatia

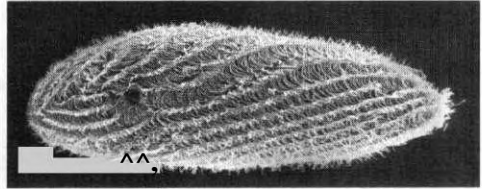

138. Oligohymenophorea: *Ophryoglena atra* (

Одн : -
Жив ,
Класс ,
Ряд (= -
Сем. = , = -
Род).
Линн .
Именн .
Обл. (. 137).
Ступ .
Му .
Класс ,
Мир, *Ophryoglena*
Три .
Ты .

). : 320 .
; ;
(. 139).
:
: *Colpidium, Ichthyophthi-
rius, Ophryoglena, Tetrahymena.*

Hymenostomatia

Apostomatia Chatton &
Lwoff, 1928 —

Нена .
Вид .
Кл .
Три .
Животн .
Ichthyophthirus (*Ophryoglena*)¹ (. 138).
Мир .
> *Tetrahymena pyriformis* (рис. 137) . *thermophila:*
Рост .
Вид .
Класс .
Линн .
Именн .
Обл .
Ступ .
Му .
Класс .
Мир, *Ichthyophthirus*
Три .
Ты .
Инду .
Мир .

Вид .
Кл .
Три .
Животн .
Мир .
(. 140).
(.)
(.) .
:
Foettingeria, Hyalophysa, Spirophrya.

¹ Инду...

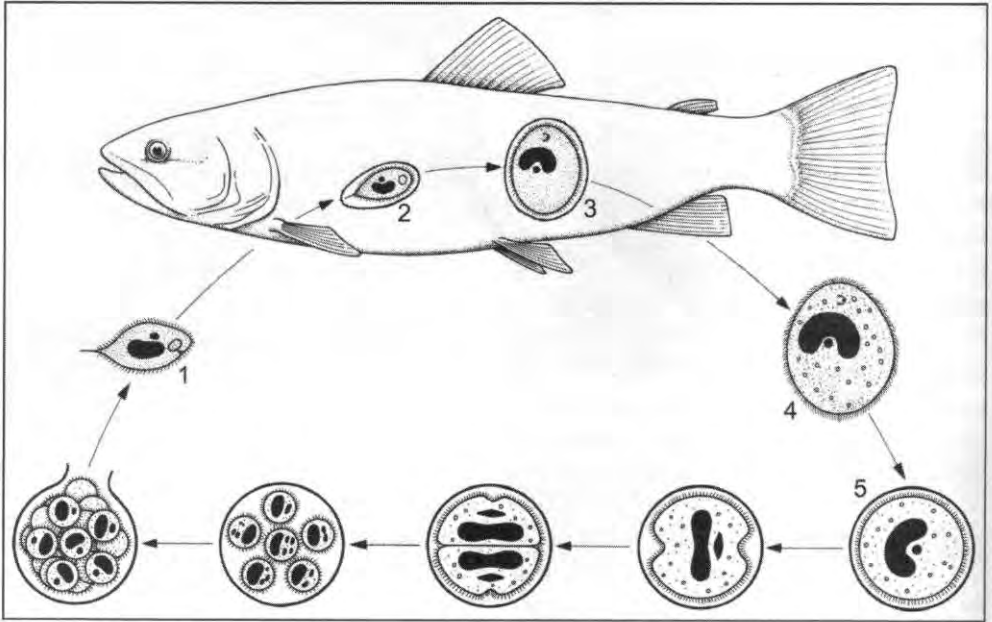

139. Oligohymenophorea:
 (), 2 —
 , 5 —
).

Ichthyophthirius multifiliis: 1 —
 , 3 — , 4 — (

Peritrichia Stein, 1859 —

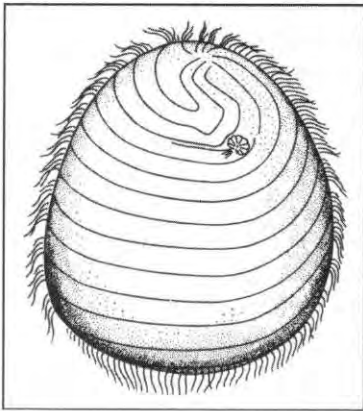

140. Oligohymenophorea:
Foettingeria (: Corliss: Trans. Amer.
 Microsc. Soc. 97 [1978] 419). : 480x.

1000
 —
 (=)
 (. 141).
 (),



Рис. 141. Oligohymenophorea:

Epistylis,

де () X. ;
Литература () . : 180 .

Sessilida Kahl, 1933

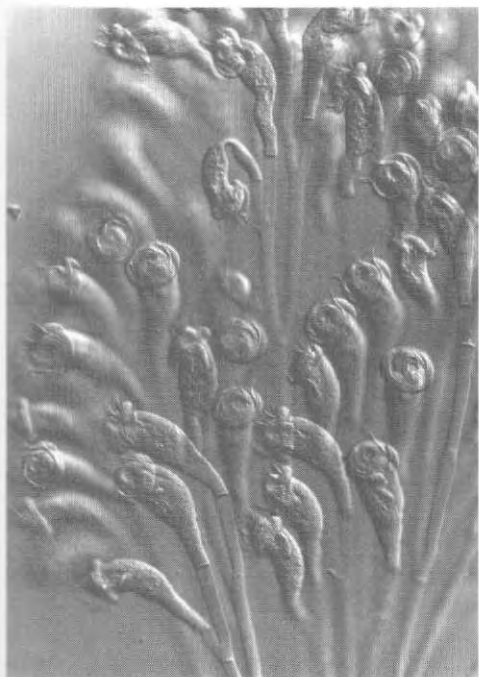
()

всту ;

кесто ;

вма ;

водо ;

зед ; *Vorticella* *Carchesium*

> (. 142),

белко ;

стро ;

при ;

рост ; (

ма ; *Epistylis*);

но ;

но ;

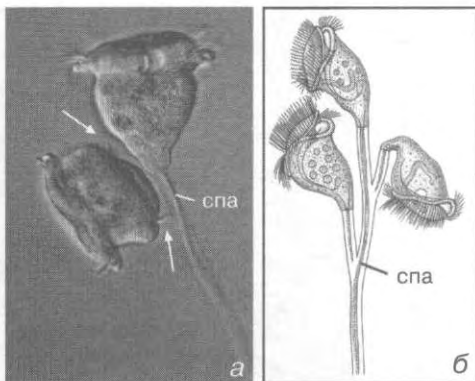

. 142. Oligohymenophorea: — *Vorticella*
; ()
, (),
, — *Carchesium*.
— (—).
— 140 .

(*Vaginicola*, *Cothurnia*)

(*Ophrydium*, . 143).

144).

()

,

;

;

;

;

;

;

;

Peritricha

;

: *Carchesium*, *Cothurnia*,

Epistylis, *Ophrydium*, *Vaginicola*,

Vorticella.

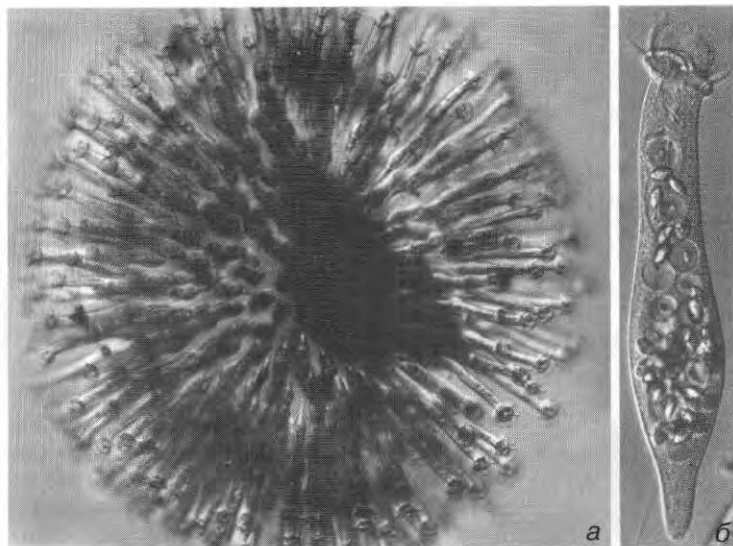

143. Oligohymenophorea: () — () *Ophrydium* (: Hausmann and Ostwald: *Mikrocosmos* 76 [1987] 129). : a — 35x, — 160x.

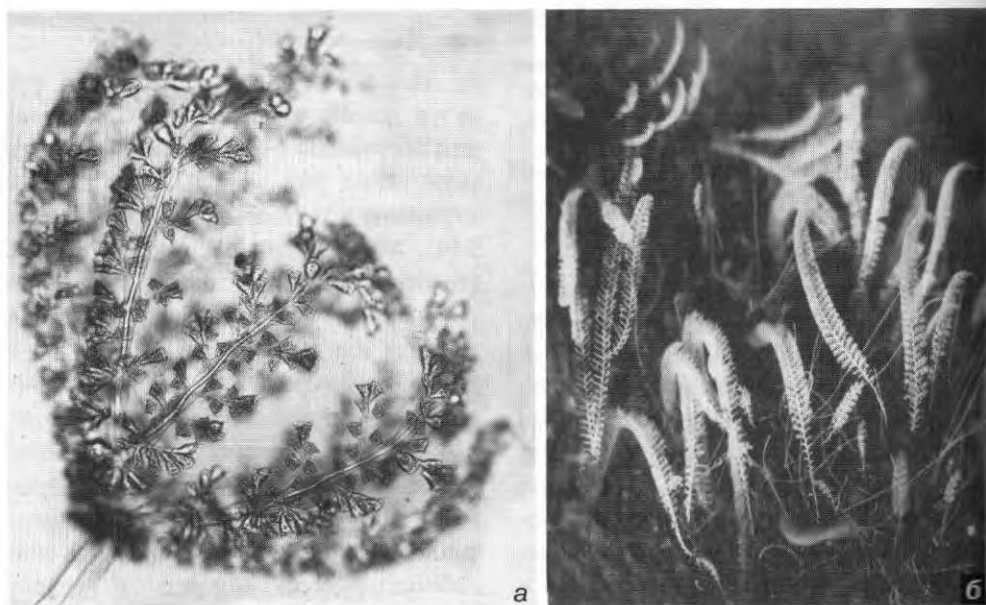

144. Oligohymenophorea: a — *Zoothamnium arbuscula*; б — *Z. niveum*, (—). : — 80 , — 4 .

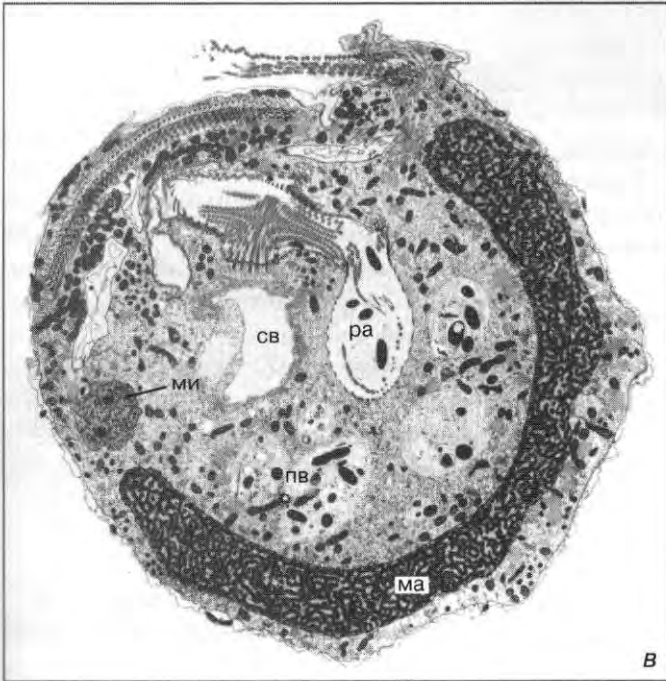
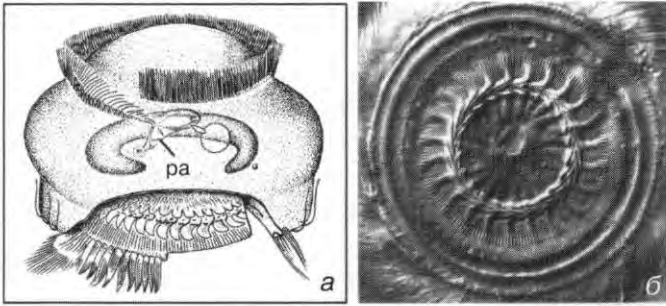

145. Oligohymenophorea: *Trichodina*. — ;
 — ;
 (—);
 — ;
 , (),
 (), (),
 () (—
) (—
 ; — :
 Hausmann and Hausmann:
 J. Ultrastruct. Res. 74 [1981]
 131). : a — 800x, —
 1 , — 2 600x.

Mobilida Kahl, 1933

Peritricha
 Mobilida.

(. 145).

Trichodina pediculus

. *pediculus*
 . *cyprinis*,

Clevelandellida de Puytorac & Grain, 1976

: *Trichodina*, *Urceolaria*.

Astomatia Schewiakoff,

1896 —

(. 146) —

Oligohymenophorea

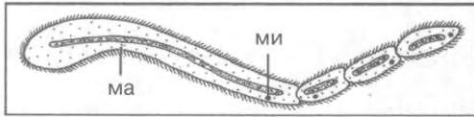

. 146. Oligohymenophorea:

Radio

phrya.

(. 75) .

: *Anoplophrya*, *Haplophrya*,
Radiophrya.

Intramacronucleata

(*sedis mutabilis*').

¹ . 158.

: *Clevelandella*, *Nyctotherus*.

Odontostomatida Sawaya,

1940

Odontostomatida

147).

8 10

. Odontostomatida

: *Discomorphella*, *Epalxella*,
Mylestoma, *Saprodinium*.

HAPLOSPORA Caulery &

Mesnil, 1889 —

Haplosporidium (. 148),

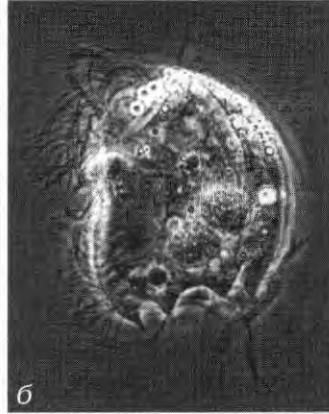
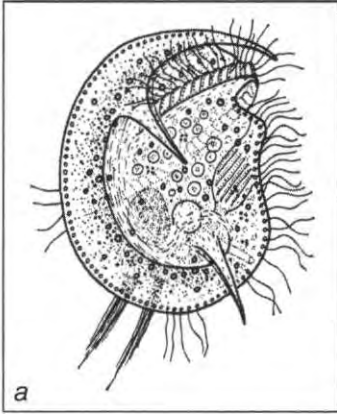

147. Oligohymenophora:
Discomorpha pectinata ()
Saprodinium putrinium ()
 (—
 ;
 —
) . ∴ —500 , —
 450 .

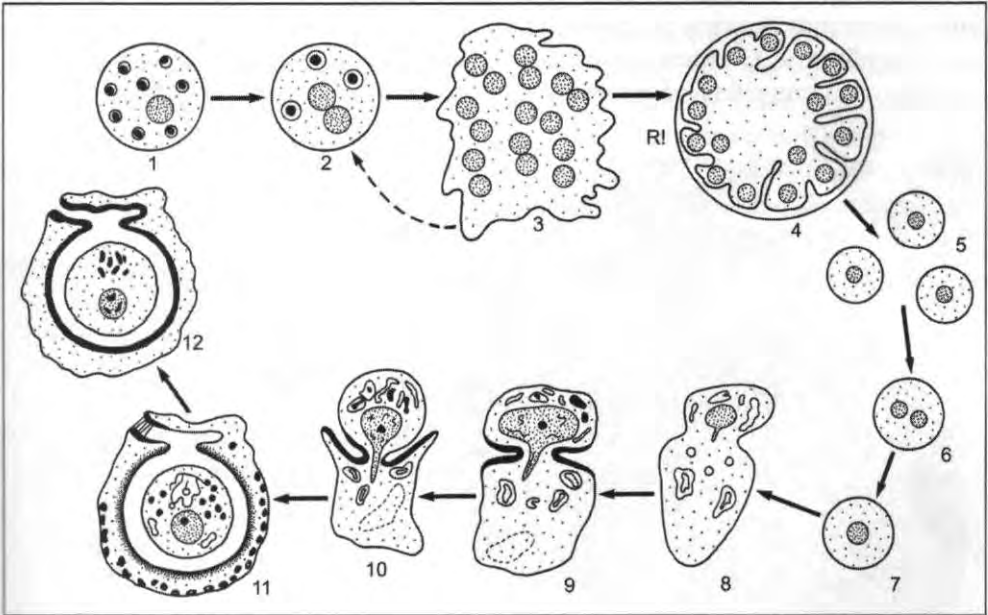
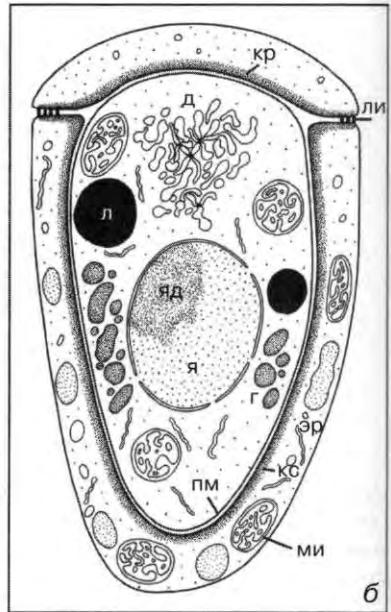
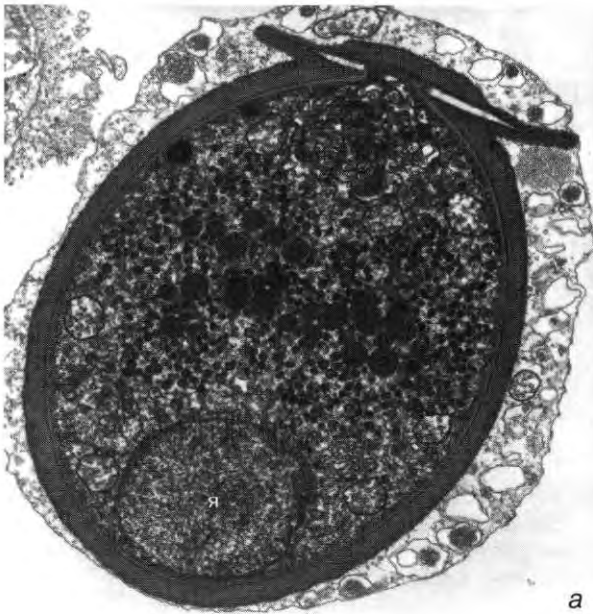

Fig. 148. Alveolata, Haplospora:

1 —
 2 —
 3 —
 4 —
 5 —
 6 —
 7 12 —

Haplosporidium. 1 —
 2 —
 3 —
 4 —
 5 —
 6 —
 7 —
 8 —
 9 —
 10 —
 11 —
 12 —
 R! — () .

1981 ;
 1982 ;
 1983 ;
 1984 ;
 1985 ;
 1986 ;
 1987 ;
 1988 ;
 1989 ;
 1990 ;
 1991 ;
 1992 ;
 1993 ;
 1994 ;
 1995 ;
 1996 ;
 1997 ;
 1998 ;
 1999 ;
 2000 ;
 2001 ;
 2002 ;
 2003 ;
 2004 ;
 2005 ;
 2006 ;
 2007 ;
 2008 ;
 2009 ;
 2010 ;
 2011 ;
 2012 ;
 2013 ;
 2014 ;
 2015 ;
 2016 ;
 2017 ;
 2018 ;
 2019 ;
 2020 ;
 2021 ;
 2022 ;
 2023 ;
 2024 ;
 2025 ;



149. Haplospora: —
); —

Minchinia louisiana (—
Minchinia nelsoni. —

). : — 11,000 .

Haplo-

spora

Alveolata.

(. 149).

: *Haplosporidium*, *Minchinia*, *Urosporidium*.

CERCOZOA Cavalier Smith,

1998

70

250

Rhizopoda *sensu*

von Siebold, 1845

(Heterokonta)

(,),

(. . 181).

: *Phytomyxa*, *Reticulofilosa*
Monadofilosa.

PHYTOMYXA Cavalier

Smith, 1998 (Plasmodiophorea) —

Haplosporidium

Haplospora

Paramyxea

Cercozoa,

Ascetospora.

Reticulofilosa *Monadofilosa*.

: *Plasmodiophora*, *Sorosphaera*, *Spongospora*, *Tetramyxa*.

RETICULOFILOSA

Cavalier Smith, 1998
(Chlorarachnida) —

Monodofilosa.

(*Reticulosphae*

(. 150).

).

(. 151).

(,)

1

Plasmodiophora brassica

4 8

(

).

(

).

(

)

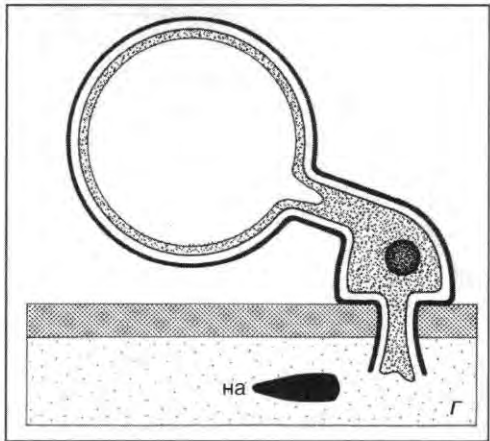
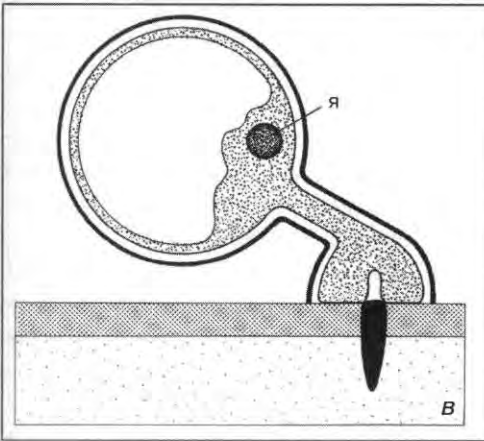
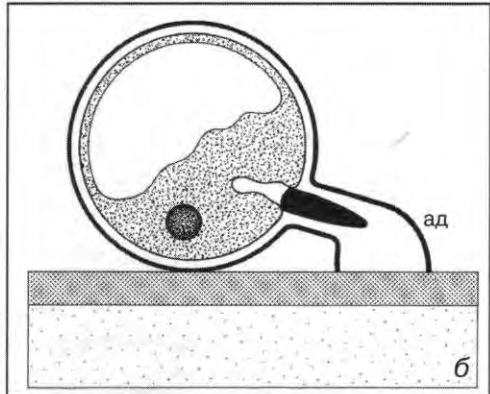
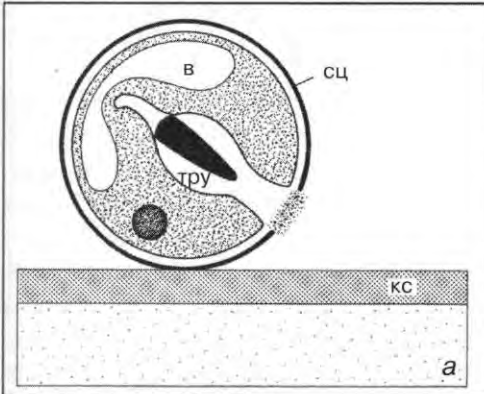

150. Cercozoa, Phytomyxa:

Plasmodiophora

(). — , — , — ()

Chlorarachnion reptans *Lotharella amoebiformis*.

() — .
 () —
 () —
 () —

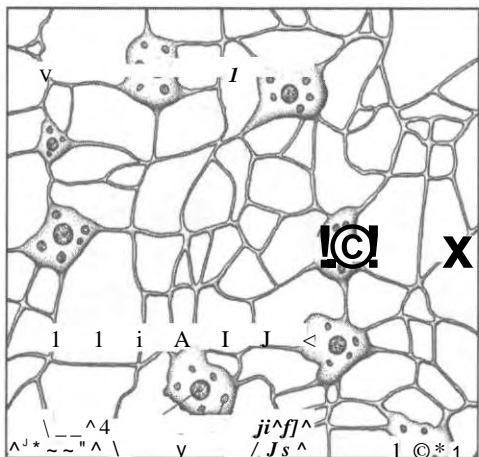

. 151. Cercozoa, Reticulofilosa:
Chlorarachnion:

() () . : 1 500 .

: Chlorarachnion, Lotharella, Gymnochlora.

MONADOFILOSA

Cavalier Smith, 1998

Gromiida)
1879 (

Filosea Leidy,

zoa),

Fungi/Meta

(Lecythium),
(Pseudodiffugia)
(Euglypha, . 152).

Paulinella chromatophora

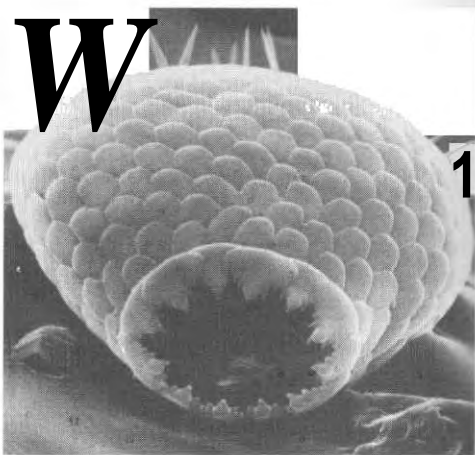

. 152. Cercozoa, Monadofilosa:
Euglypha (

). : 980 .

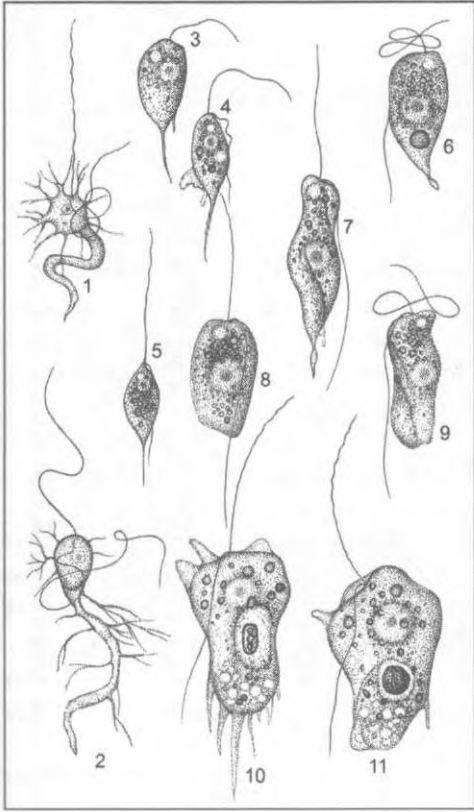

153. Monadofilosa:
 1 2 — *Cercobodo**
draco ;
 3 5 — *varians*; 6 9 — *norrvicensis*; 10
 11 — *pyriformis* (). : 1 11 —
 1

(Sarcomonadea)

Cryothecomonas,

Thaumatomonas ()
Cercomonas ()

Cercobodo

Cercomonas. —

0,035 0,040

).
 (. 153).
 : *Cyphoderia*, *Euglypha*,
Lecythium, *Paulinella*, *Pseudodiffugia*,
Trinema (); *Cerco-*
monas, *Cryothecomonas*, *Thaumatomonas*
 ().

FORAMINIFERA d'Orbigny,
 1828 (Granuloreticulosa) —

Cercozoa

<1 (. 154).²

(. 22 , 23

10) —

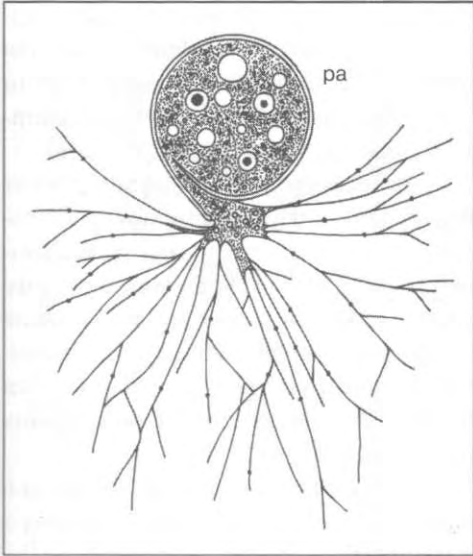

Reticulomyxa (. 154)

Allogromiida,

(*Lieberkuhnia*,

Microgromia)

nifera:

Forami-

. 155. Foraminifera: *Lieberkuhnia*.
pa — (). .: 220 .

1

36

Granuloreticulosa *sensu* de Saedeleer -

4000

50

: *Athalamea* (),

thalamea (

, . 155) *Foraminifera* (

20

).

(*Biomy*

, *Pontomyxa*, *Reticulomyxa*)

(),

lomyxa filosa,

Reticu-

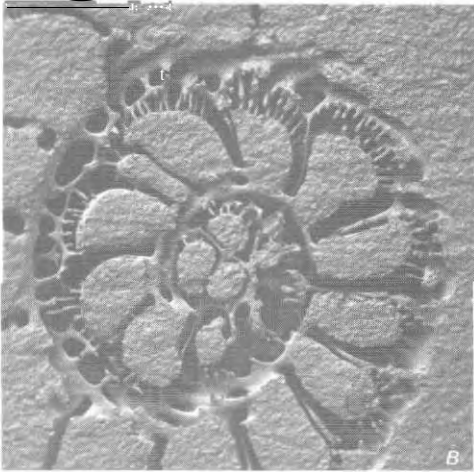
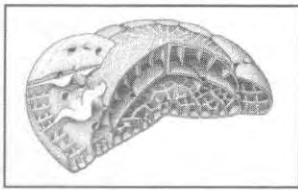

156. **Foraminifera:** —
 Sorites; —
 Orbitolina; —
Parrellina hispidula (—
 ; — : **Hottinger:**
Schweizerische Palaont. Abh. 101 [1980] 115).
 .: — 20 , — , — 140 .

Foraminifera

- Allogromiida (

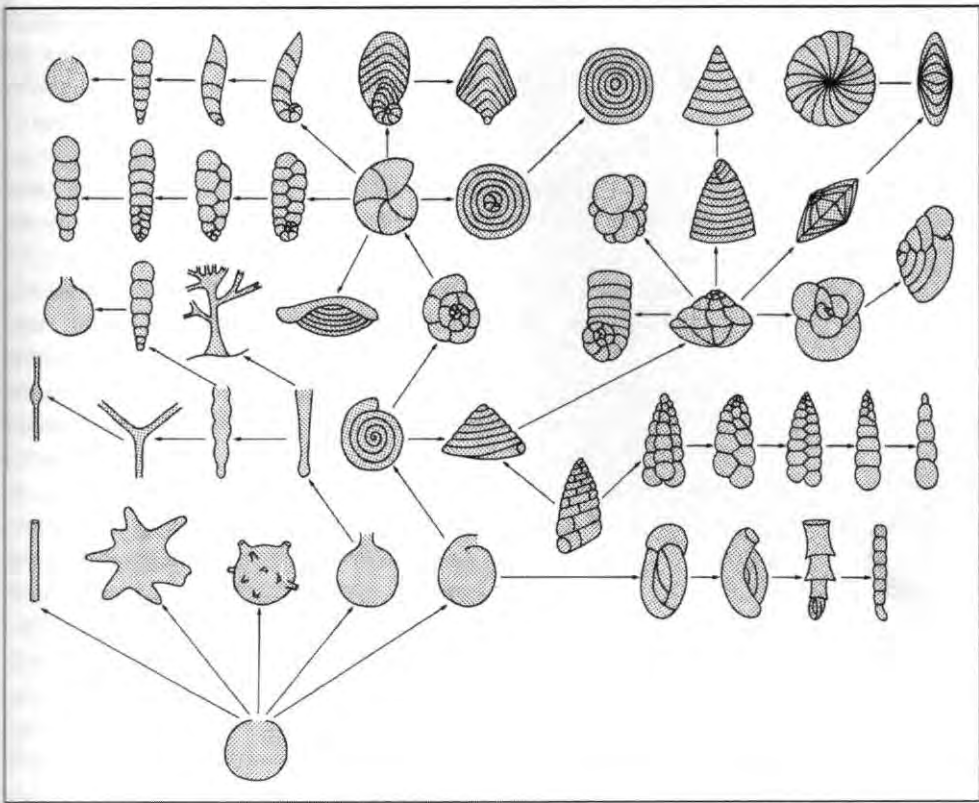

157. Foraminifera:

().

- Textulariida ().

Xenophyophorea (

).

- Fusulinida (

).

- Rotaliida (

- Miliolida (

tularia Allogromiida)

Miliolida),

(Rotaliida

158):

(. 157,

2 3),

(

;

),

(

),

(

(. 157).

144°

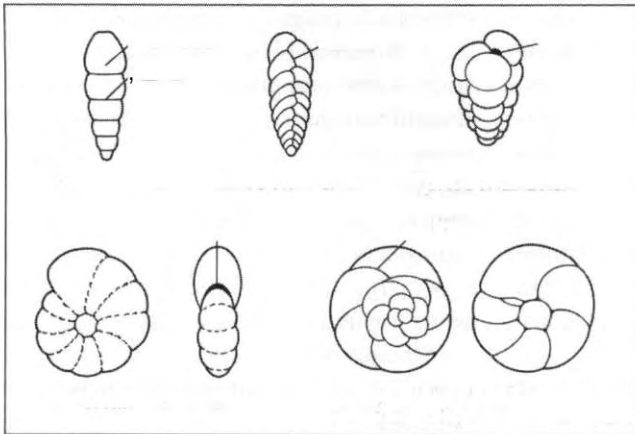

. 158. Foraminifera:

(. 157).

(), ()

(. 159)

(. 160).

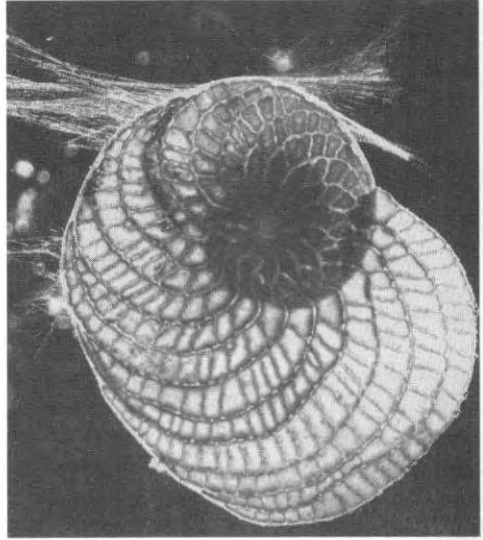

159. Foraminifera: *Heterostegina depressa*

: 5 .

3000

(. 160)

— *Gymnodinium beii*
Symbiodinium

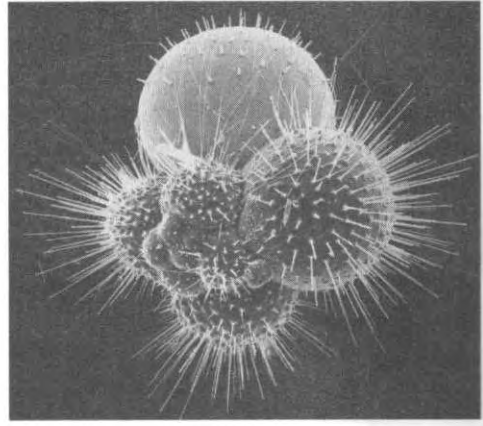

160. Foraminifera: *Globigerina bulloides*

() . : 170 .

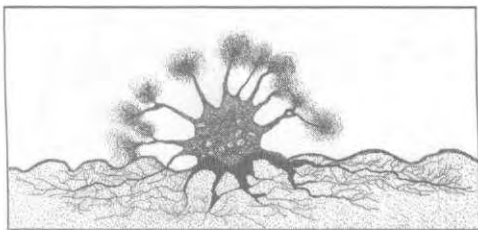

161. Foraminifera: *Astrorhiza limicola*

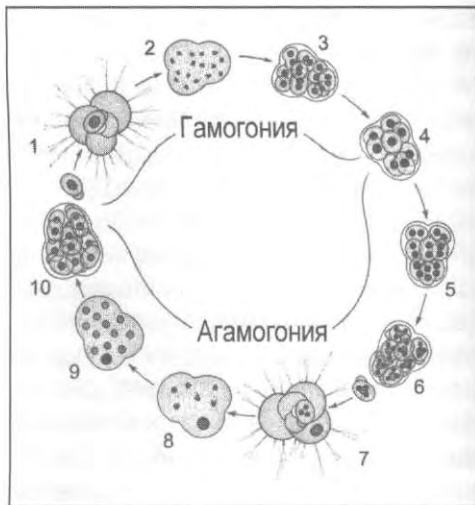

162. Foraminifera:

Rotaliella

heterokaryotica.

- 1 —
- 2 —
- 3 —
- 4 —
- 5 —
- 6 —
- 7 —
- 8 —
- 9 —
- 10 —

(. 161).

: *Allogromia*, *Globigerina*, *Hastigerina*, *Heterostegina*, *Lieberkuhnia*, *Orbitolina*, *Reticulomyxa*, *Rotaliella*, *Schwagerina*, *Textularia*, *Triloculina*.

162) —

BILIPHYTE Cavalier Smith,
1981

Rhodophyta Glaucocestophyta.

RHODOPHYTA Wettstein,

1901 —

6000

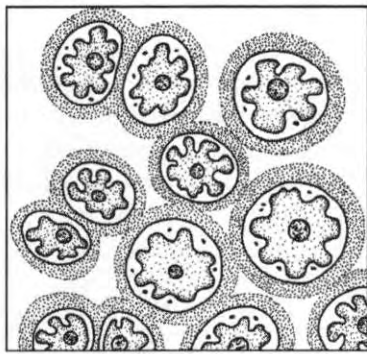

163. Biliphyta, Rhodophyta:
Porphyridium omentum,
 (

.) : 550 .

: (1)

; (2)

; (3)

; (5)

(. 163),

1'

(.)

(, ,

),

Rhodophyta

Apicomplexa ,
Alveolata,

: *Porphyridium* (
).

GLAUCOCYSTOPHYTA

Kies & Kremer, 1986 —

Alveolata,

Viridiplantae (= Chloro
bionta,)

13 (4)

Cyanophora

doxa

()

Glaucocystis

G. nosto

chinearum (. 164)

Trachelomonas (Euglenida).

(

).

(

)

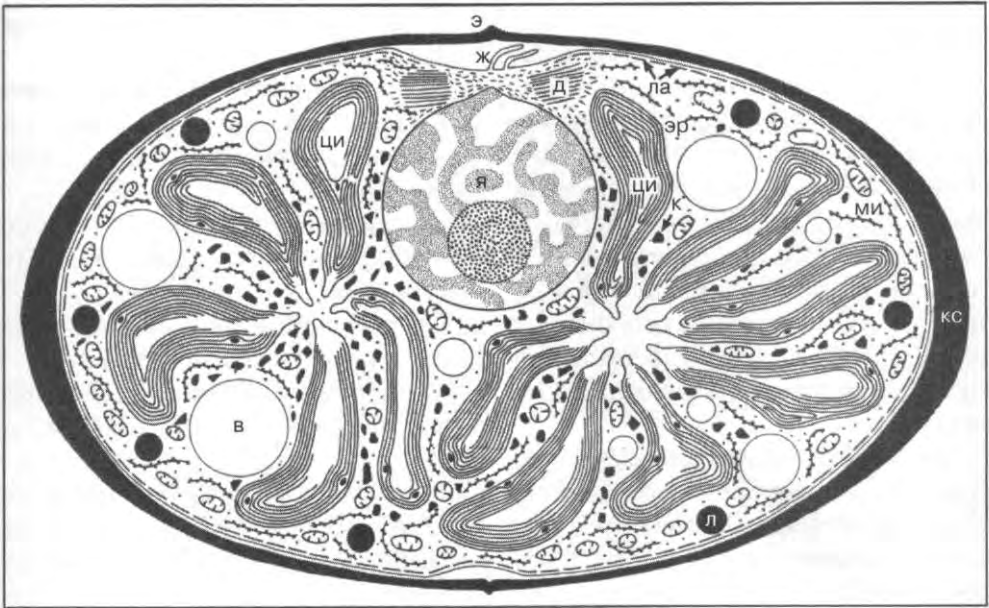

164. Biliphyta, Glaucocystophyta: *Glaucocystis nostochinearum*.

(),
 (=)
 : 5

(Embryophyta),

PaulineUa chromatophora,

Gymnodinium Massar

8000

tia,

250

: *Cyanophora*, *Cyanoptycha*,

Gloeochaete, *Glaucocystis*.

VIRIDIPLANTAE Cavalier Smith,

1981 (Chlorobionta) —

(),

()

;

;

stigma ()

;



()

Meso ()

()

;

(1)

(2)

(249)

()

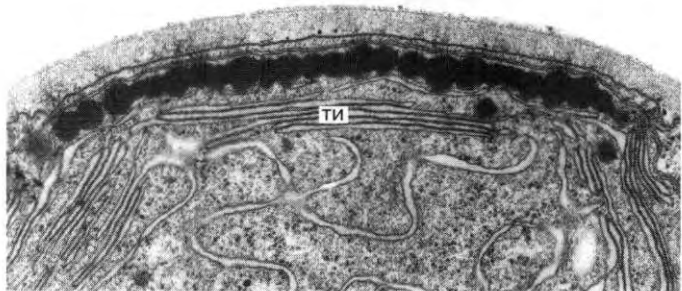

165. Viridiplantae: Chlorogonium

14.

Viridiplantae.

()

() ; Chlorophyta

(. 166)

14

CHLOROPHYTA
Pascher, 1914

Chlorophyta

() ,

(Ulvophyceae, Trebouxiophyceae, Chlorophyceae).

— 50) ,

(40

(. 166).

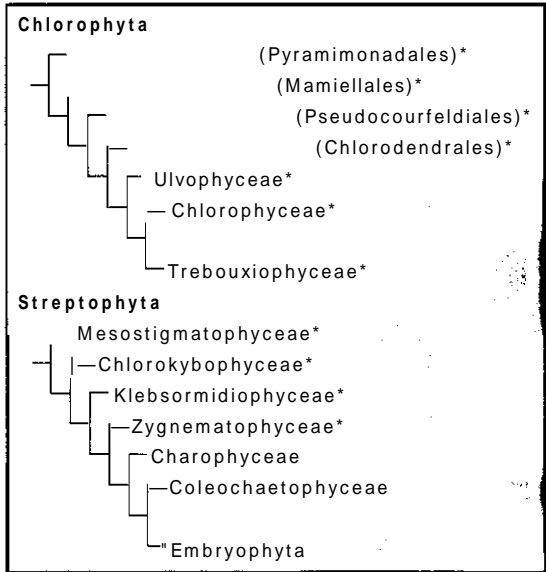

14,
t&pusyATI

В отличие от Volvocida, многоклеточные

Prasinomo

nadea

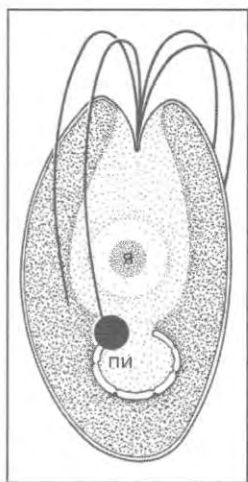

167. Viridiplantae, Chlorophyta, *Tetraselmis bichlora*.
 1600
 1 16,
 4 (. 167).

Tetraselmis,

().

Pyramimonadales

Katablepharis (. .

62).

{*Tetraselmis convolutae*

= *Platymonas convolutae*)

Convoluta roscoffensis,

: *Pyramimonas*,

monas (Pyramimonadales), *Mamiella*,
 (Mamiellales), *Nephroselmis*, *Pseudo*

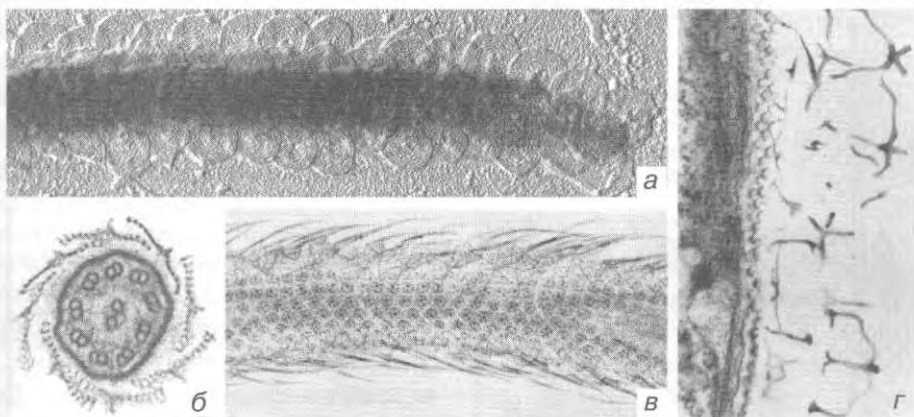

168. Chlorophyta, (), — *Mantiella squamata*; — *Mamiella gilva*; , — *Pyramimonas tetrahynechus* (. . 47 , — 68 , —

scourfeldia (Pseudoscourfeldiales), *Tetra-selmis* (Chlorodendrales), *Prasinomonas*.

ULVOPHYCEAE Mattox & Stewart, 1984 —

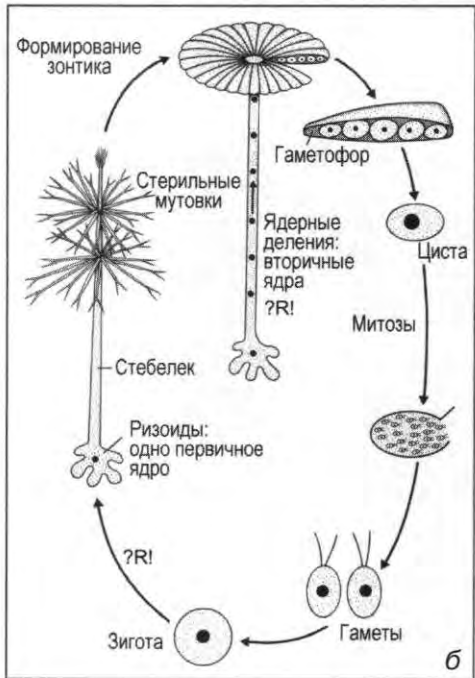
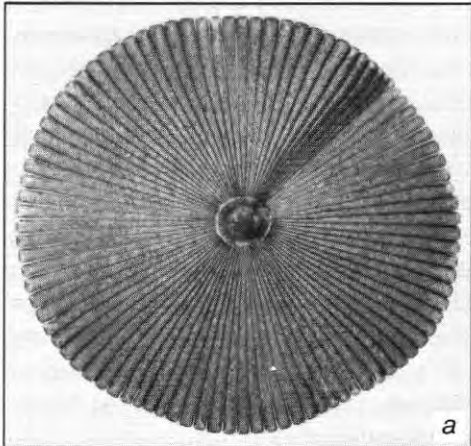

(*Ascosiphonia*, *Cladophora*, *Derbesia*, *Ulothrix*)

(*Ulva*, *Caulerpa*, *Halimeda*).

(*Dasycladales*).

(. . . 166).

Dasycladales

(. . .)

(. . . 169).

— *Acetabularia acetabulum* —

: *Acetabularia*, *Dasycladus*.

TREBOUXIOPHYCEAE Friedl,

1995 —

. 169. Chlorophyta, Ulvophyceae: *Acetabularia*: — —

(. . .). . . . — 8 .

Trebouxiophyceae —

(. 170).

Chlorella (*cium bursaria*)

Chlorella)

Trebouxia —

. 170. Chlorophyta:

: 1 — *Trochiscia*, 2 — *Chlorella*,
 3 — *Palmellococcus*, 4 — *Chlamydomonas*
 (), 5 —
Radiosphaera, 6 — *Chlorococcum*, 7 — *Neo*
chloris, 8 — *Trebouxia*, 9 — *Spongiochloris*,
 10 — *Myrmecea*, 11 — *Dictyochloropsis*, 12 —
Macrochloris, 13 — *Bracteacoccus*, 14 —
Scotiellopsis, 15 — *Pseudococcomyxa*, 16 —
Coccomyxa, 17 — *Choriocystis* (: Kremer:
Mikrokosmos 87 [1998] 25). : 1 11
 15 17—1 , 12 —350x, 13 14—550x.

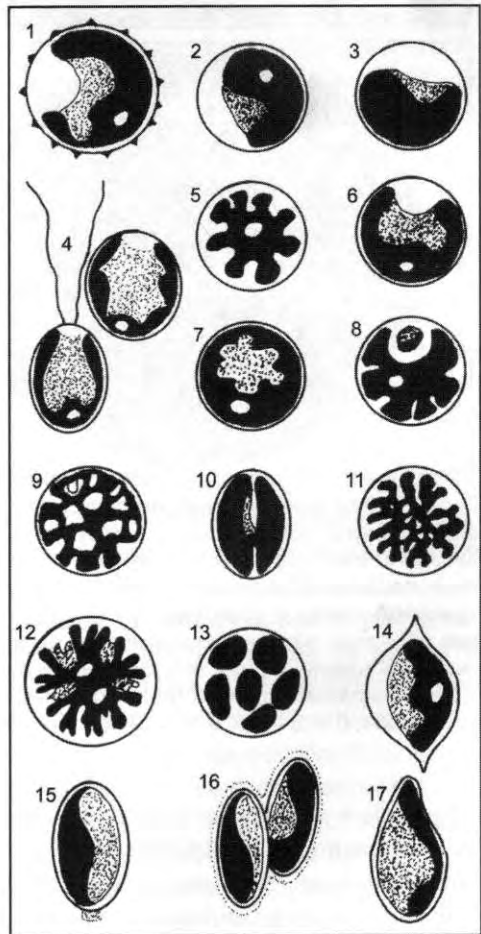

1912 *Heli*

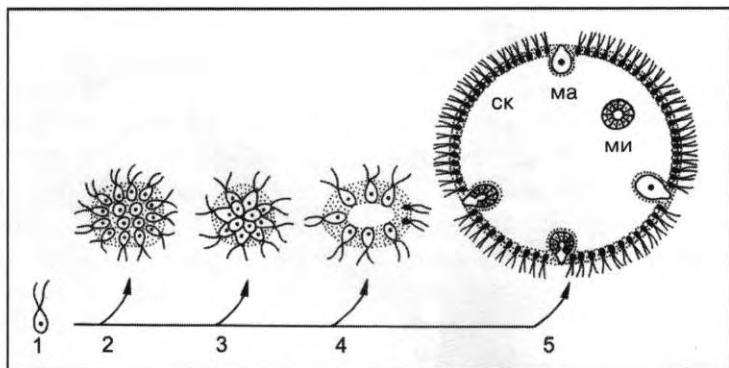

172. Chlorophyta, Chlorophyceae:
 monas (1), Gonium (2), Pandorina (3), Eudorina (4),
 Volvox (5), Eudorina, Volvox

Chlamydo-

()

Volvocida France, 1894

(Volvocales) —

Volvocida —

Polytoma, Hyalogramonium,

()

: Chlamydomonas, Chlorogonium, Dunaliella, Pandorina, Volvox.

Chlorococcales Marchand,

1895 —

(Chlamydomonas, Chlorogonium),

1000

: Goni-

um, Eudorina, Pleodorina, Volvox (172).

(

).

Chlamydomonas

: *Chlorococcum*, *Pediastrum*, *Scenedesmus*.

STREPTOPHYTA Jeffrey,

1982

(Charales, Coleochaetales Embryophyta),

(Mesostigmatales, Chlo- rokybophyceae, Klebsormidiophyceae Conjugatophyceae)

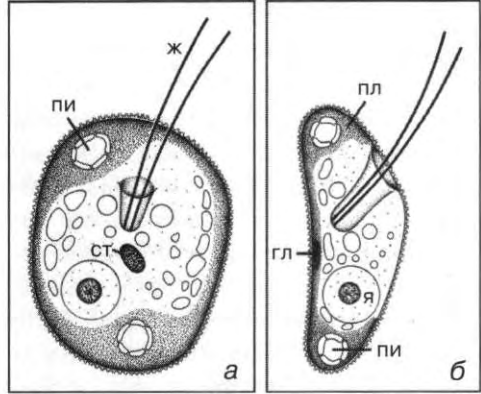

173. Viridiplantae, Streptophyta, Meso- stigmatophyceae: *Mesostig- viride*: () (), — () .

2 200 .

MESOSTIGMATOPHYCEAE
Marin & Melkonian, 1999

(. 173),

KLEBSORMIDIOPHYCEAE

van den Hoek et al., 1995

Klebsormidiophyceae

15

Klebsormidium

: *Mesostigma* (
) , *Chaetosphaeridium* (
).

CHLOROKYBOPHYCEAE

Bremer, 1985

Chlorokybophyceae

: *Klebsormidium* (
) , *Raphidonema*, *Stichococcus*.

CONJUGATOPHYCEAE

Engler, 1892 (Zygnematophyceae) —

: *Chlorokybus atmos*
phyticus.

Amoebozoa,

Lobosa Conosa.

LOBOSA Carpenter,

1861 —

Conjugatophyceae

. 174.

: *Closterium*, *Micrasterias*.

AMOEBOZOA Luhe, 1913

Acarpomyxea

(

).

Amebozoa

Cercozoa Schizopyrenidea.

Multicilia

Conosa.

Conjugatophyceae

(Gymnamoebia, Acarn)
(Testacealobosea).

GYMNAMOEBEA Haeckel,

1862

(. 175).

(. 176)

(*Vannella*, . . 8).

(, (Gymnamoebia)).

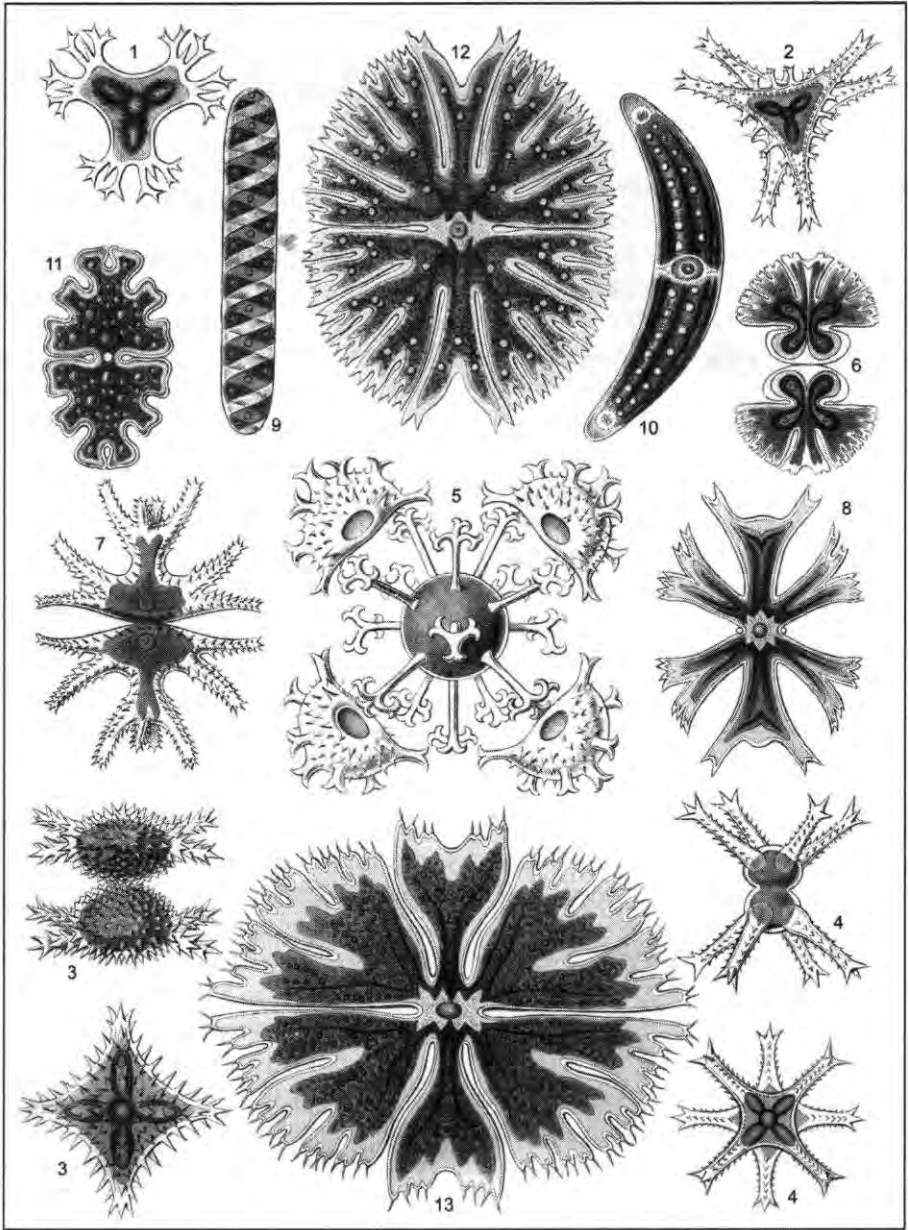

174. Streptophyta, Conjugatophyceae:

: 1 — *Staurastrum furcatum*, 2 — *S. vestitum*, 3 — *S. aculeatum*, 4 — *S. paradoxum*, 5 — *S. spinosum*, 6 — *Micrasterias denticulata*, 7 — *M. trigemina*, 8 — *M. melitensis*, 9 — *Spirotaenia condensata*, 10 — *Closterium costatum*, 11 — *Euastrum pecten*, 12 — *E. agalma*, 13 — *E. apiculatum* (: Haeckel: *Kunstformen der Natur*. Verlag des Bibliographischen Instituts, Leipzig 1899 1904).

. 175. Amoebozoa,
Lobosa, Gymnamoebia:
Amoeba proteus:

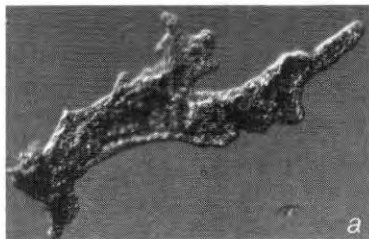

()
()
: — 180 .

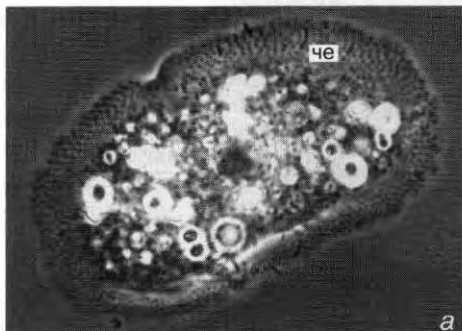

. 176. Gymnamoebia
() Testacealobosea
() : — *Cochliopodidum*,

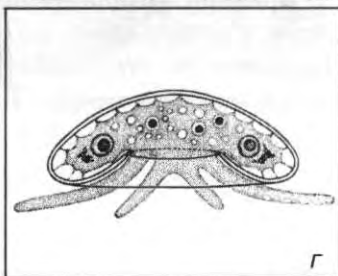
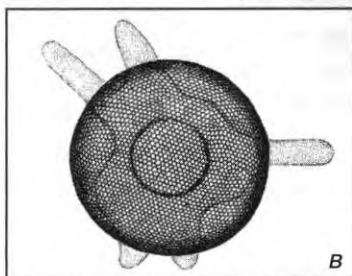

() ; —
Diffugia; , —
Arcella vulgaris,
() ()
(—
, ; —
) . : — 800 ,
— 450 , — 220 .

nense.

(. . 259),

(. . 26).

(*Acanthamoeba*).

Multicilia

Amoeba proteus.

Vannella , *Hartmannella*,
Chaos caroli

Acanthamoeba.

TESTACEALOBOSEA de Seadeleer, 1934 —

Acanthamoeba,
Acanthamoeba castellanii, *A. culbertsoni* *A. polyphaga*

Cochliopodium (. 176)

Acanthamoeba,
Acanthamoeba

(. . 221).

: *Acanthamoeba*, *Amoeba*, *Chaos*, *Cochliopodium*, *Dactylamoeba*, *Hartmannella*, *Mayorella*, *Multicilia*, *Saccamoeba*, *Thecamoeba*, *Vannella*.

(. 1765, . . 32 ,)

ACARPOMYXEA Page, 1976

(. 176 ,

).

: *Arcella*, *Diffugia*, *Hyalosphenia*, *Nebela*.

(. . 23, 9).

CONOSA Cavalier Smith,

1998

: *Corallomyxa*, *Leptomyxa*,
Stereomyxa.

Conosa

Информация
ARCHAMOEBA
 Cavalier Smith, 1983

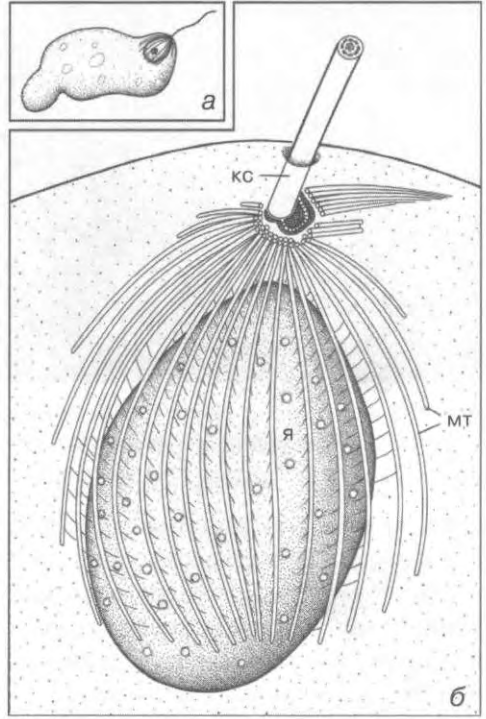

177. Amoebozoa, Conosa, Archamoeba:
Mastigina (),

(. 177).

() () (), —
 () . ∴ — 250 , —
 12 .

Pelomyxa

palustris (. 178),

2 ,

Rhizopoda Pelobiontida
 Page, 1976.

XIX ,

1 5 .

(. 259).

Mastigella Pelomyxa. —
 9x2+2

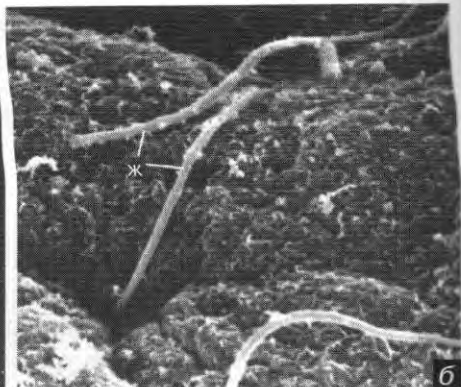
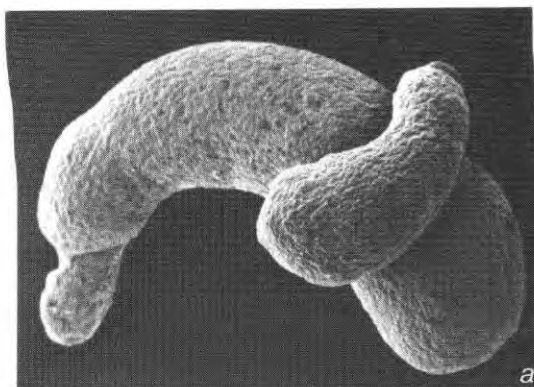

178. Archamoeba:

Pelomyxa palustris () () ()

: — 100 , 6 — 8 .

Mastigina.

Mastigella Mastigamoeba

Entamoeba histolyti-

ca. —

Enta-

moeba.

: *Entamoeba, Mastigella, Mastigina, Pelomyxa, Mastigamoeba (= Phreatamoeba).*

MYCETOZOA de

1859

Acrasea,

4

(Protostelea,

Myxogastrea Dictyostela)

(Aconchulina).

Acarpomyxea

: *Cavostelium*, *Ceratiomyxa*,
Protostelium.

MYXOGASTREA Olive, 1970 —

EUMYXA Cavalier Smith,

1998

Eumyxa

: Protostelea Myxogastrea,

1

(. . . 28),

PROTOSTELEA Olive, 1970 —

(12) (. . 179).

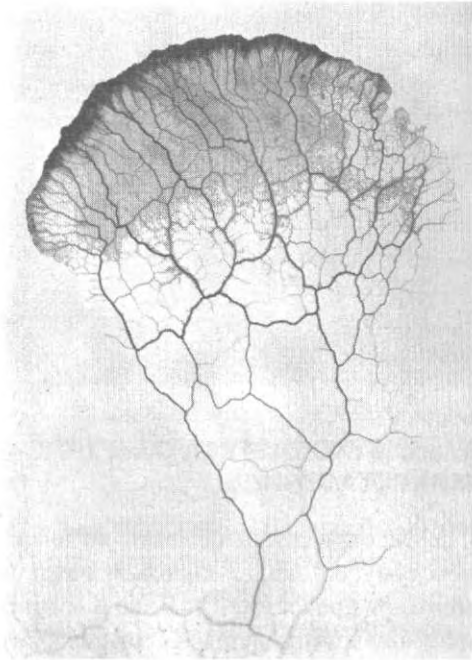

. 179. Conosa, Mycetozoa, Myxogastrea:
Physarum confertum (:
Stiemerling: Cytobiologie 1 [1970] 399). — :
2x.

: *Echinostelium*, *Physarum*.

Trichia.

DICTIOSTELA Olive,

1970 —

(. 180, 316).

(. 180).

(,).

1

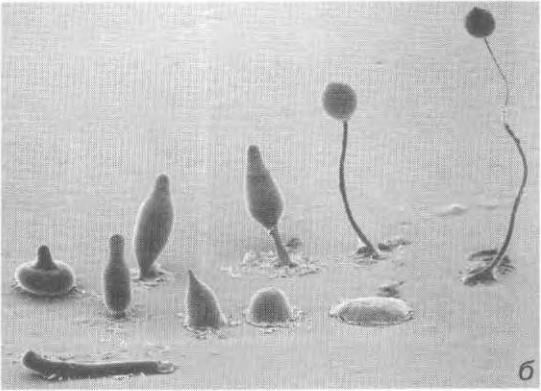
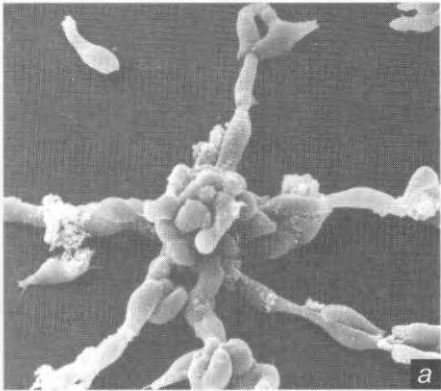

180. Mycetozoa, Dictyostela: — *Dictyostelium* (— 620, — 40)

Gromiida

Lobosa (Gymnamoebae, Acarpomyxea, Testacealobosea)

6

Aconchulina

: *Acytostelium*, *Dictyostelium*, *Polysphondylium*.

ACONCHULINA

de Saedeleer, 1934

chulinida)

Gromiida.

Cercozoa.

Aconchulina

Vampyrellidae,

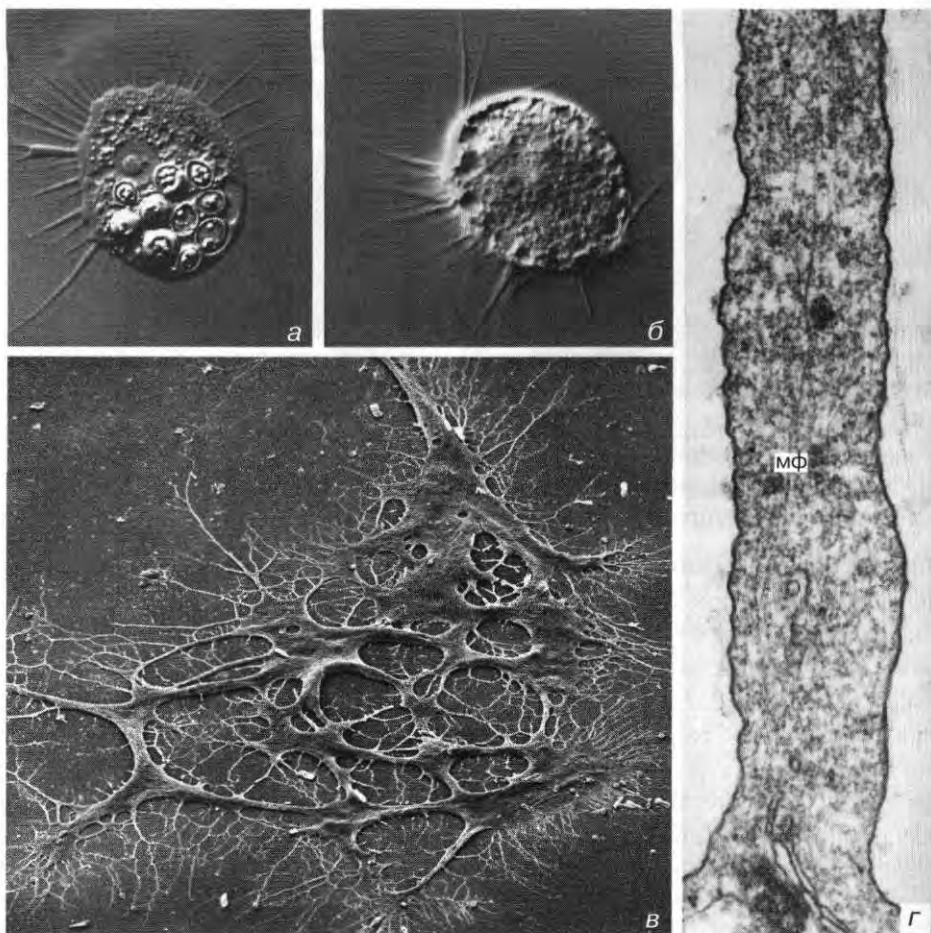

181. Mycetozoa, Aconchulina: — *Nuclearia*; — *Lateromyxa*
 — *Thalassomyxa australis*; — *Vampyrella lateritia*
 ; — : N. Hülsmann: J. Eukaryot. Microbiol. 40 [1993] 141; — : Grell: Protisto-
 logica 21 [1985] 215). : a — 500x, — 800x, — 160x, — 37

Aconchulina

ОПИСТОКОНТА Cavalier
 Smith & Chao, 1995 —

- : *Arachnula*, *Gobiella*,
- Hyalodiscus*, *Lateromyxa*, *Nuclearia*,
- Thalassomyxa*, *Vampyrella*.

15.

(), ().

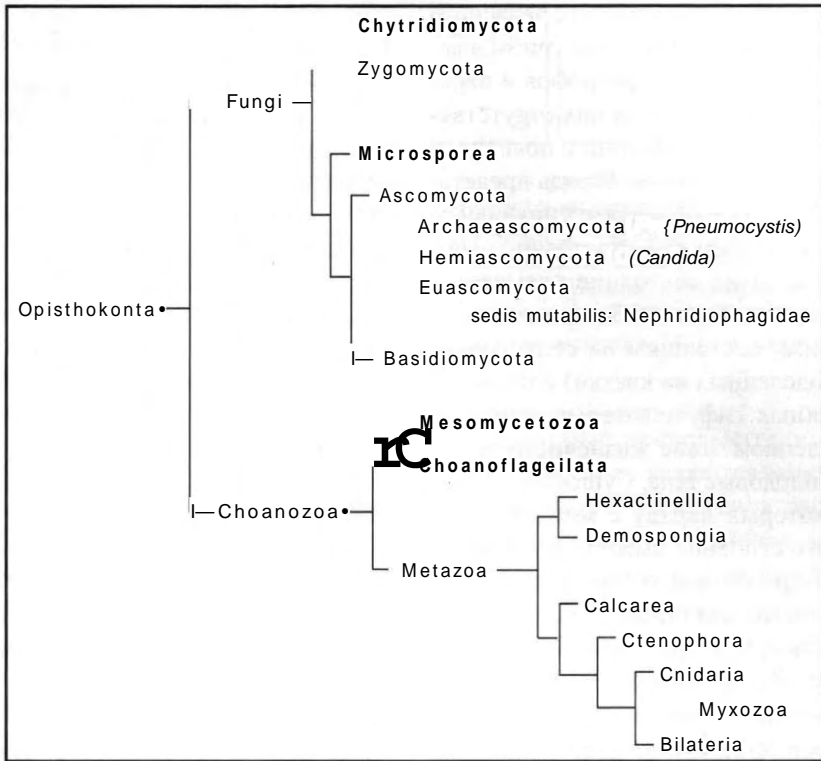

FUNGI Nees, 1817 —

Animalia, Fungi, 100, 100
 (Mesomycetozoa,
 Nephridiophagidae), 10
 Chytridiomycota (), Zygomycota () Eumycota (Micro
 (. 15).

spora, Ascomycota Basidiomycota)¹.

Fungi

:

;

()

;

Opisthokonta.

Chytridiomycetes 5

Chytridiales

),

1

(. 182).

(. .

CHYTRIDIOMYCOTA

de , 1863 —

(*Polyphagus*);

900

Aconchulina. Chytridiales

¹ 2007

(Hibbett

et al., 2007. A higher level phylogenetic classification of the Fungi. *Mycol. Res.* 111 (5): 509-547). —

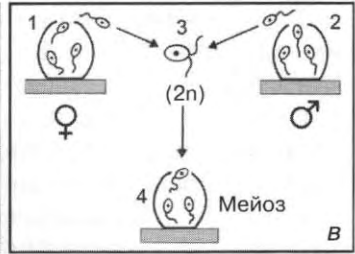
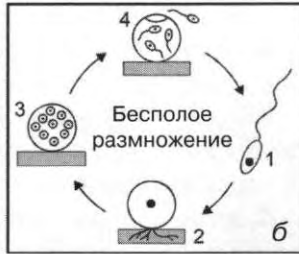
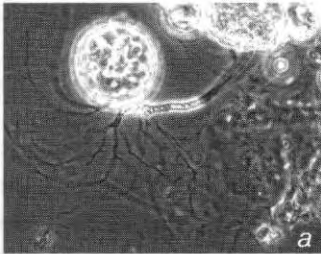

182. Opisthokonta, Fungi, Chytridiomycota: —
 ; — ; 1 — , 2 — , 3 — , 4 —
 ; — (1) (2)
 (3); (4) (—
) . ∴ — 2 .

Chytridiomycota.

Spizellomycetales

1.

Olpidium,

Rhizophydium

sphaerotheca,

: *Neocallimastix*, *Olpidium*,
Piromyces, *Polyphagus*, *Sphaeromonas*.

Chytridiomycota

Chytri-

ZYGOMYCOTA Barr,

1982 —

Xeocallimastix frontalis,

1000

0₂ 2.

Chytridiales.

Spizellomycetales

Neocallimastigales. —

), (« — 1200
 » — 144
). (Apicomplexa, Ciliophora),
 (

Zygomycota : Zygomycetes Trichomycetes.

EUMYCOTA Cavalier Smith, 1998 (Dikaryomycota) —

Microsporea

Eumycota — (), () 70S
 Microsporea. (16S 23 S),

Sporozoa

MICROSPORA Sprague, 1982

Microsporea.

MICROSPOREA Sprague, 1982 —

1
 20

. 183. Fungi, Eumycota,
Microspora: —

Pleistophora hypheobryconis

()

(), —

— (— : Lorn and
Corliss: J. Protozool. 14
[1967] 141). : 16

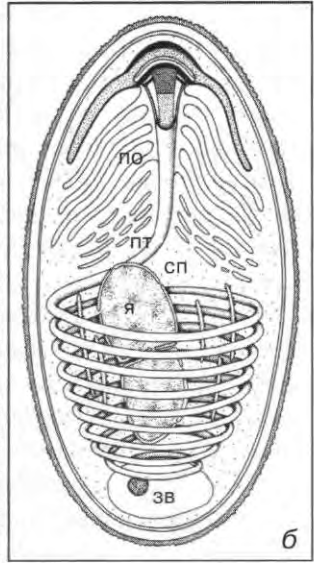
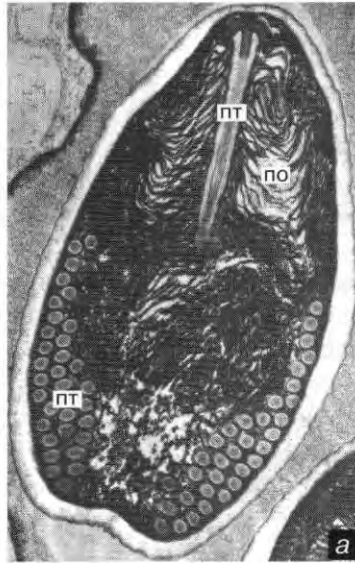

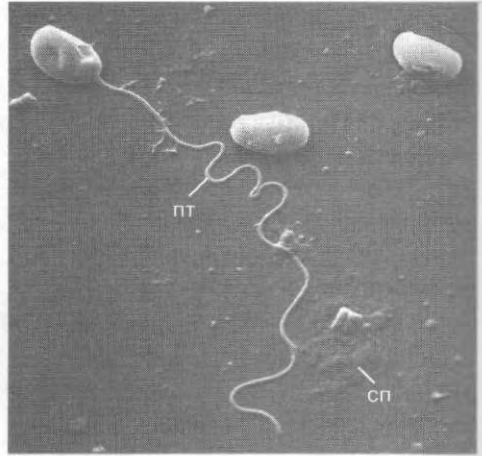

184. Microspore: () *Nosema tractabile* (: Larsson: Protistologica 17 [1981] 511). : 2900 .

vivo

in

() () 5 30

(. 184).

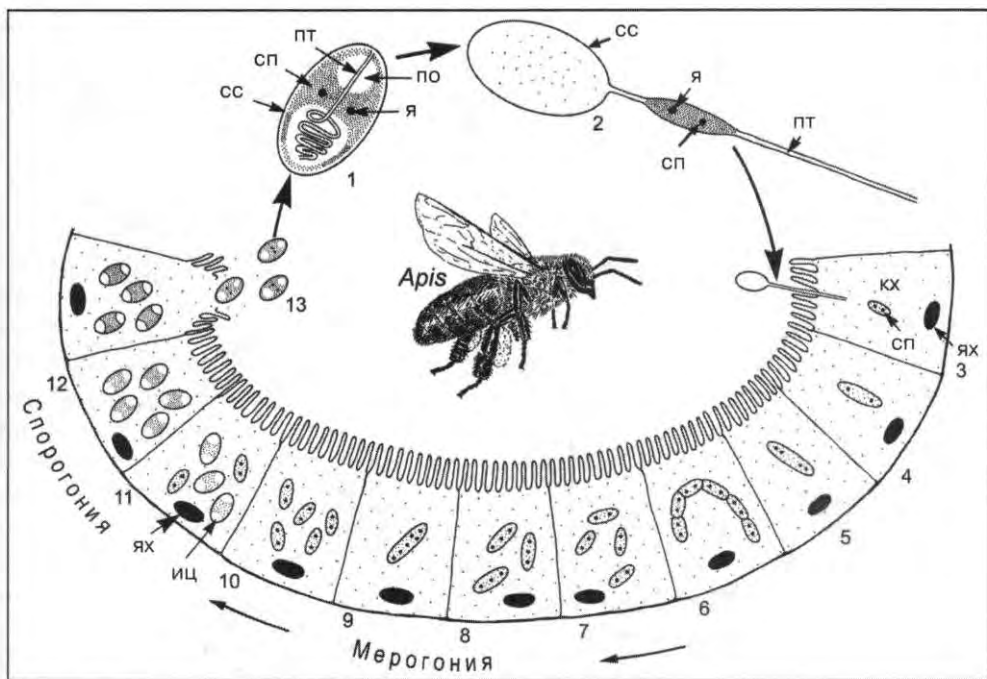

185. Microspore:

Nosema apis,

(). 1 —

. 2, 3 —

. 4 10 —

. 11 12 —

(10),

. 13 —

(. 185).

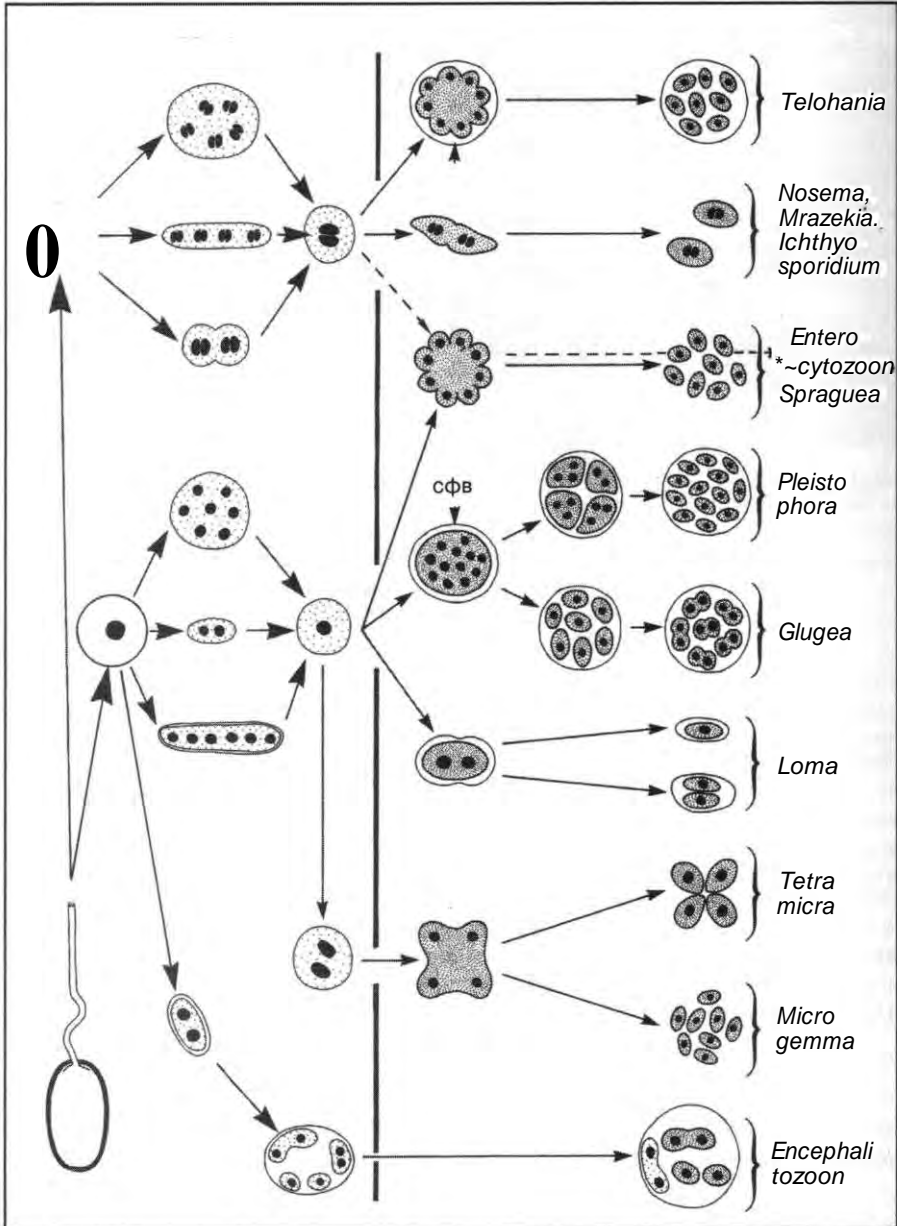

186. Microspora:

Encephalitozoon

() ()

)
 : *Amphiacantha*, *Desportesia*, *Metchnikovella*.

Microsporia Delphy, 1963

Microsporea sensu stricto,
 ()

: *Amblyostoma*, *Encephalitozoon*, *Enterocytozoon*, *Glugea*, *Nosema*, *Pleistophora*, *Vairimorpha*.

ASCOMYCOTA Berkeley,

1857 —

75%
 Fungi.

Pneumocystis carinii (Pneumocystidales) (. 187).

P. carinii Ascomycota.

1912

(),

рас-

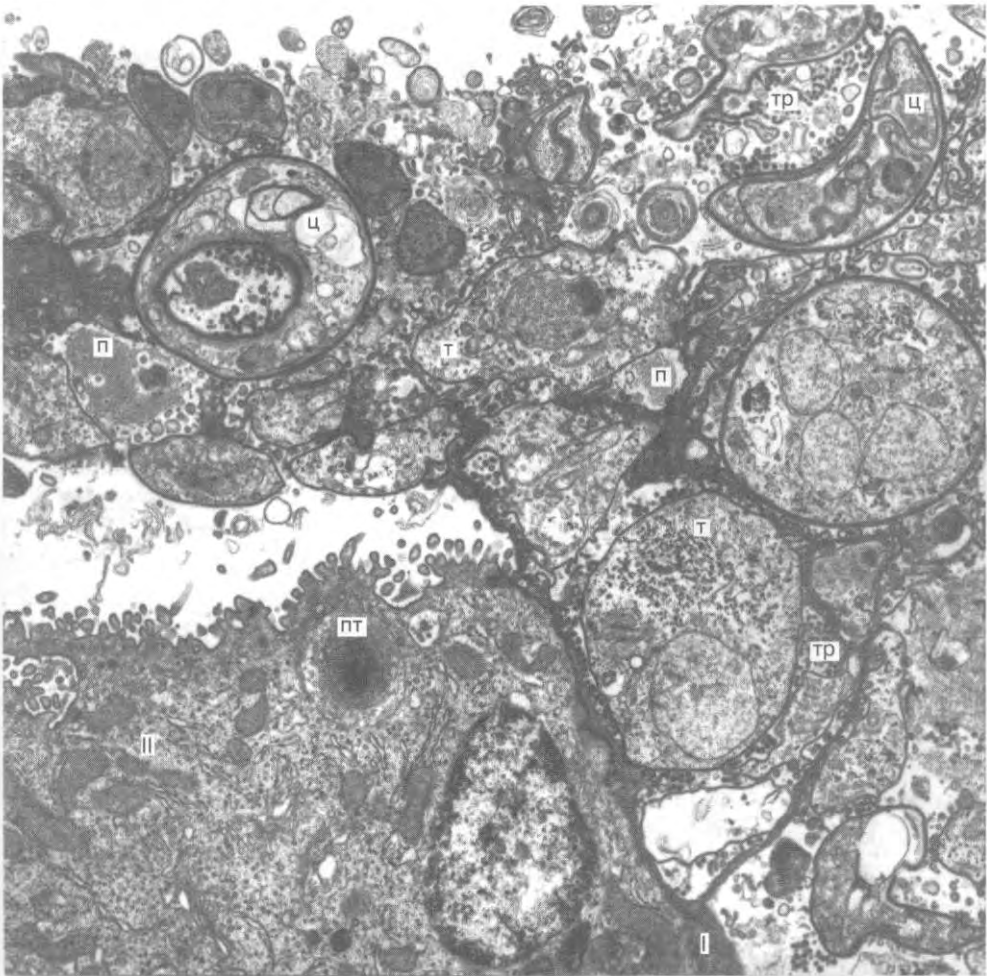

187. Eumycota, Ascomycota: *Pneumocystis carinii*. I (I), II, (), II, () *Pneumocystis* (: Kaneshiro et al.: J. Eukaryot. Microbiol. 40 [1993] 805). : 8 000x.

Pneumo-
cystis carinii,



Рис. 188. Ascomycota: схема внутрилегочного клеточного цикла *Pneumocystis carinii*. 1 —

1 — зигота; 2 — эндополигония; 3 — ранняя предциста; 4 — промежуточная предциста; 5 — промежуточная предциста; 6 — поздняя предциста; 7 — промежуточная предциста; 8 — поздняя предциста.

()

50%

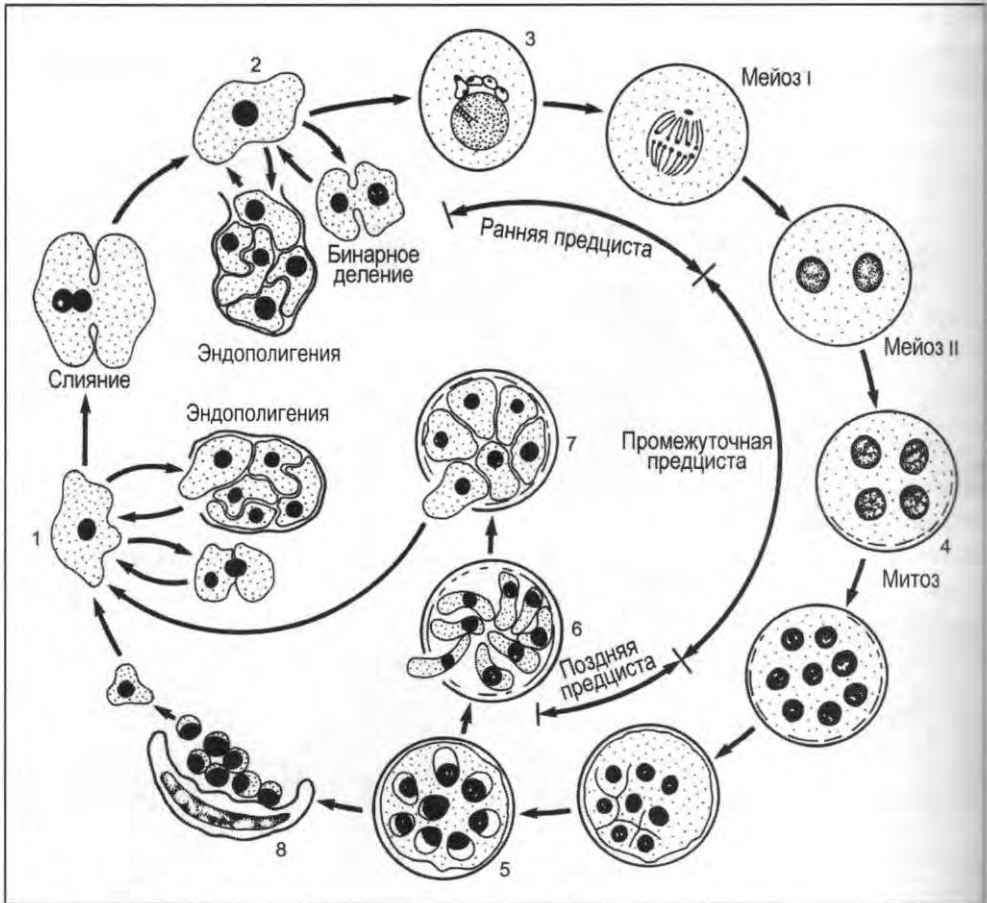
C. albicans

Hemiascomycota

P. carinii

Saccharomyces

cerevisiae,

(. 189,190).

Archaeascomyco-

ta — Schizosaccharomycetales —

(, *Schizosaccharomycespombe*).

Candida albicans

37 ° .

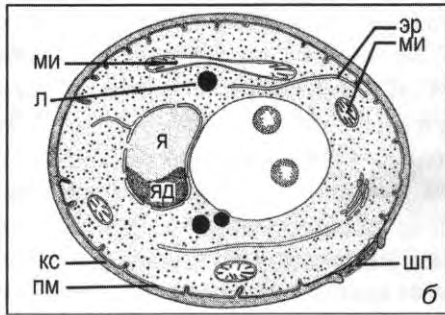
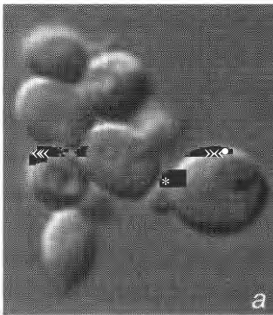

. 189. Ascomycota: *Saccharomyces*.

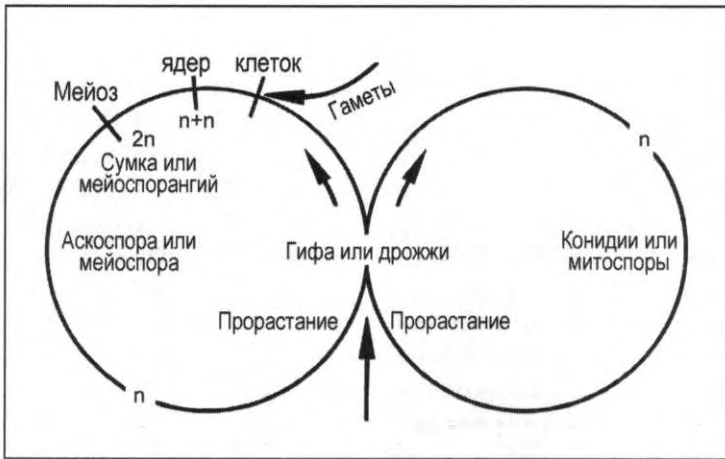

190. Ascomycota ()
)
 ()
 () ()
 ()

Nephridiophagidae

Sprague, 1970

Nephridiophagidae () 191 — это

— *Cryptococcus*.

Nephridiophaga apis

— *neoformans*.

Nephridiophagidae () « » —
 « » —)

Coelosporidiidae,

7 8% *Coelospo-
ridium*

(3 6%)

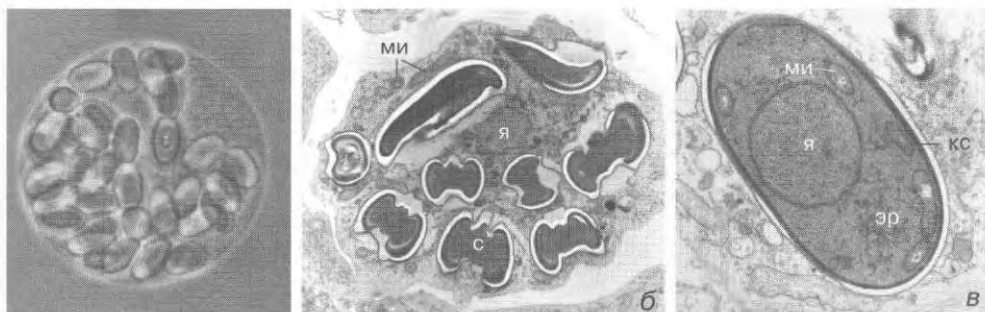

191. Ascomycota, Nephridiophagidae: *Nephridiophaga blattellae*:
 (); ()
 (); ()
 (), ()
 (). : - 1 800 , 6-4 , - 5

Nephridiophagidae

192). (5 10 2 4 ;
 : *Nephridiophaga*, *Orycto*
spora, *Coleospora*.

BASIDIOMYCOTA de

1866 —

Nephridiophaga blattellae,

« »

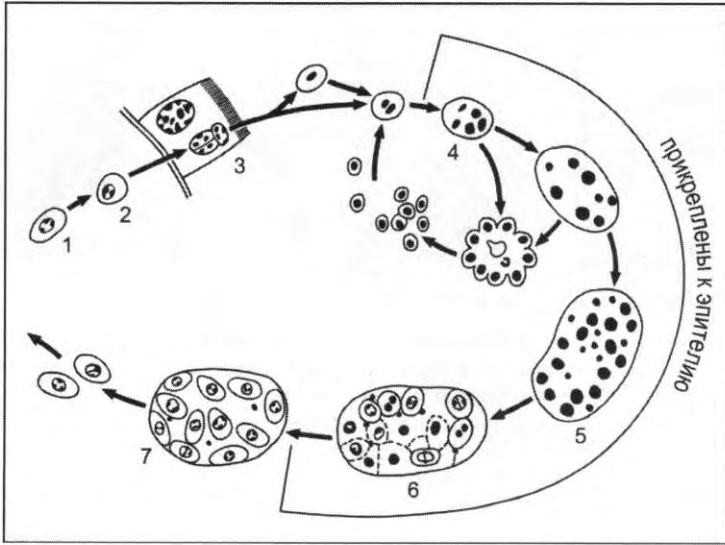

192. Nephridiophagidae:

Nephridiophaga blattellae.

- (1)
- (2)
- (3)
- (4)
- (5) —
- (6)
- (7) ()

CHOANOZOA Cavalier

Smith, 1981

DEUTEROMYCETES

(Metazoa),
Mesomycetozoa

()

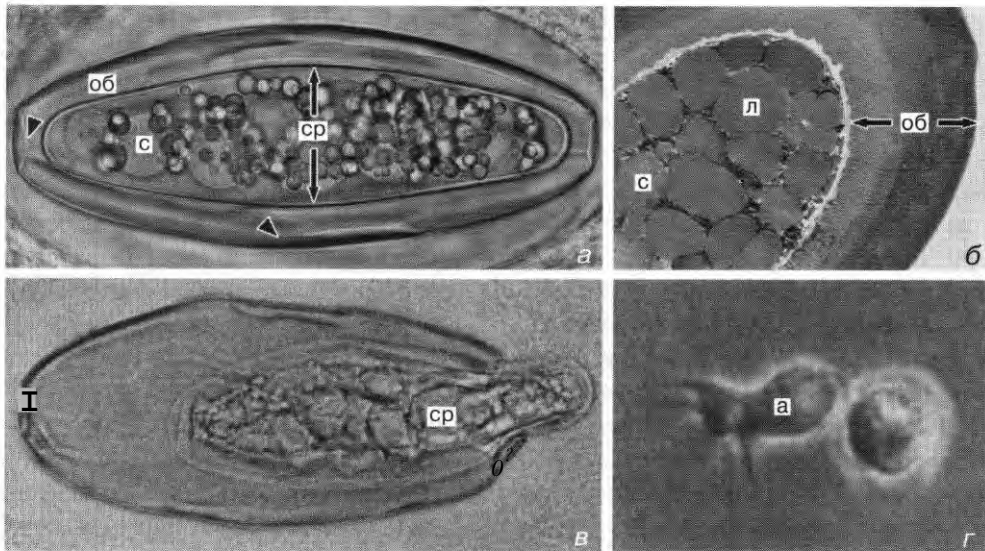

193. Opisthokonta, Choanozoa, Mesomycetozoa: *Psorospermum haeckeli* (, ,)
 (), —
 () (), () —
 ();
 (), — (), — ()
 (: Vogt and Rug: J. Exp. Zool. 283 [1999] 31). : a — 600x, — 1 600x, — 530 , — 1

DRIP —
 : *Der*
 : Choanozoa Mesomyce- *mocystidium*, rosette agent, *Ichthyophonus*
 tozoa Choanoflagellata, - *Psorospermium* (. 193).
 Metazoa. Ichthyosporea.

MESOMYCETOZOA Herr
 et al., 1999 *Rhinosporidium seeberi* DRIP
 . 1999
 Mesomycetozoa
 (« _____ »).
 . Mesomycetozoa
 Choanofla

gellata,	-	20	<i>Dermo-</i>
	Animalia ¹	<i>cystidium;</i>	
	Mesomycetozoa		
	;		
	-		
	-		
;	-		
	-		
	-		
	Psoro		
<i>spermium haeckeli</i>	<i>Ichthyophonus</i>		
<i>hoferi;</i>	<i>Dermocystidium</i>		
	-		
	in	agent, —	rosette
vitro,	-	;	
	-		
	6		
	-		
<i>Psorospermium, Ichthyophonus</i>	<i>Dermo-</i>		
<i>cystidium</i>	-		
:	-		
	-		
	-		
(-		
),	-		
	-		
	-	<i>Ichthyophonus hoferi</i>	
	(. 194).	()	80
	-		
	-		
	Mesomycetozoa		
	-		
	-		
	-		
	-	<i>I. hoferi</i>	

¹ Animalia Metazoa, Fungi

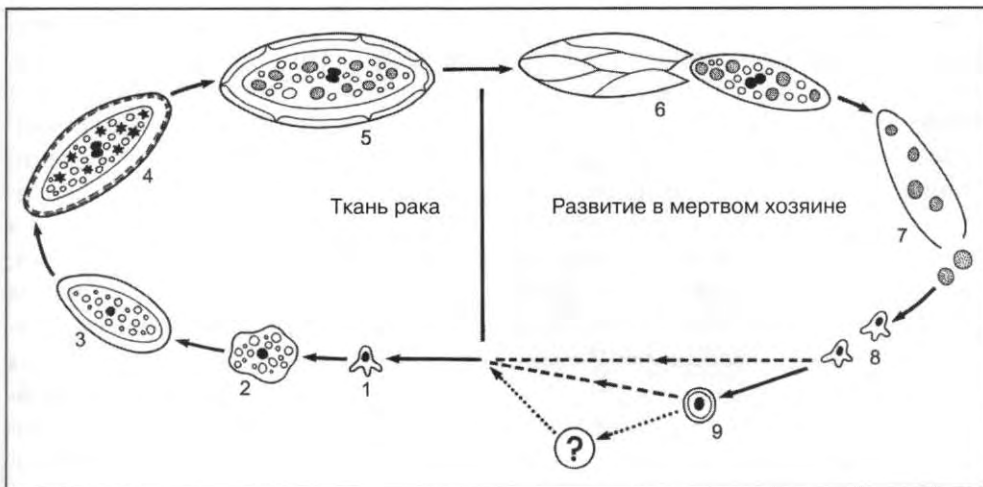

194. Choanozoa, Mesomycetozoa: *Psorospermium haeckeli*. 1 — , 2 — , 3 — , 4 — , 5 — , 6 — , 7 — , 8 — , 9 — , ? — (: Vogt and Rug: J. Exp. Zool. 283 [1999] 31).

(Eumycota)
Psorospermium haeckeli
 100 200
 Mesomycetozoa,
P. haeckeli
 Mesomycetozoa,

Amoebidium parasiticum, *Anurofeca richardsi*, *Sphaeroforma arctica*, *Rhinosporidium seeberi*.

273).

(. 195, . рнс. Choanoflagellata

().
Rhinosporidium seeberi

nosiga)

(*Codonocladium*);

: *Amoebidium*, *Anurofeca*, *Dermocystidium*, *Ichthyophonous*, *Rhinosporidium*, *Psorospermium*, *Sphaeroforma*.

(*Salpingoeca*).

CHOANOFLAGELLATA

Kent, 1880 —

1956).

10

Sphaeroeca volvox (300 500)

Proterospongia

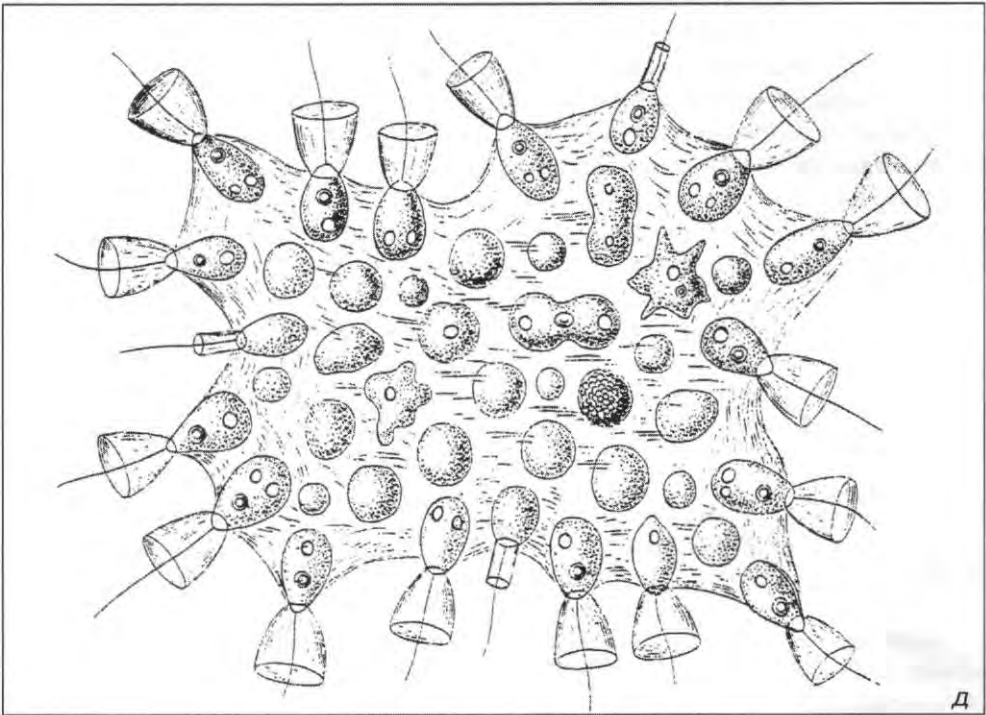
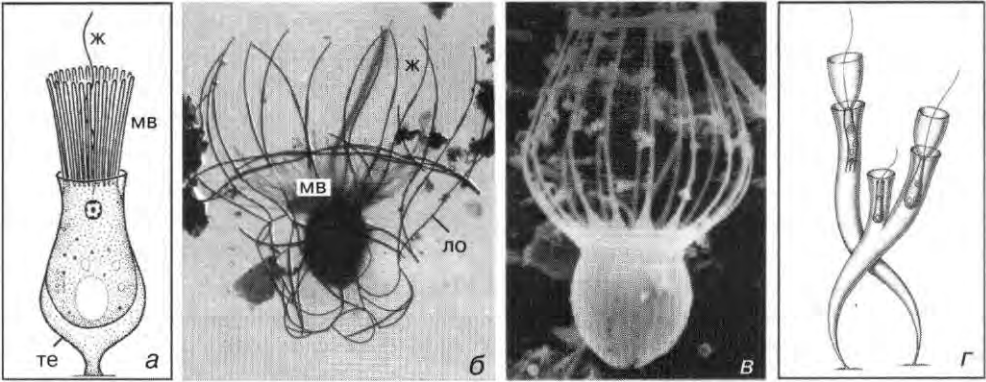

195. Choanozoa, Choanoflagellata: — *Salpingoeca amphoridium*
 (); — *Acanthoecopsis apoda* (), — *Diplothea costata*; — *Salpingoeca*
cornuta, — *Proterospongia haeckeli* 40 (—
 ; —).
 — 1 700 , 6 — 21 , — 2 900 , — 380 , — 1 200 .

(. 195).

— , — Meta-
zoa — , —
: Myxozoa.

Myxozoa —

()

MYXOZOA Grassé, 1970 —

1

1350

52

: *Codonosiga*, *Parvicorbicula*, *Salpingoeca*.

METAZOA Haeckel,

1874

Metazoa —

Cnidospora

Myxozoa (

196)

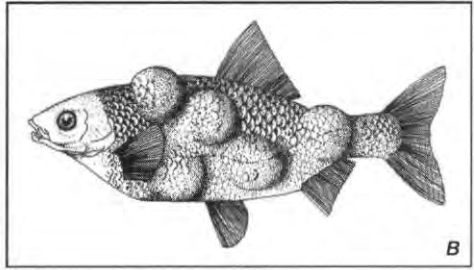
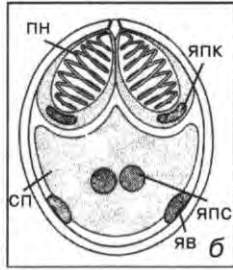
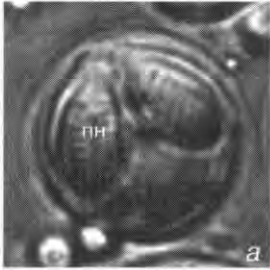

196. Choanozoa, Metazoa, Myxozoa: () ()
Myxobolus; — , — , — *Myxobolus*. — , —
 (— : Schmahl et al.: *Europ. J. Protistol.* 25 [1989] 26; —).
 ∴ — 2 200 .

— — — — —
 — — — — — (— . 197).
 — — — — —

18S
 Myxozoa —
 Narcome —
 Myxozoa —
 dusa Cnidaria. — Meta-
 zoa , Cnidaria — 1980 ,
 — — — — —
 — — — — — *Myxobolus*
 — — — — — *Tubifex tubifex*

197. Myxozoa: —
Leptotheca elon-
gata. —
 ()
 (), —
 —
 —
 ()
 ∴
 3 200 .

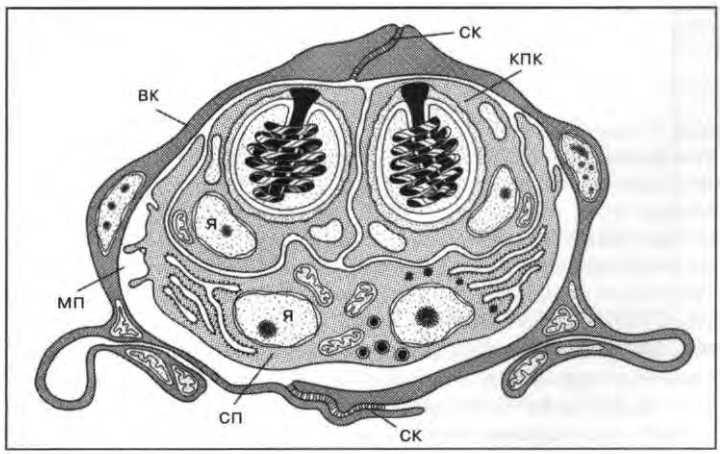

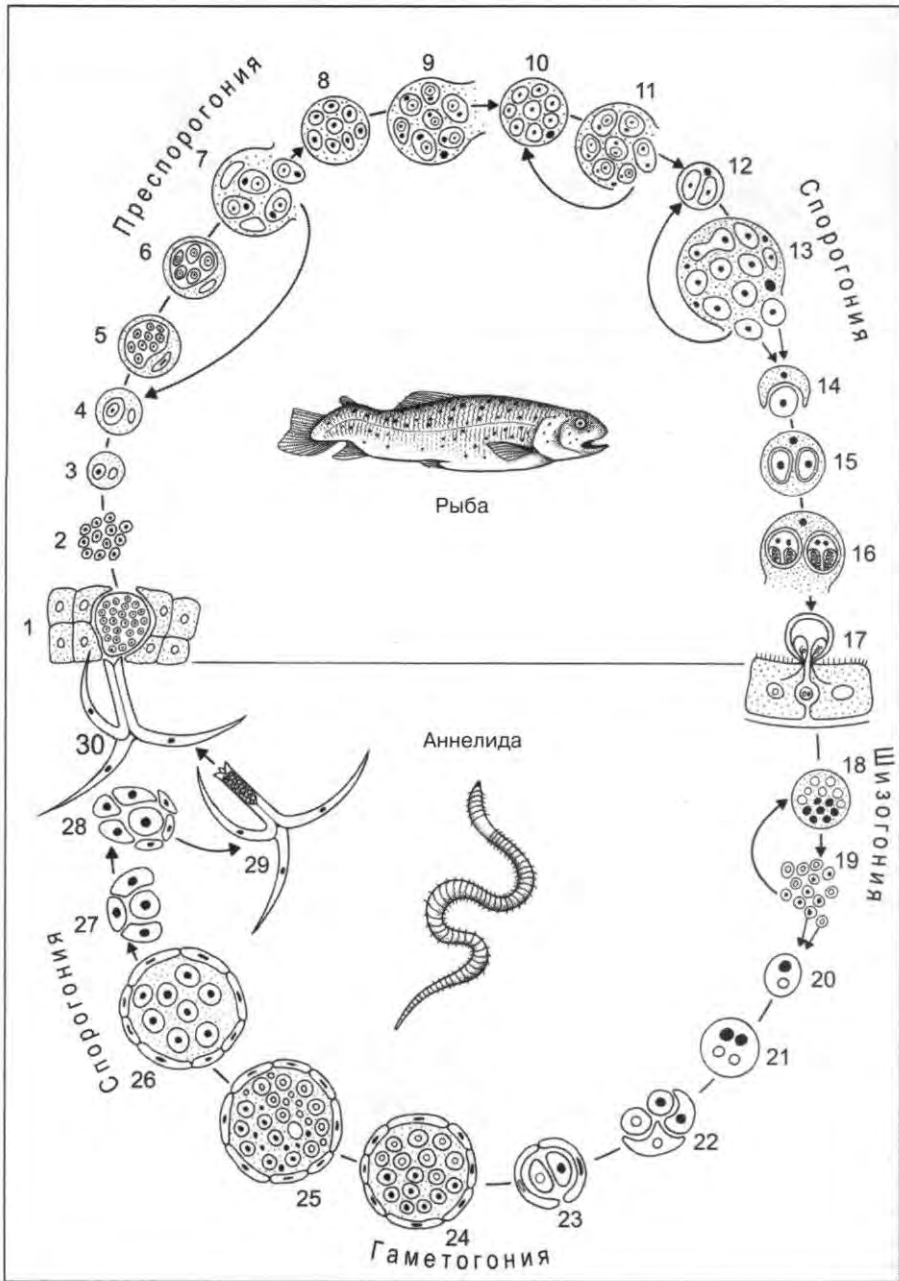

198. Мухозоа:

Myxobolus cerebralis. 1 16 —

Мухозоа,

; 17

30 —

. 1 —

; 2 —

(. 198).

— Myxosporea (

sporea (

6 — 12

Myxozoa.

Actinosporea

Myxozoa,

Myxobolus cerebralis (. 198).

; 3 13 —

21 26 —

; 24 25 —

8 . 27 29 —

(29)

(30);

Eukaryot. Microbiol. 48 [2001] 339).

198, 1 2; 199).

(. 198, 3 13).

(: Kent et al.: J.

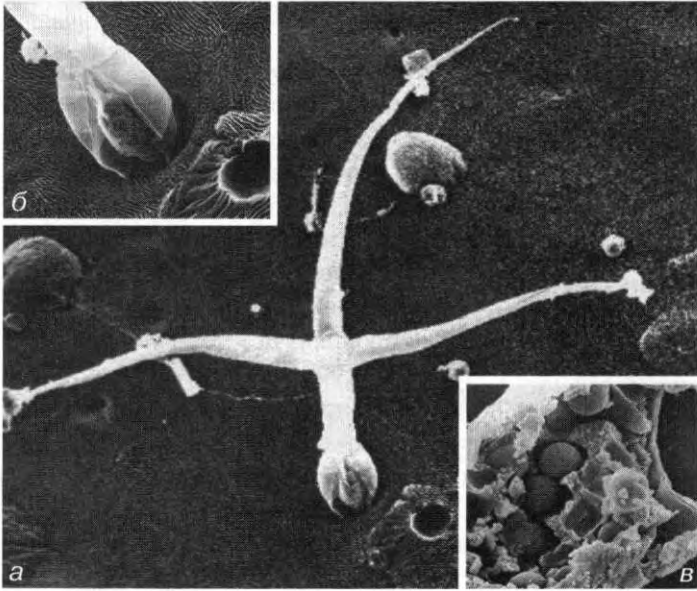

. 199. Myxozoa:

Myxobolus

cerebralis

1 - 700 , -
 , - 3 200 .

« »
 « ».

(. 198, 13 16).

. *cerebralis*,

),
 ()

16 16

8 (-)

198, 27 29) 8 (.

Myxo-

200). 8 (4,

Tetraspora)

bolus

(. 198, 17 20).

20 25)

(. 198,

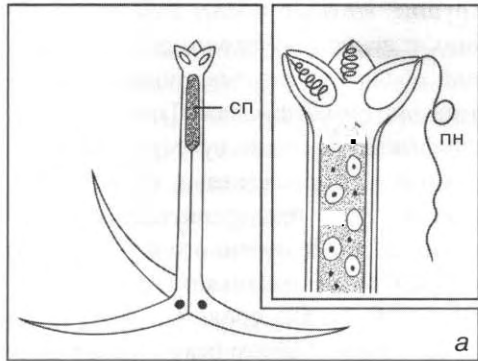

200. Myxozoa: —

Myxobolus cerebralis,

()

16 ; — ()

() ()

Myxozoa
pfeifferi,
 196);
 7
Myxobolus cerebralis

: *Henneguya*, *Myxobolus*,
Sphaerosoma.

EUKARYOTA incertae sedis

(
)

Sarcodina (

1. — .).

Sarcodina (DEC.

22)

(*)

ACTINOPODA* Calkins, 1902 —

(. 201).

(. 202).

(,)

(,)

),

. 201. Actinopoda,

Heliozoa:

: — Actinoph
rys sol

(), — ;

(—
).

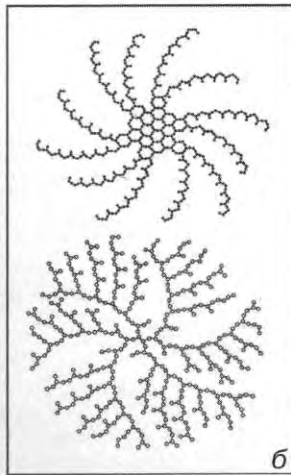
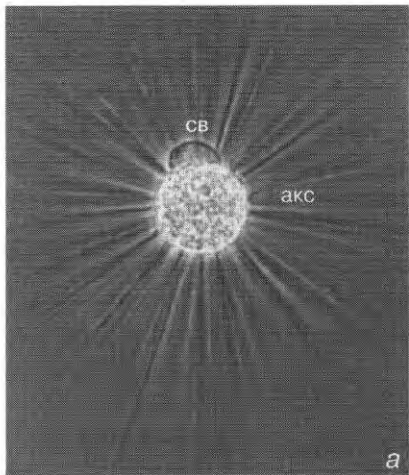

(. 203).
Actinopoda
Heliozoa Radiolaria.

Acantharea Haeckel, 1881 —

Radiolaria

(50 — 1)
10 20

(. 205, 206);

(),
() (. 204).

1

2

2003 ..

(— — — — —).

Cercozoa

Cercozoa.

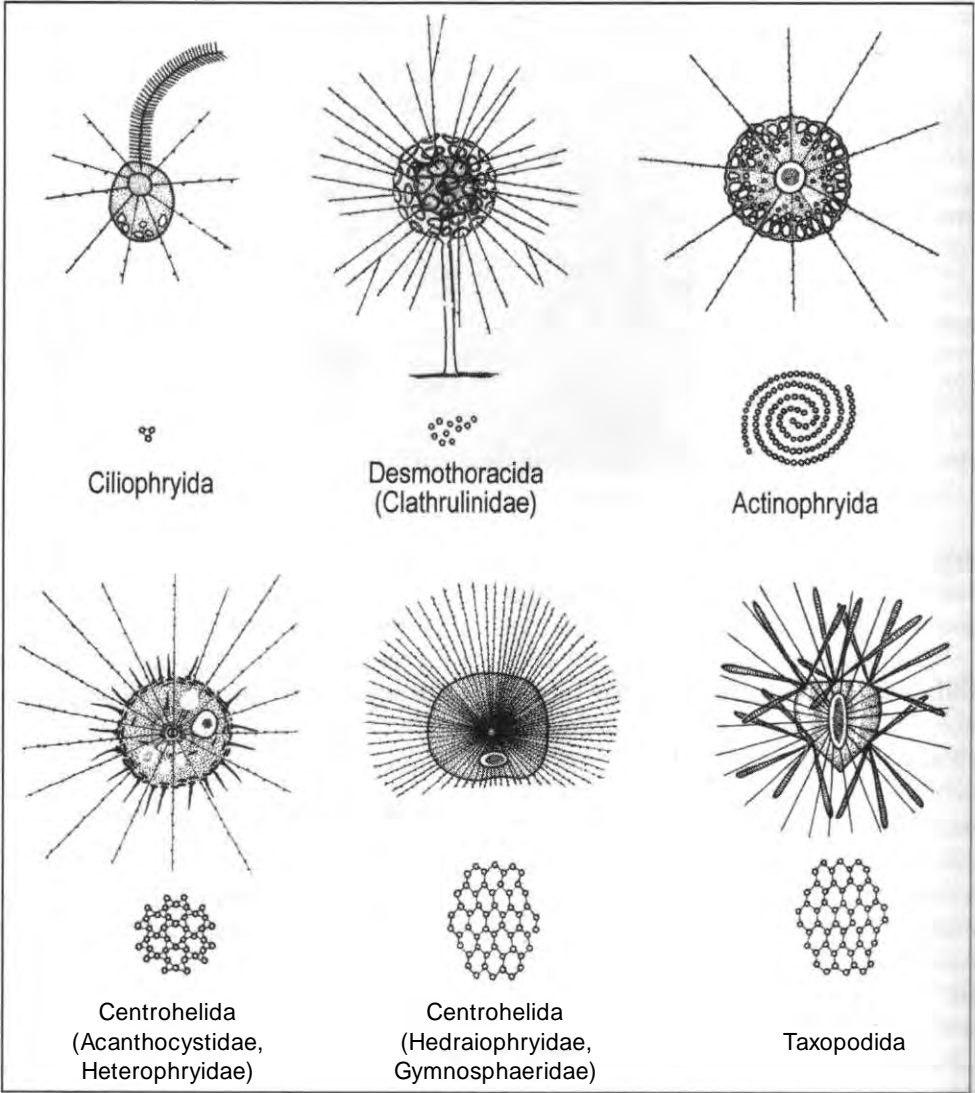

. 202.

).

()

;

;

;

;

;

;

;

;

;

;

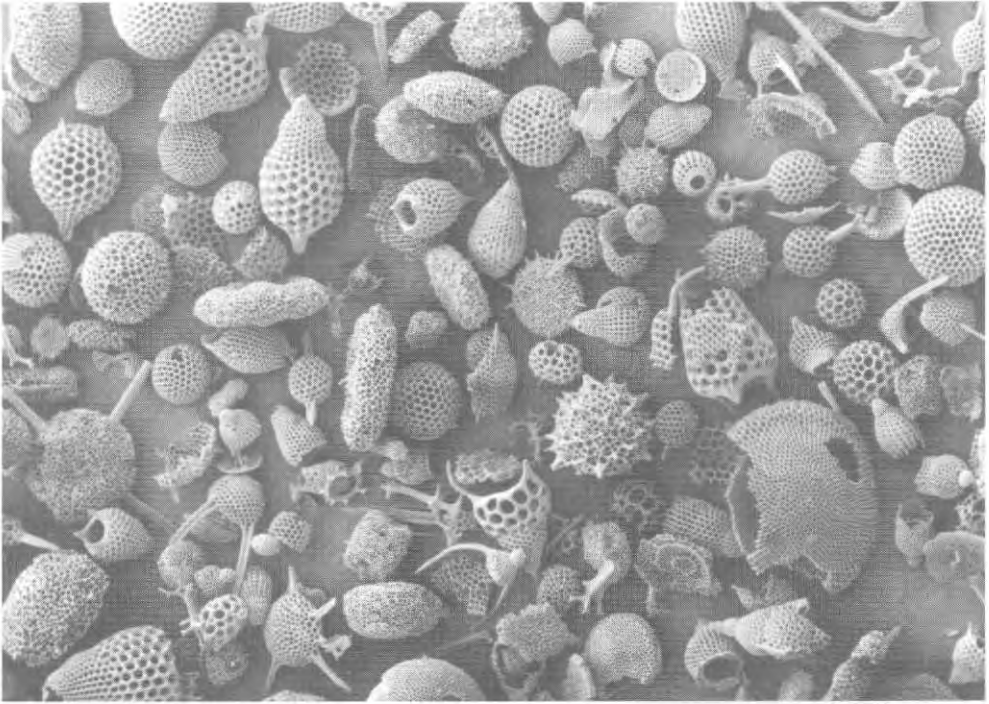

203. Polycystinea:

: 200 .

204. Acantharea:

— ;
 — ; —
 — (—)
 ; —)
 : — 40 .

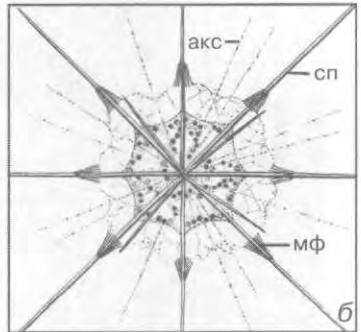
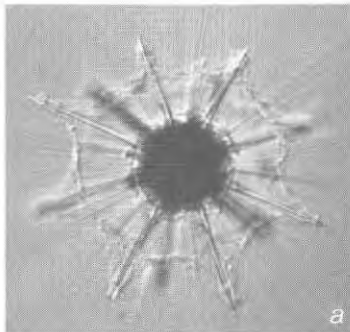

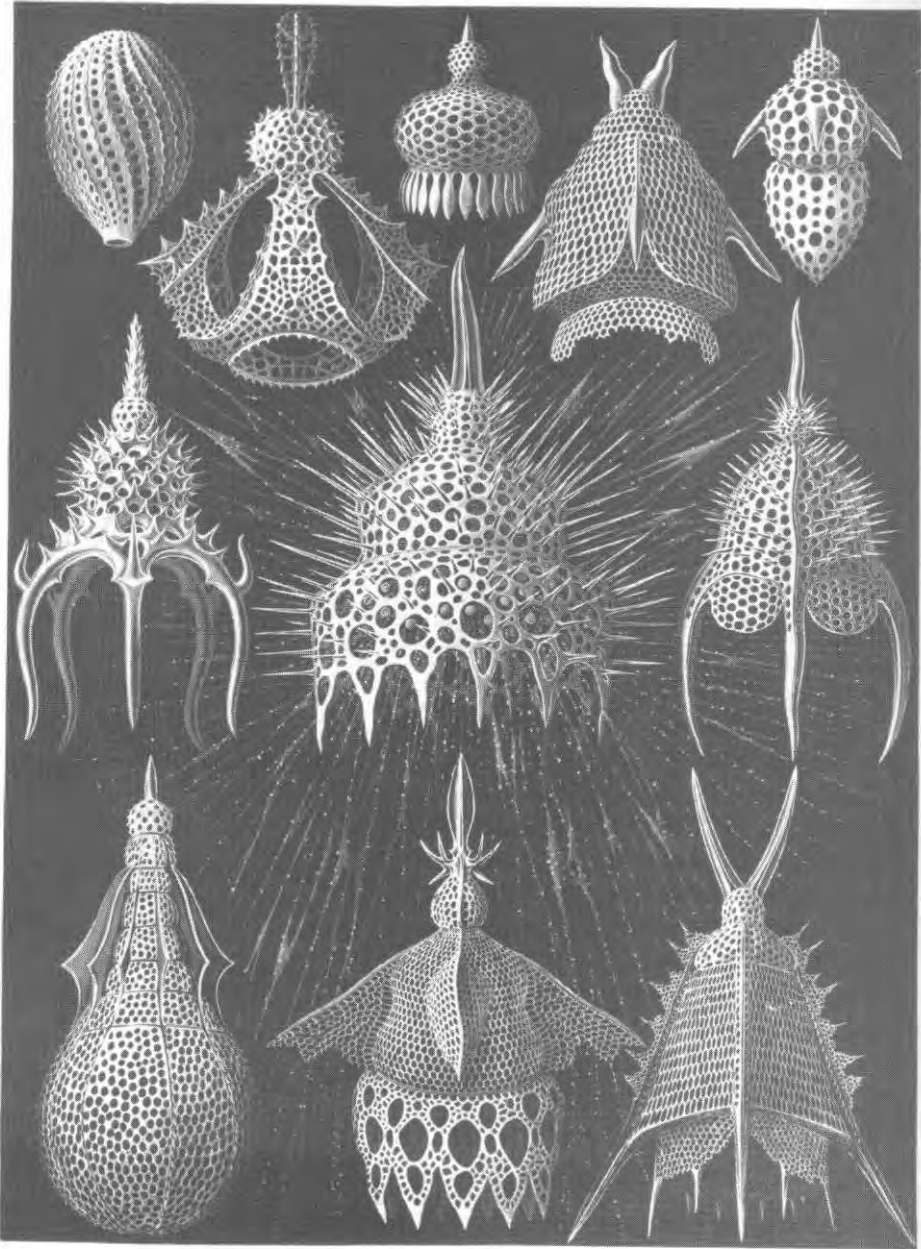

Cyrtoclema.

„ , • * • ' • ; . »

. 205. Polycystinea: Nasserida (: Haeckel: Kunstformen der Natur. Verlag Bibliogr. Inst., Leipzig and Wien, 1899 1904).

4 : Holocanthida (10),
 Symphyacanthida, Chaunacanthida Arth
 racanthida (20), —

: *Acanthocolla*, *Acantholi*
thium, *Acanthometra*, *Amphiacon*.

Polycystinea Ehrenberg, 1838 —

30 6
 2 , 12 ;

(. 205).

Polycystinea;

(. 206).

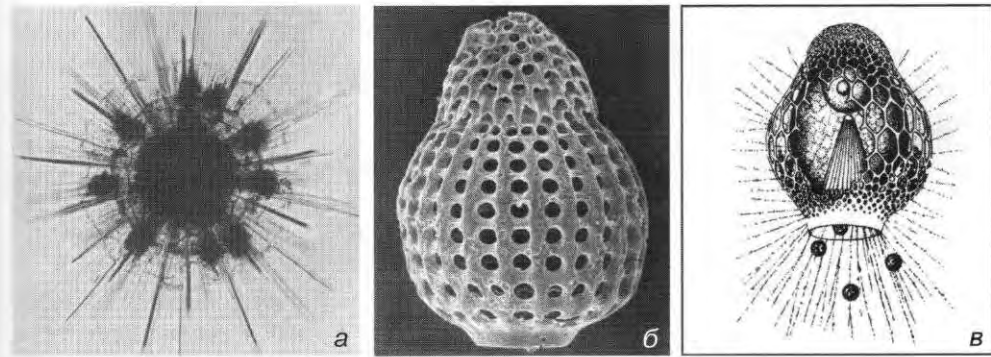

. 206. Polycystinea: — ; — ; —
Cyrtocalpis urceolus (— ; — ; — : K.Q. Qrell:
 Protistology, Springer, Heidelberg 1973). : a — 200x, — 400x, — 260x.

SFUMBBIARIA VASSKXLASXA TAF. IS.

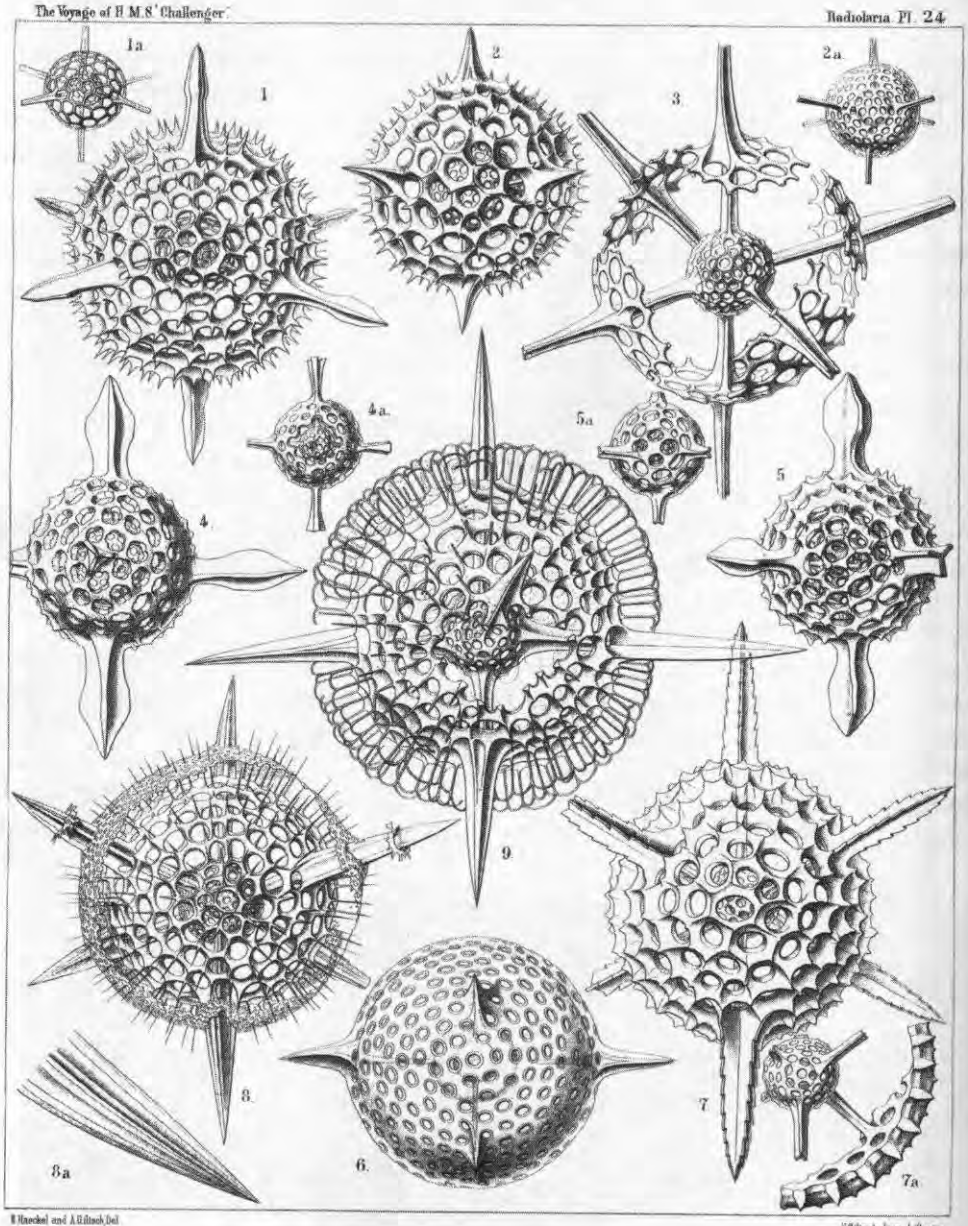

1.7 HEXACANTIUM. 8.0 HEXACROMYIUM

. 207. Polycystinea: (: Haeckel: Die Radiolarien (Rhizopoda, Radiolaria) 2. Theil. Berlin, 1887).

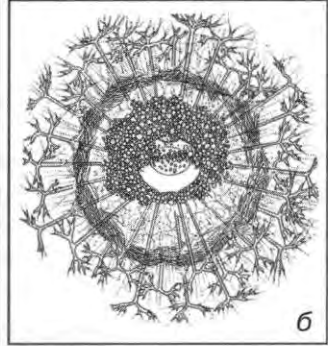
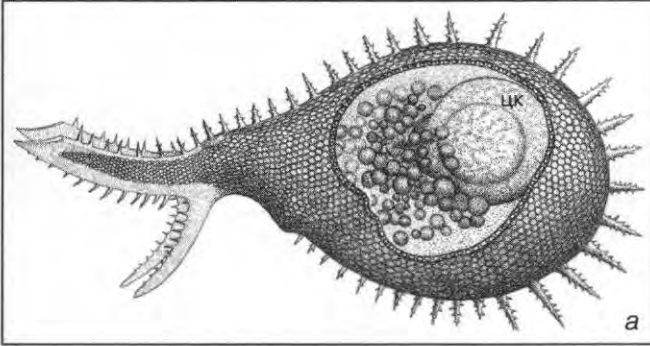

208. Phaeodarea: — Challegeyron wyvillei: () ; — Auloceros elegans (— , —). : — 260 , — 20 .

mellaria

Spu

Nasselaria

(. 2066,).

Spumellaria Nasselaria - 205 207.

(. 208).

: Collozoum, Eucoronis, Thallasicolla.

(Phaeocalpida,

Phaeodarea Haeckel, 1881 —

Phaeoconchida, Phaeocystida, Phaeodendrida, Phaeogromida, Phaeogymnocellida Phaeosphaerida)

darea

Phaeo-

: Astracantha, Aulacantha, Coelodendrum, Phaeodina.

HELIOZOEAE* Haeckel, 1866

(. . . 202),

(. . .).

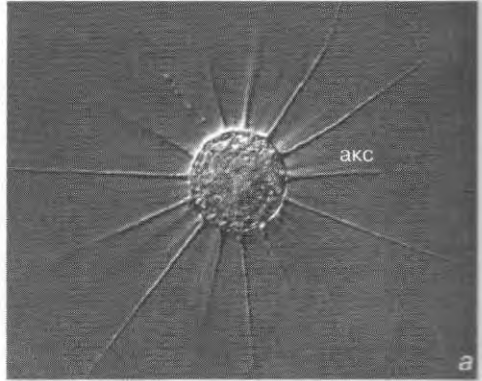

Actinophryida Kuhn, 1926 —

(. . . 202).

(. . . 209).

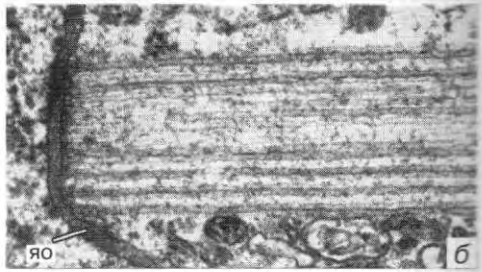

. 209. Heliozoa: — *Actinophrys sol* (. . .); — (. . .); — (. . .); — (. . .), 6 — 58

(. . . 202).

: *Actinophrys*, *Actinosphaerium*, *Camptonema*.

Desmothoracida Hertwig & Lesser, 1874 —

(. 210).
 : *Clathrulina, Hedriocystis, Orbulinella.*

Ciliophryida Febvre Chevalier, 1985 —

(. 202).
 : *Actinomonas, Ciliophrys, Pteridomonas.*

Taxopodida Fol, 1883 —

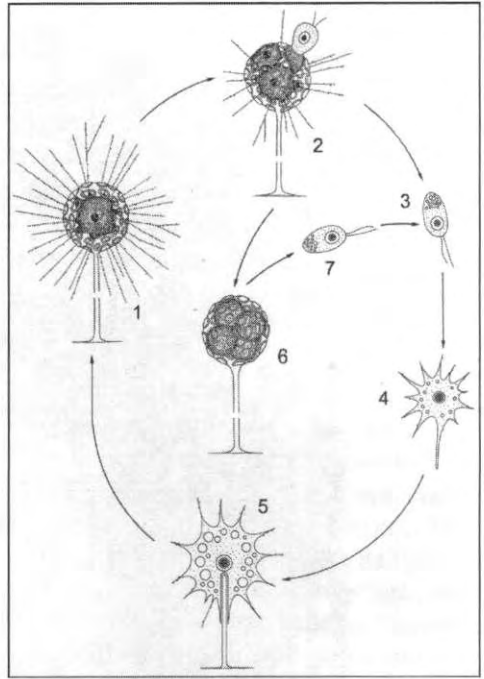

. 210. Heliozoa, Desmothoracida:

Clathrulina elegans.
 (1)
 (2)
 (3),
 (4).
 (5)
 (1).
 (6).
 (7),
 (4),
 ()).

Centrohelida Hartmann, 1913 —

(. 211).

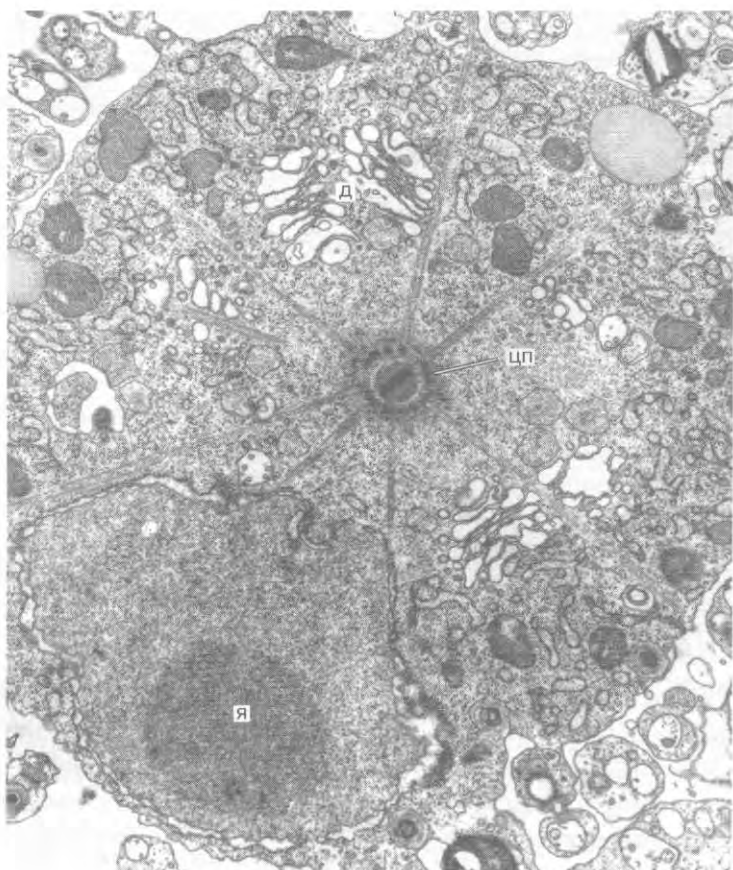

211. Centrohelida: *Heterophrys marina*; (). — (: Bardele: Cell Tiss. Res. 161 [1975] 85). 40 000x.

(. . 202).

: *Acanthocystis*, *Gymnosphaera*, *Hedraiphrys*, *Heterophrys*.

PARAMYXEA Levine, 1979 —

(. 212).

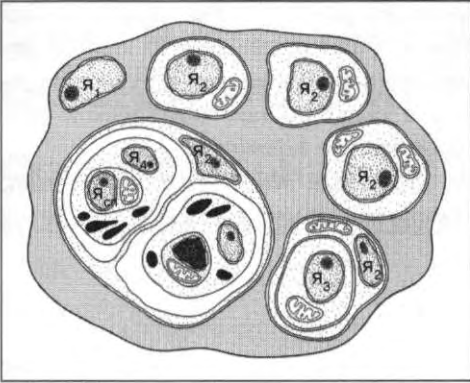

212. Paramyxea:

Paramarteilia orchestiae.

Paramarteilia.

Haplospora.

(9x1+0).

30

teilia

(*Ostrea edulis*).

Para-myxea

Chytri

diomycota, Microsporea,

Labyrinthomyxa, Myxozoa

(Haplospora) -
 Ascetospora. -
 -
Marteilia refringens ,
 ,
 Haplospora. Paramy *Paramyxa*. : *Marteilia*, *Paramarteilia*.

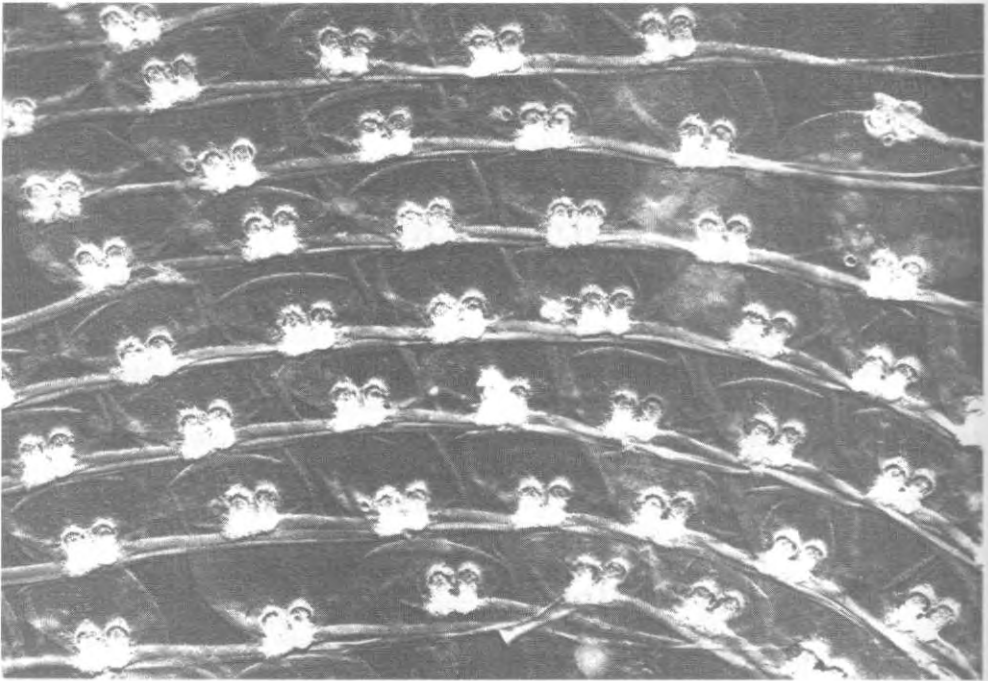

213. *Paramecium*
 : 12 000 .

()

(. . 168),

¹ (. . 9, 176).

² (. 218)

(,)

(,), () ,

(. 217).

1

2

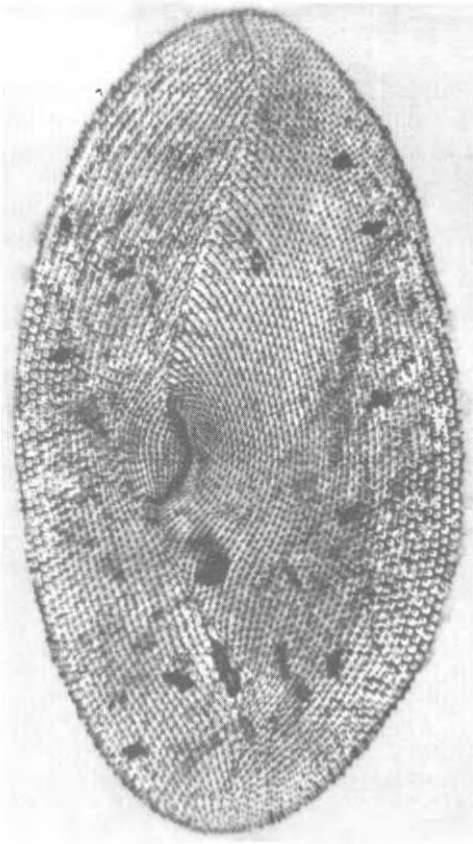

. 214.
Paramecium (

Pleurochrysis

(. 219).

Eufolliculina uhligi (. 220).

(. 221).

, *Actinophrys*.

15

1

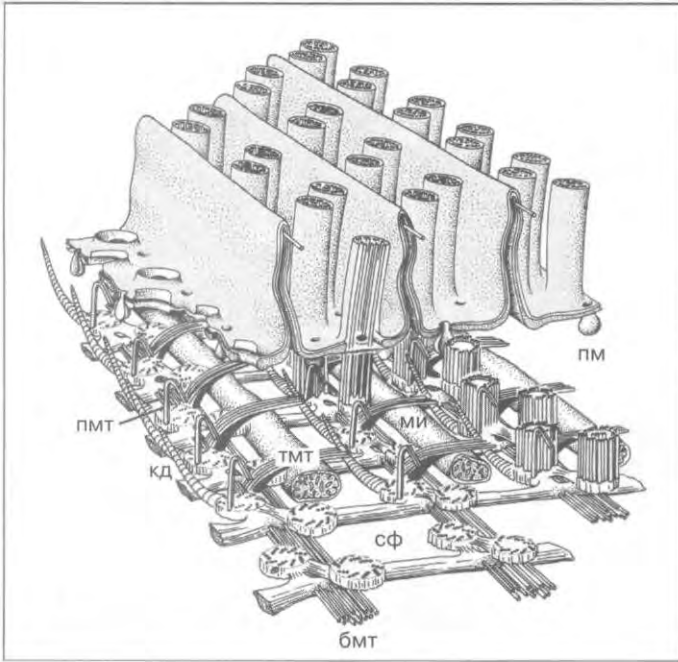

215. *Conchophthirus curtus*.
 — ПМ
 — ПМТ
 — КД
 — ТМТ
 — МИ
 — сф
 — БМТ
 ()

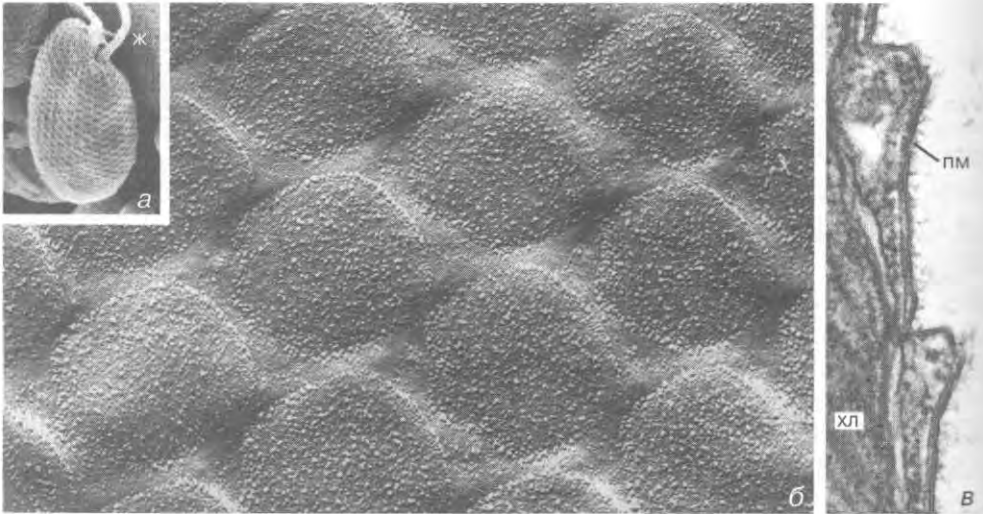

216. *Rhodomonas*.
 ()
 — ПМ
 — ХЛ
 (: Hausmann and Walz: Protoplasms 101 [1979] 349).
 : a 2 800x, б 4 8 000x, в 80 000x.

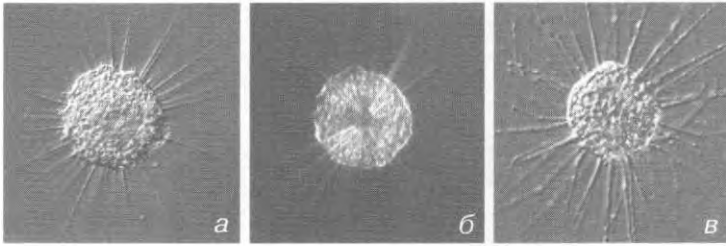

217. *Actinophrys sol* (); (); ().

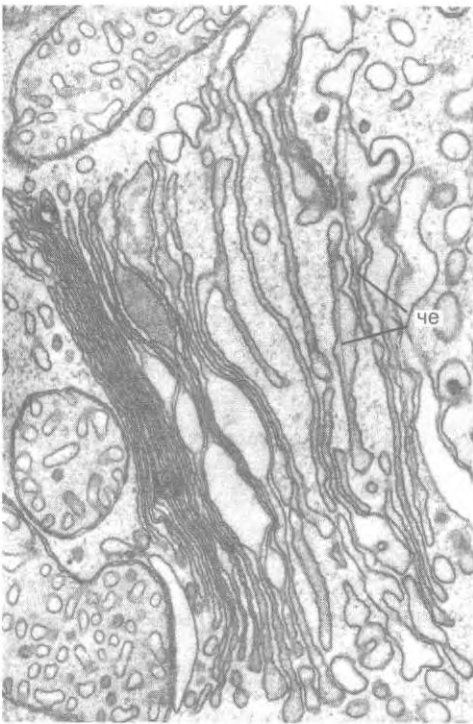

218. *Pleurochrysis* () ().

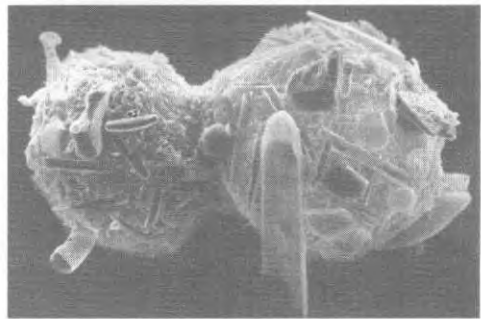

219. *Diffflugia*; ()

270

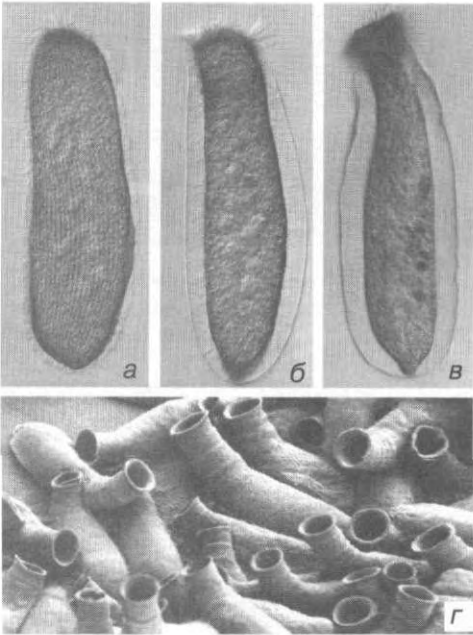

220. *Eufolliculina*
 ()
 (,).
 () (: Mulisch and Hausmann: J. Protozool. 30 [1983] 97).
 — 140x, — 80x.

),

Paramecium.

Paramecium.

Amoeba proteus.

Stentor

(*Vorticella, Carchesium, Tokoph*) (. 141, 142, 144),

(. 222)

(*Tricho*

. 221. *Acanthamoeba* (a), *Climacostomum* (), *Actinosphaerium* (), *Frontonia* () (—

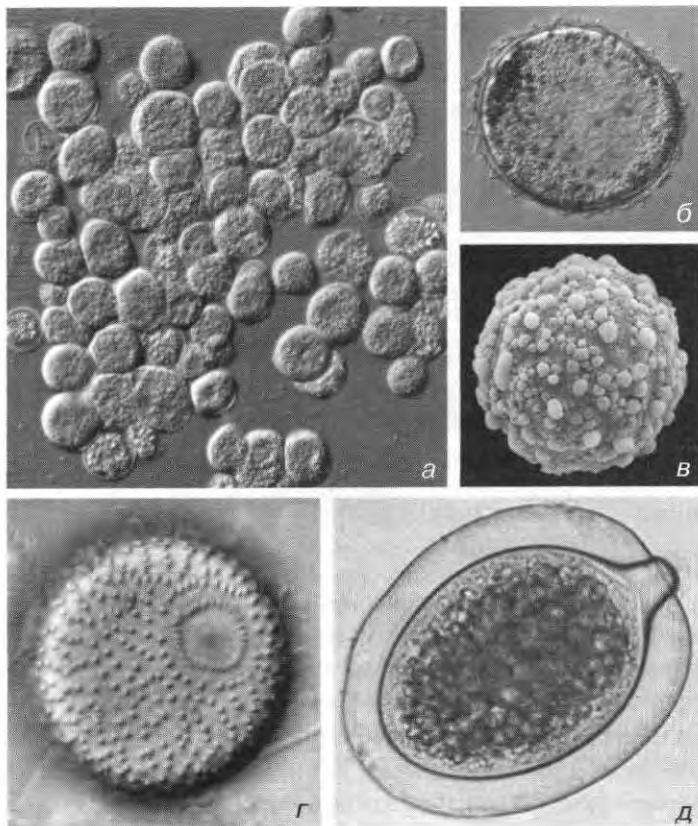

Hausmann and Rambow: Mikrokosmos 74 [1985] 208; — : Hausmann and Foissner: Mikrokosmos 75 [1986] 193).
 .: a 500x, 250x, 700x, 600x, 400x.

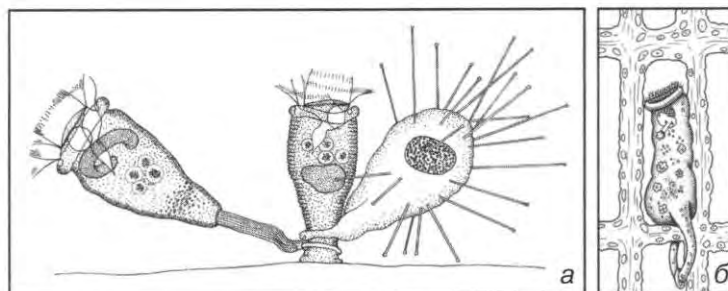

. 222. *Erastophrya chattoni* (), *Ellobiophrya donacis*, *Donax vittatus* (— ; —) . *Epistylis lwoffii* () *Apiosoma amoeba*; — .
 .: — 550 , — 450 .

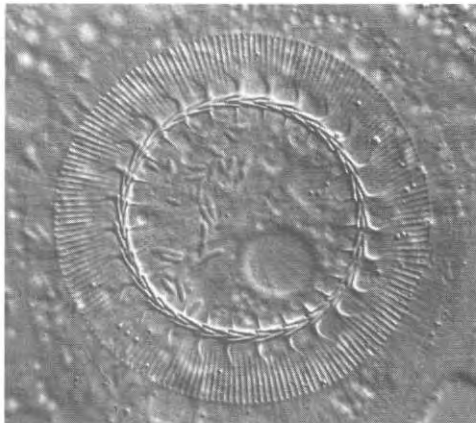

. 223. *Trichodina*
(: Hausmann and Hausmann: J. Ultrastruct.
Res. 74 [1981] 144). : 850x.

dind) (. 223).

(. . 39),

(. . 91)

()

Poteriochromonas,

224),

225.

¹ (. . 210).

. 224.

monas malhamensis (Chrysoomonadea) ()
 (: Schnepf et al.: Planta 125 [1975] 45).

Poterioochro

()

: 4,000 .

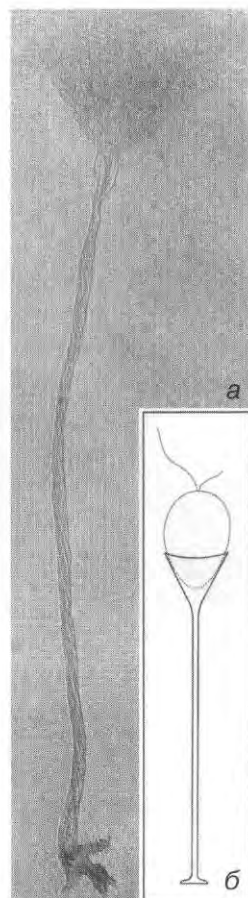
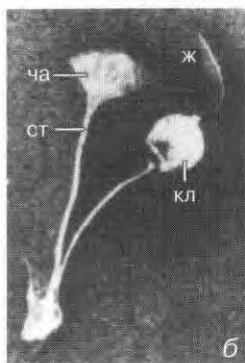
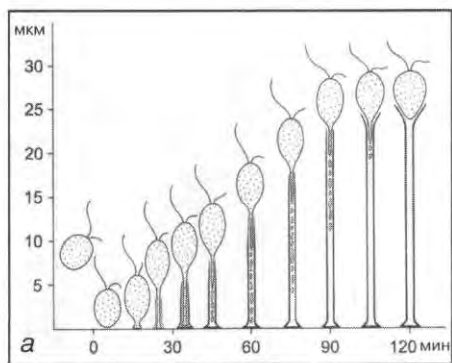

. 225. —

monas; —

Poterioochro

(— , — ; —)
). : — 1 .

Sorogena (. 226).

60

30

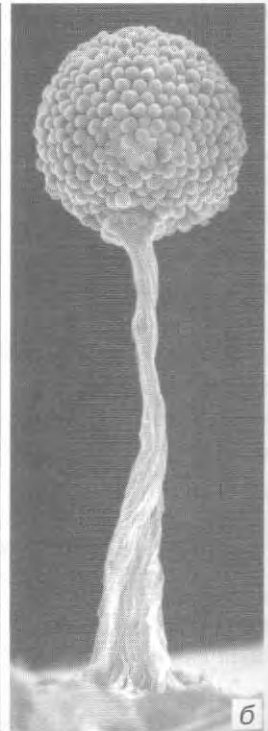
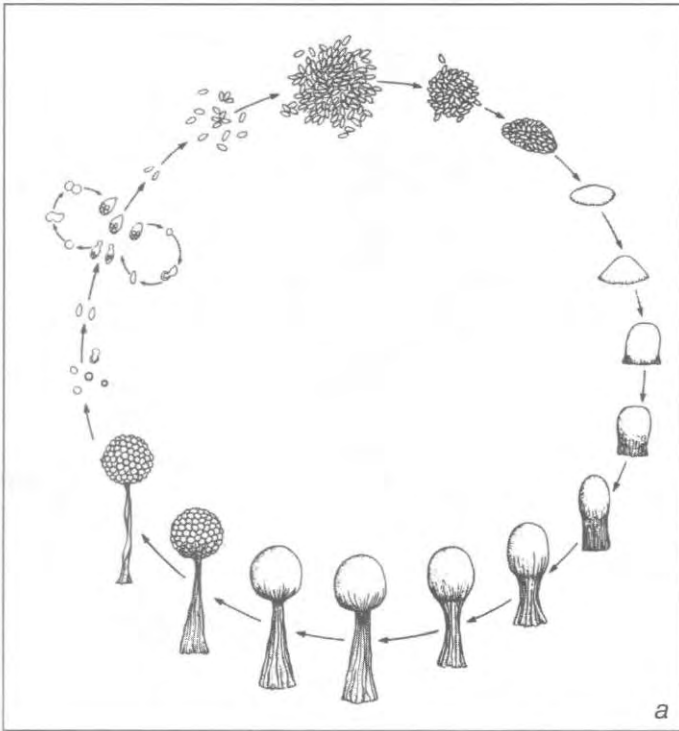

226. — *Sorogena*; — *Sorogena* (— ; — : Olive and Blanton: J. Protozool. 27 [1980] 293). — : — 120x.

chodind)

(. . 223).

(. 196, 197),

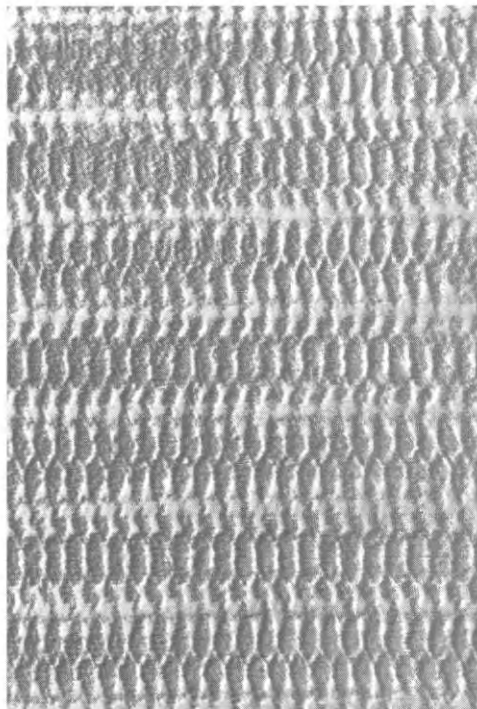

. 227.
Paramecium (: Hausmann: Ann. Stat.
 Biol. Besse en Chandesse 7 [1973] 331).
 .: 260 000x.

15

Paramecium (.

17, 227).

16

).

16.

			(?)	

(. 228).

Paramecium

7

8
;
(. 229).

56

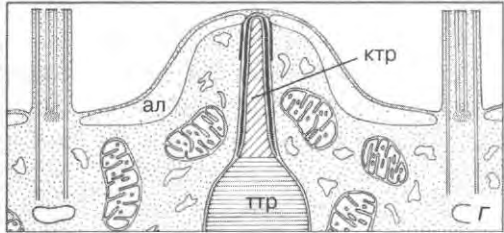
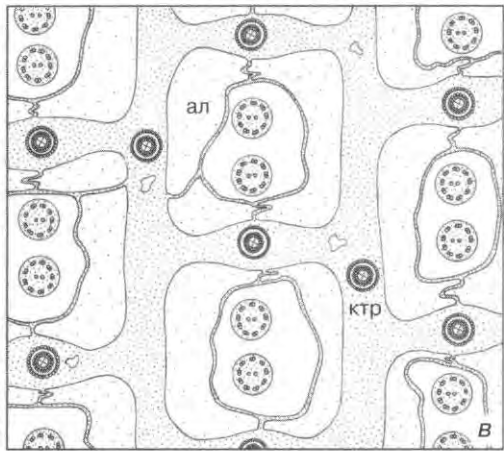
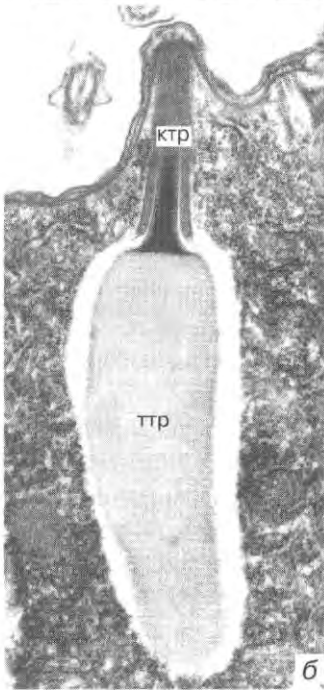
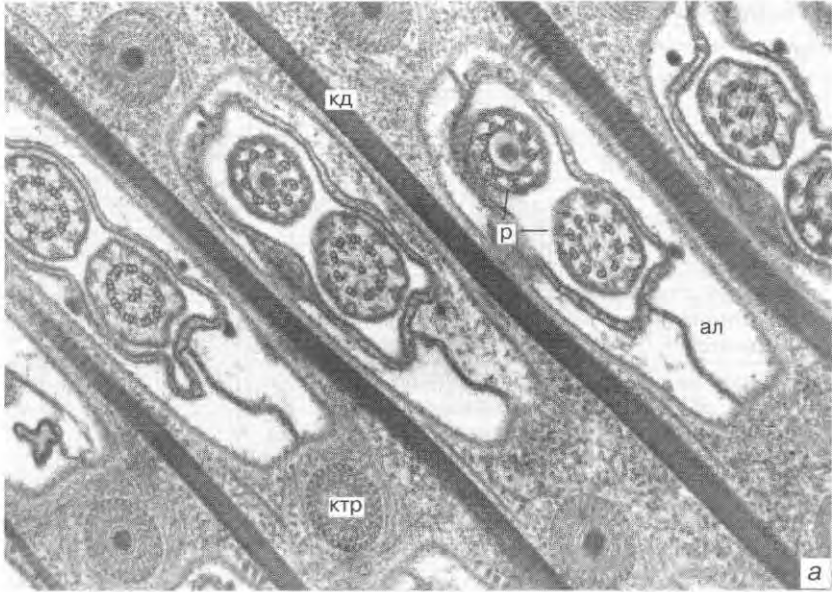

228. *Paramecium*: (), — () (: Hausmann: Int. Rev. Cytol. 52 [1978] 197). : a 52 000x, 6 — 24 000x.

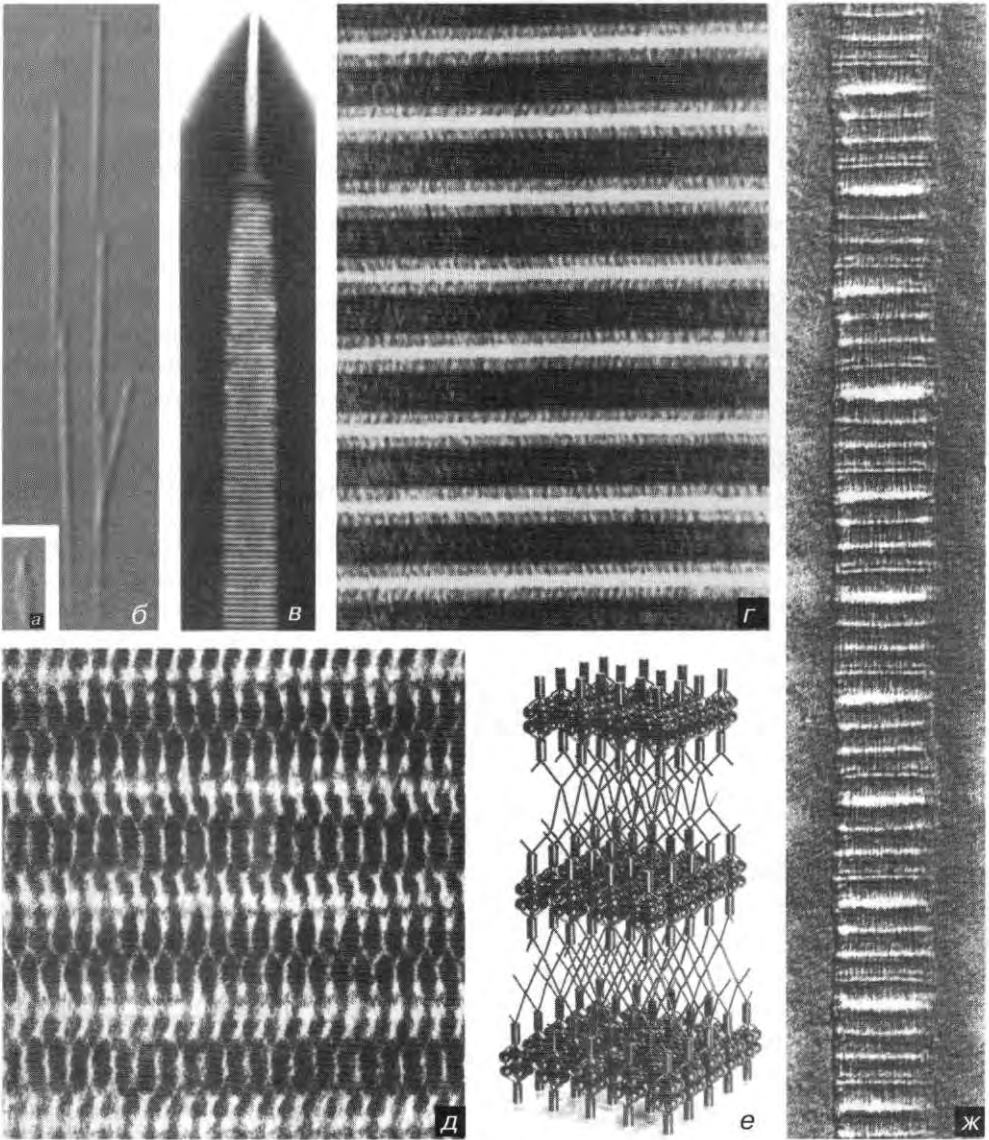

. 229. *Paramecium* () *Oxyrrhis* (): — —
 ; — (— —
 , —); — —
 ; — ; — —
 (: Hausmann: Int. Rev. Cytol. 52 [1978] 197). : а 900x, 900x, s
 11 000x, 220 000x, 330 000x, 200 000x.

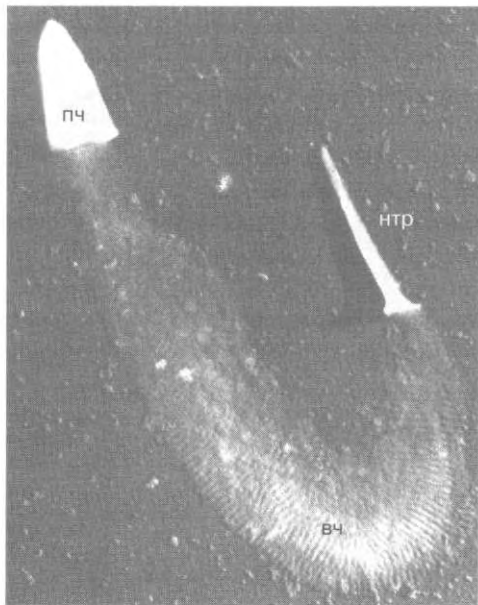

Paramecium

58

Para-

. 230.

)

Paramecium,

(: Hausmann: Int. Rev. Cytol. 52 [1978] 197). : 15 500x.

(. 231),

(. 230).

(, *Didinium*)

Paramecium.

« — »

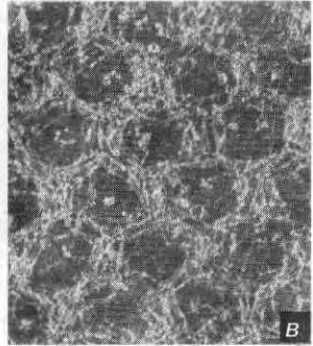
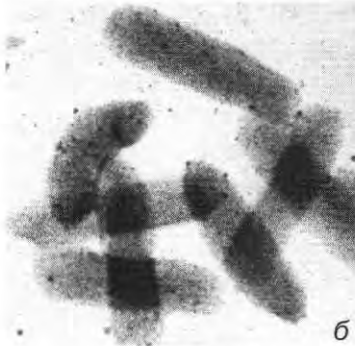

. 231.
Loxophyllum
 ()
 (,);

(), —
Clathrulina ()
Acanthocystis (), —

Raphidiophrys contractilis

— ()
 — : Hausmann: Int. Rev. Cytol. 52 [1978] 197;
 : Bardele: Z. Zellforsch. Mikrosk. Anat. 130 [1972] 219; e — : Sakaguchi et al.: Europ. J. Protistol. 37 [2002] 453). : a 57 000x, b 7 200x, c 132 000x, r 38 000x, s 73 000x.

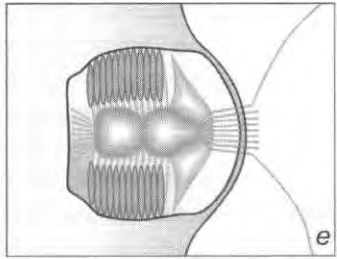
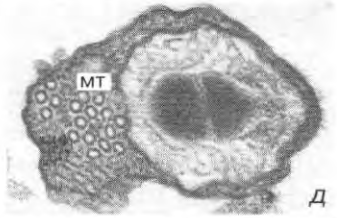
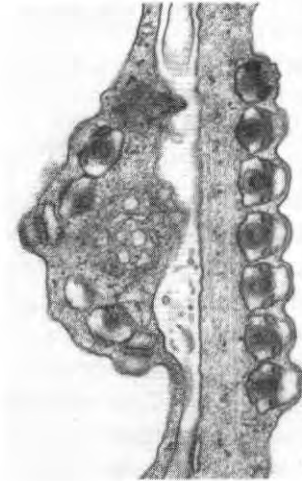

Euglenida

Oomycetes

87). (. 86,

(. 88, 98)

()

(, *Blepharisma*

Stentor)

(, *Loxodes* *Trachelonema*).

. *japonicum*

0,3

0,6

Dileptus,

Apicomplexa

Stentor coeruleus

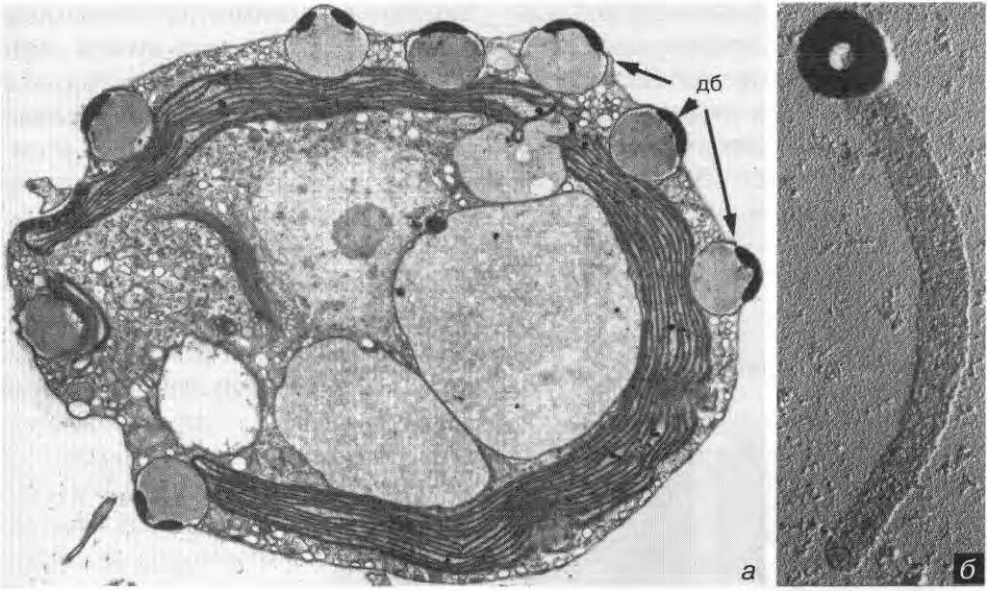

. 232. : — *Ochromonas tuberculatus*
 (); — (: Hibberd: Brit. J.
 Phycol. 5 [1970] 119). : a — 7 000x, б — 11 000x.

Stentor

Blepharisma

virens

Climacostomum

(. 232).

() ,

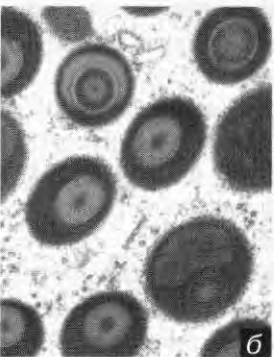
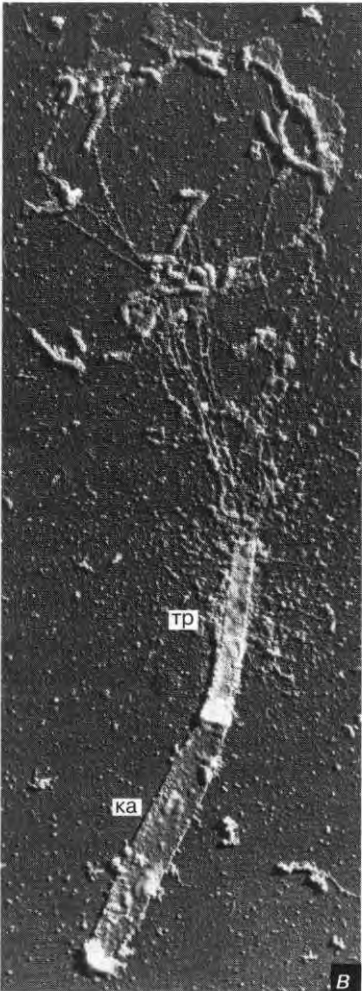
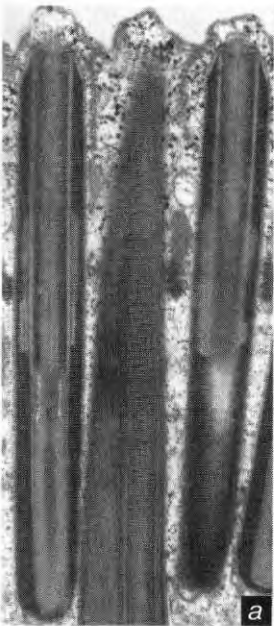

. 233. *Homalozoon* (,)
Loxophyllum () :
 () ; —
 — : Kuhlmann and Hausmann: *Protistologica* 16 [1980] 125; — : Hausmann and Wohlfarth Bottermann: *Z. Zellforsch. Mikrosk. Anat.* 140 [1973] 235). : a 35 000x, 6 3 5 000x, s 15 000x.

233).

(. 234).

Haptoria

Trachelonema sulcata *Tracheloraphis dogieli* *Trachelonema*

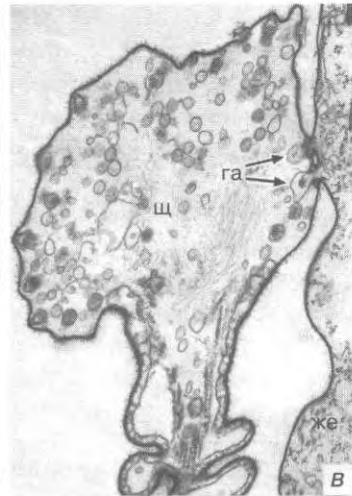
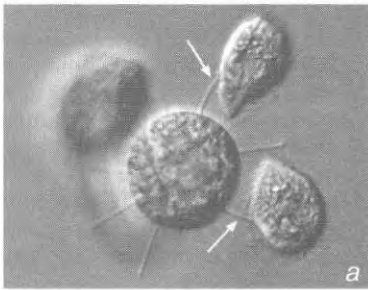

. 234. () ; — () ; — () ; — () () — : Bardele and Grell: Z. Zellforsch. Mikrosk. Anat. 80 [1967] 219). : a 250x, 6 2 2 000x, 22 000x.

(. 235).

R (refractory,

Paramecium.

R

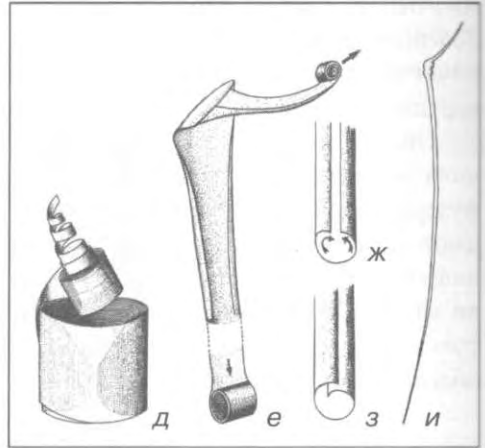
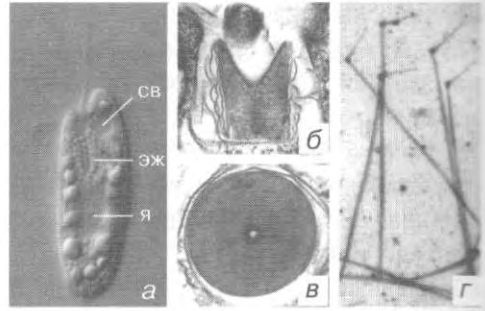

. 235.

Chilomonas Paramecium:

() () () ;
 ;
 ()
 () (: Hausmann: Int.
 Rev. Cytol. 52 [1978] 197). : a 2 600x,
 6 1 9 000x, — 30 000x, — 5 000x.

(. 236).

. 236. -
 : , — *Euplo-*
tidium itoi
 (*); -
 () ()
 ; — -
 (: Verni and
 Rosati: J. Protozool. 37
 [1990] 337). : a
 580x, 6 6 000x, e
 20 000x, 7 000x,
 2 000x.

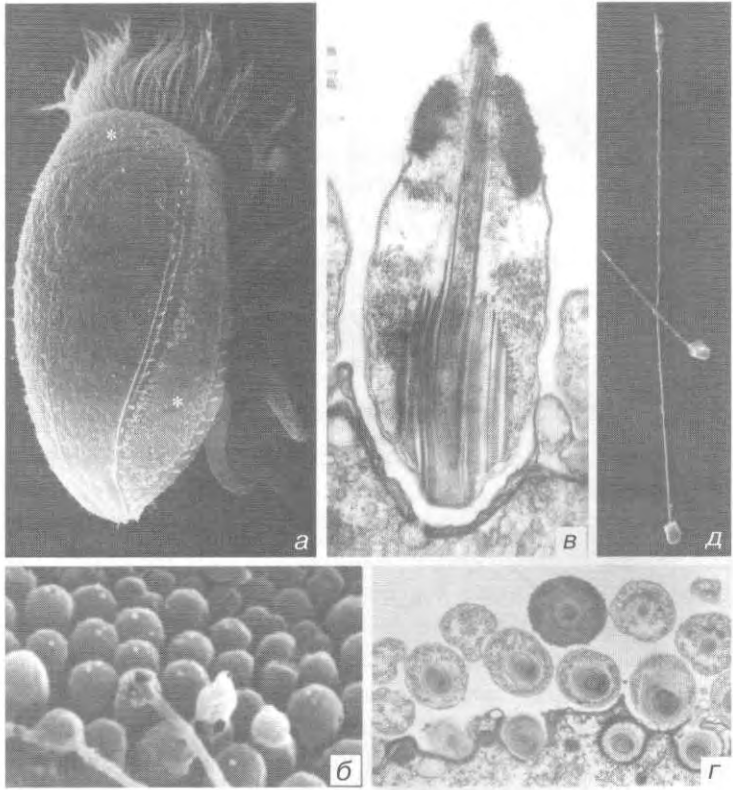

237).

(*Haptoglossa*),

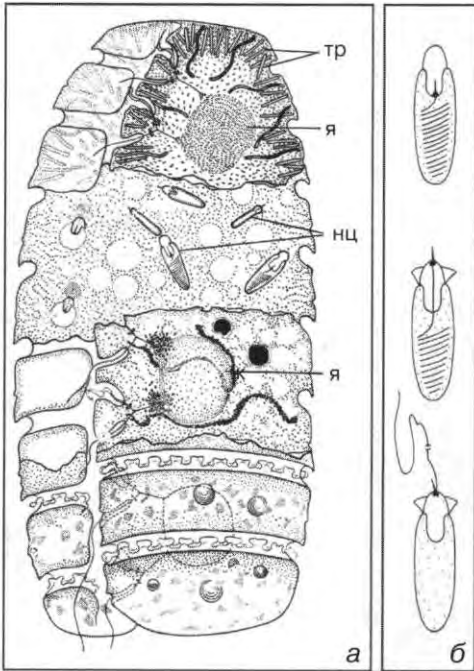

. 238),

(. . 150, 183, 184).

Haptoglossa mirabilis
Adineta

. 237.

Polykrikos.

(1 3) (— : Chatton and

Grasse: . R. Soc. Biol. 100 [1929] 281).

∴ a 600x.

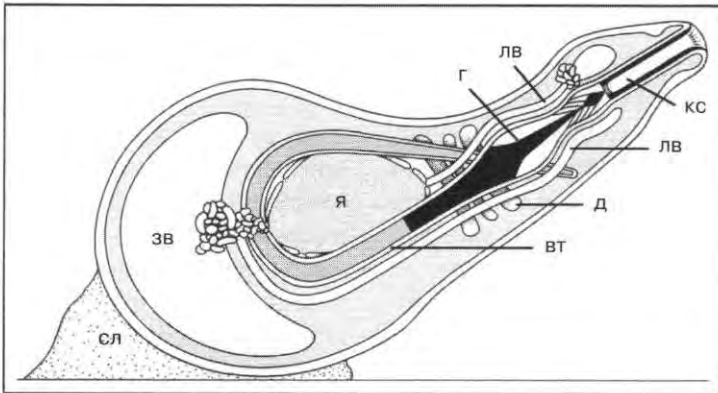

. 238.

Haptoglossa mirabilis.

(. .) . ∴ 6

(. 238).
15

() (. 239),

(),

().

100

— , *Paramecium* (. 240) —

(15 20)

Homalozoon ¹

Dileptus

Loxophyllum Spirostomum,

1

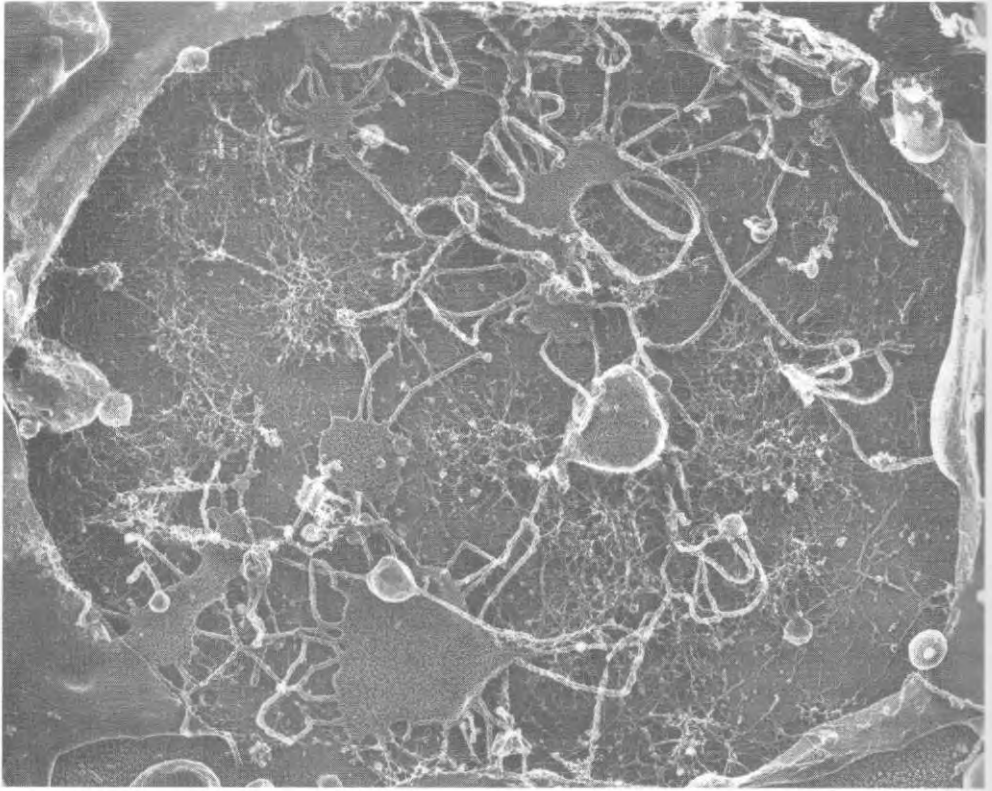

. 239.
Dictyostelium.
[1993] 1311). : 19000x.

(: Heuser et al.: J. Cell Biol. 121

(. 240).

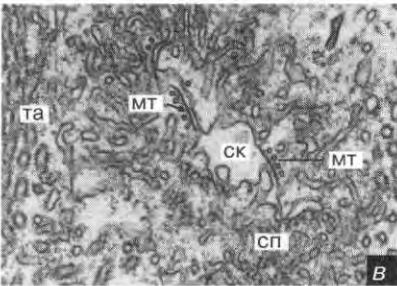
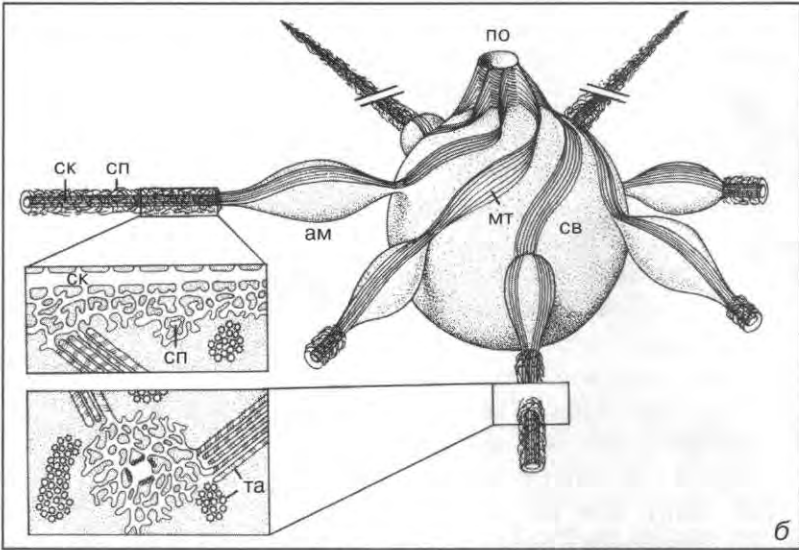
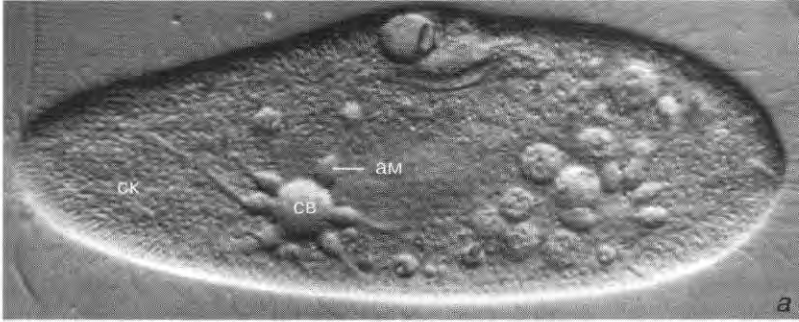

. 240.

Paramecium: — ; — ;
 (), (),
 () ().
 ().
 () () () () — : Hausmann and

Allen: Cytobiologie 15 [1977] 303). : a 650x, —40 000x.

(. 241).

(. 2416).

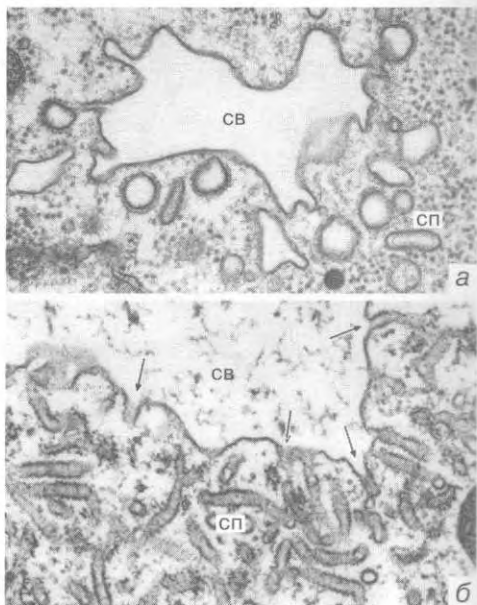

. 241.

()

() *Goniomonas*
() *Pseudomicrothorax* ().

() (— : Hausmann
and Patterson: Exp. Cell Res. 135 [1981] 449:
— : Hausmann: Arch. Protistenk. 127
[1983] 319). . : a 35 000x, б 40 000x.

¹ *Paramecium* (. 240)

[Faint, mostly illegible text on the left side of the page, possibly bleed-through from the reverse side]

Chlamydomonas

[Faint, mostly illegible text on the right side of the page, possibly bleed-through from the reverse side]

(45 117 /)
()
7 />

«

»

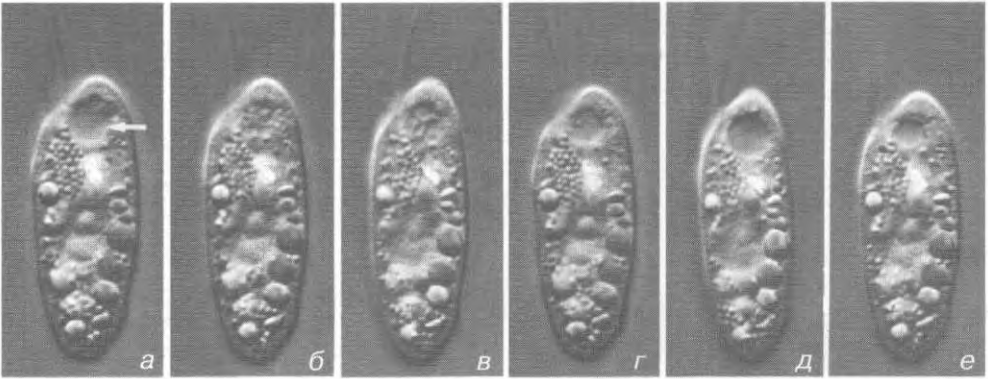

242. () () *Chilomonas*
 () ; 10 () (: Patterson and Hausmann: Br. phycol.
 J. 16 [1981] 429). : a e 3 000x.

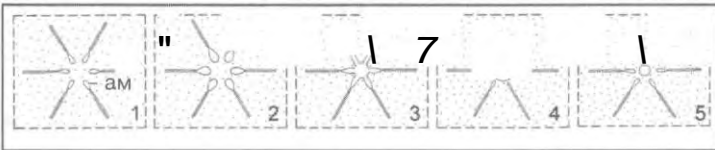
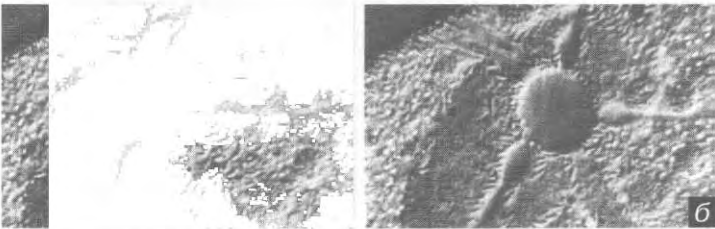

243. -
Paramecium:
 - ; -
 ; -
 (1 5) ,
P. caudatum
 8 -
 , -
 - ; -
 : -
 750 .

(. 244).

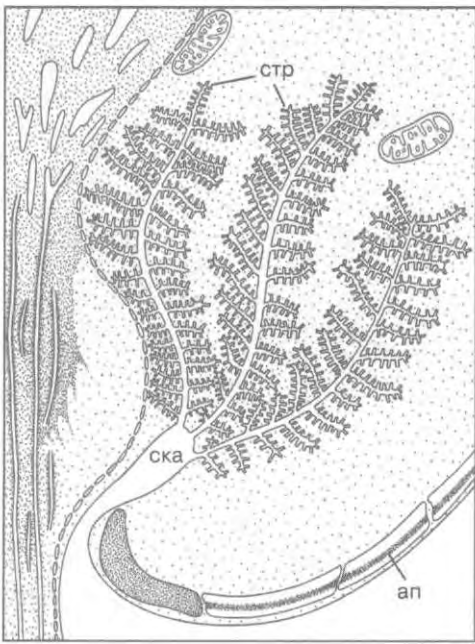

. 244.
Oodinium. an —
 (=)



. 245.
Paramecium

(2,5)

4 * =

245).

0,3

()
(. 246).

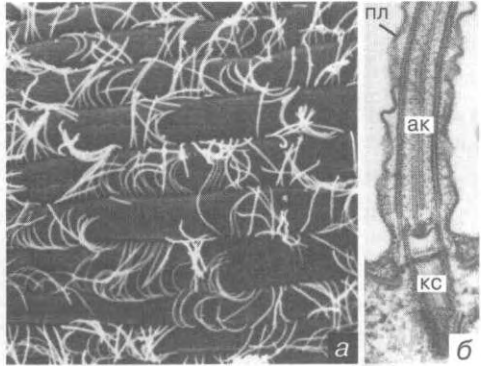

. 246.
Homalozoon ()
Paramecium (),

1 200 , 6 3 2

(. 247).

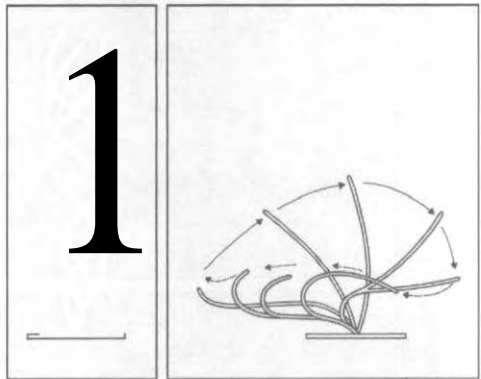

. 247.
() () () .

()¹) 13

9x2+2;

() 10
, 3

(. 248).

()
() .

), (

. 249.

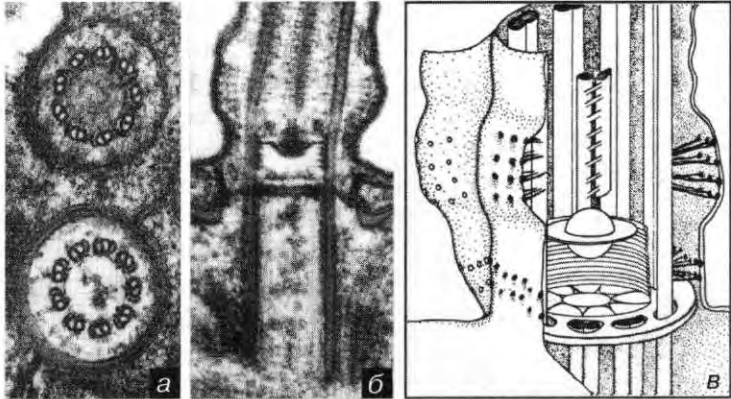

Chlorophyta

() Heterokonta (—
 : Dentler: Int. Rev.
 Cytol. 72 [1982] 1).
 ∴ 6 0 000x.

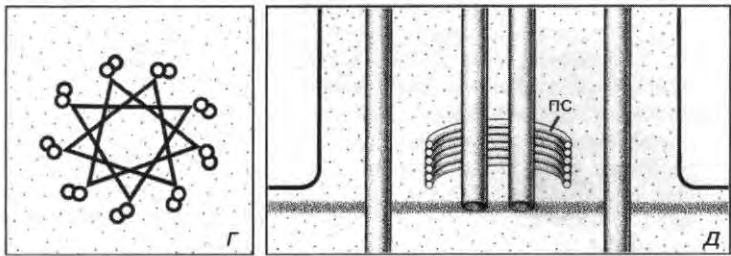

249).

2

3

1

2

3

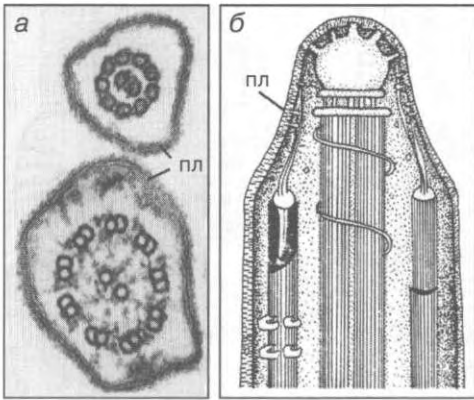

250).

. 250.

Dentler: Int. Rev. Cytol. 72 [1982] 1).
85 000x.

(. 2506).

$$9x2+2$$

0,25 мкм.

$$: 9x2+5, 9x2+0, 6x2+0$$

$$3x2+0.$$

(. 251).

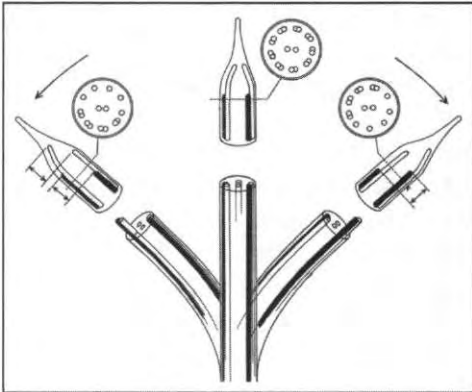

. 251.

() .

(. 252).

()

(+),

40°.

50

2+

+

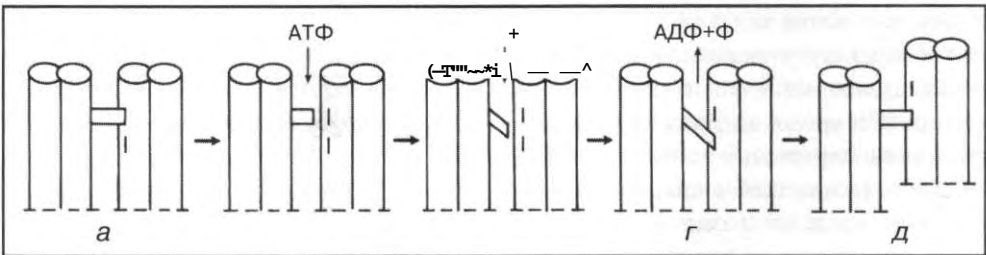

. 252.

40'

()

() .

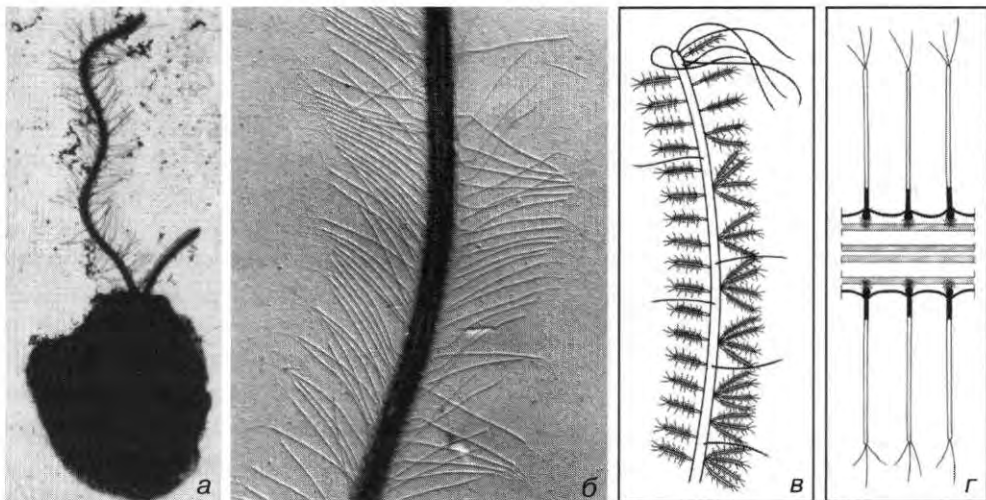

. 254.

Poterioochromonas; —

Paraphysomonas cyllicophora; —

Ochromonas danica; —

(. 255). *Paramecium*

1

2 4

2

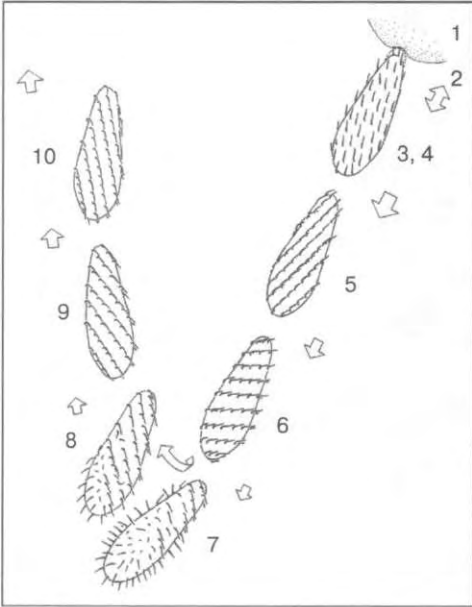

. 255.

mecium,

Para-

Paramecium

Opalina.

Paramecium

(: (4)

(7, 8).

(4 7)

(7, 8) (: Machemer and de Peyer: Verh. Dtsch. Zool. Ges. 70 [1977] 86).

(. 256).

).

()
nophorea

Oligohyme

(. 249).

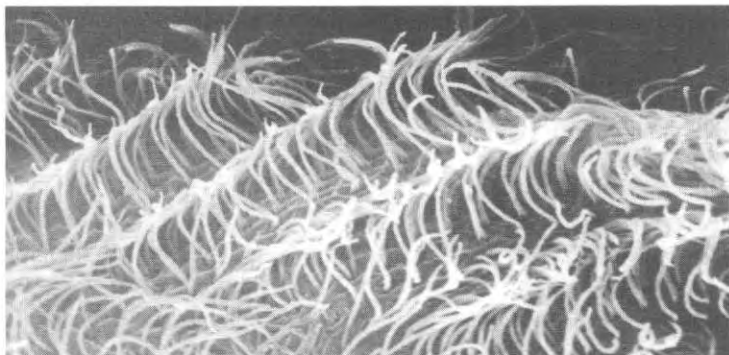

. 256.

Paramecium
 (: Hausmann: Mikro
 kosmos 63 [1974]
 165). : 2 000x.

Mixotricha paradoxa.

Opalina.

(. 257).

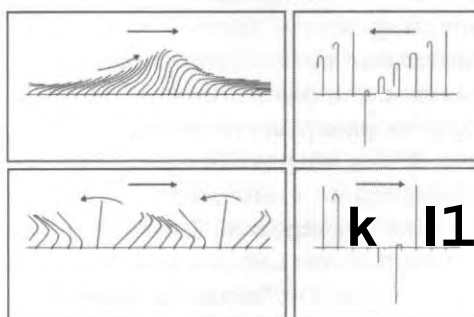

. 257.

().

Opalina *Isotricha*.

mecium.

Para-

Paramecium

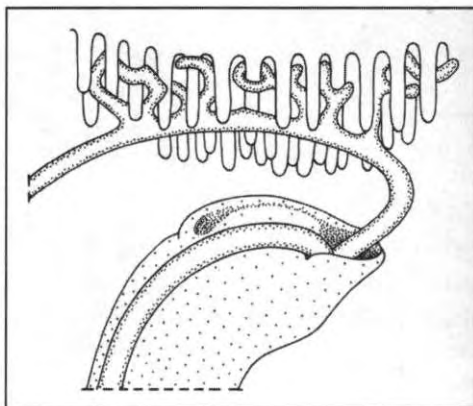

. 258.

Cryptobia

()

(. 258).

(. . 21, 40).

246).

24 , 254)

(. . 168).

(. . 50),

Crypto

Triadopsis *Helix*.

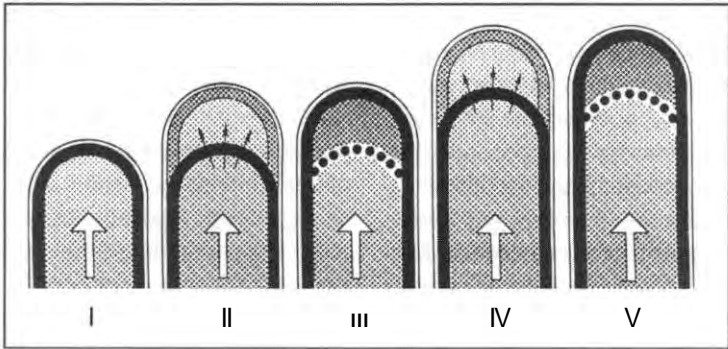
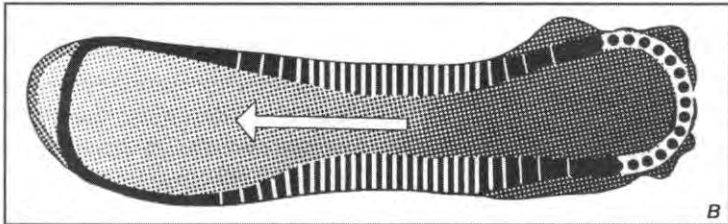
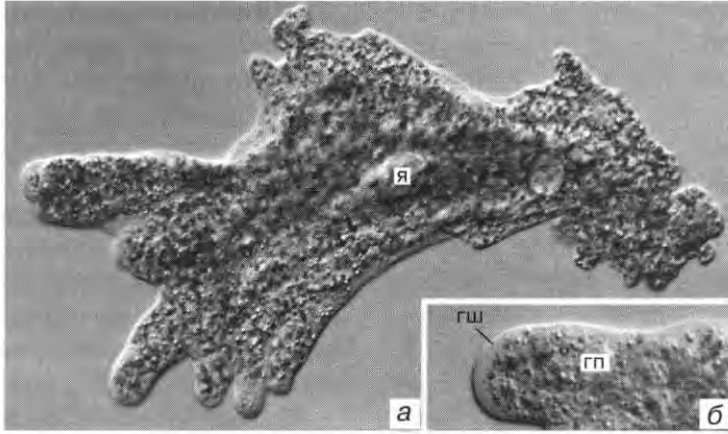

259. : — *Amoeba proteus*. — () . — () ; — (II, IV), (III, V), () (: Stockem and Kloposca: Int. Rev. Cytol. 112 [1988] 137). : a 350x, б 400x.

8

0,5).

F

Physa

(I,
II),

(

Physarum.

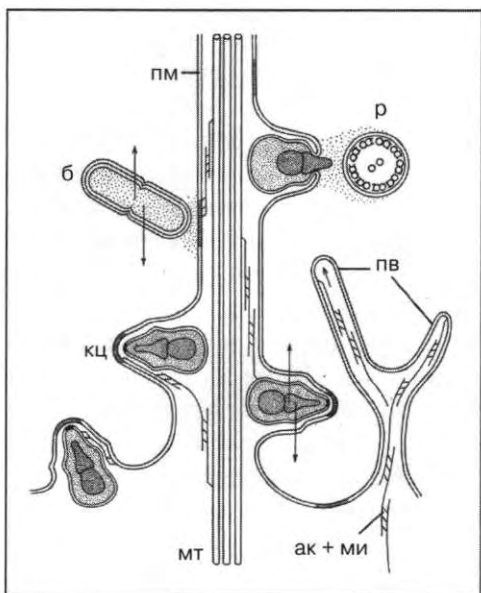

Physarum

2*

27

. 260.

() .

() ,

Actinopoda

(. 260).

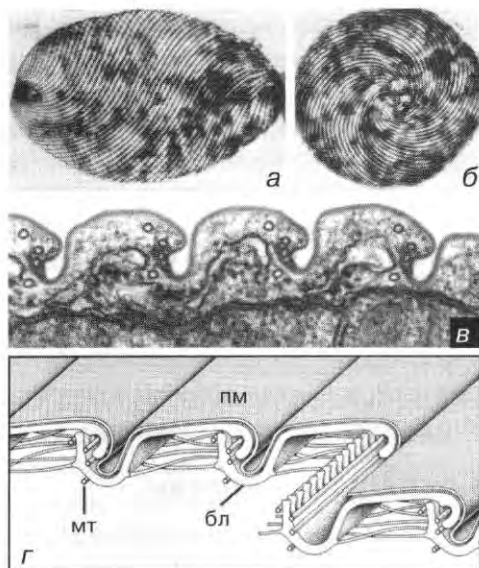

261). *Distigma*

. 262.

Euglena; —

; — *Astasia longa*; —

(— : Foissner: Acta biol. Acad. Sci. Hung. 28 [1977] 157; —

). . : — 720 , 65 .

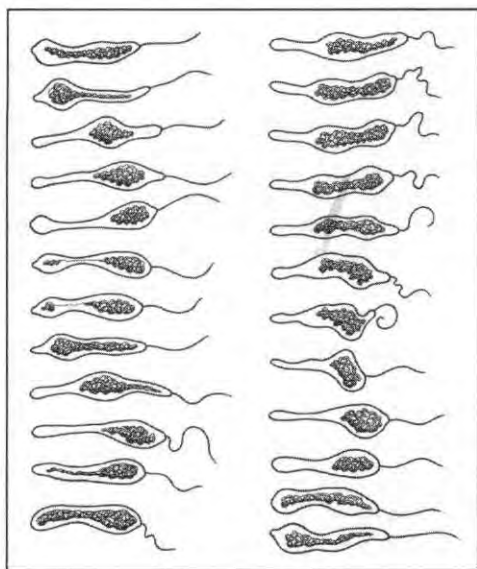

. 261.

() *Distigma*.

— 2 —

(: Hausmann and Hulsmann: Photo Med'4[1981] 253).

(. 262).

Distigma

, *Stentor*

5 10

() ,

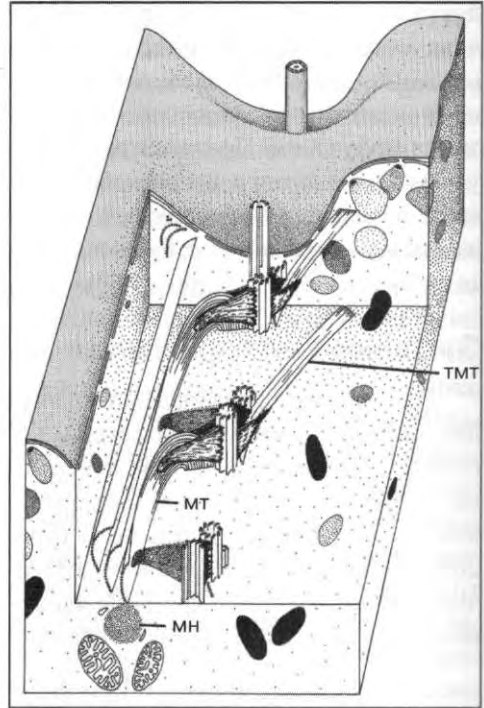

. 263.

Eufolliculina.

() —

() —

(: Mulisch et al.: Protistologica 17 [1981] 285).

4

(. 263).

() ,

(10 12)

Heterotrichea.

()

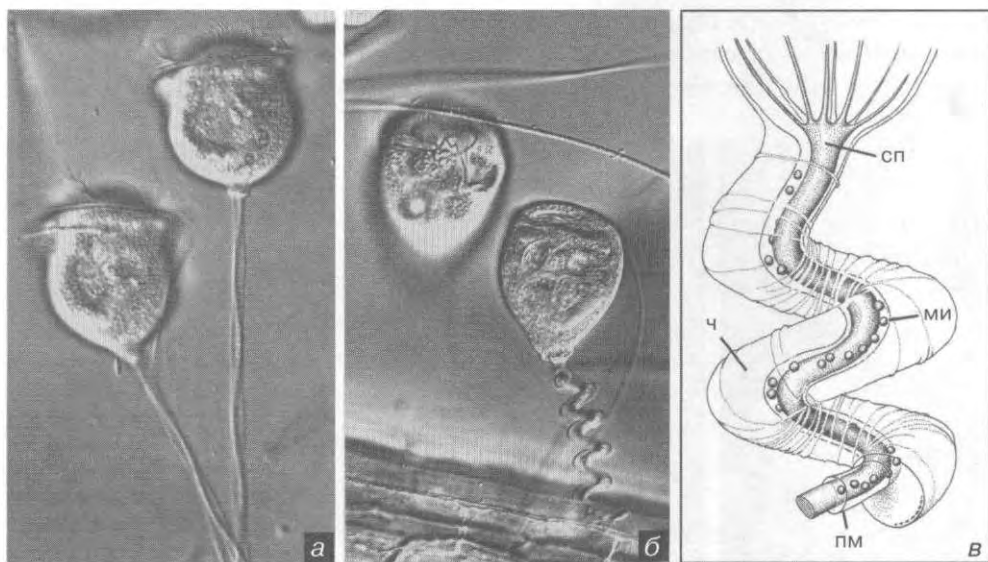

. 264.

Vorticella ()

(); ():

(), — ; —

(— : Kleinig and Sitte: Zellbiologie, Stuttgart 1992; —

). : — 220 .

(. 264).

2

3 ()

Vorticella

1

5 7

(. 265).

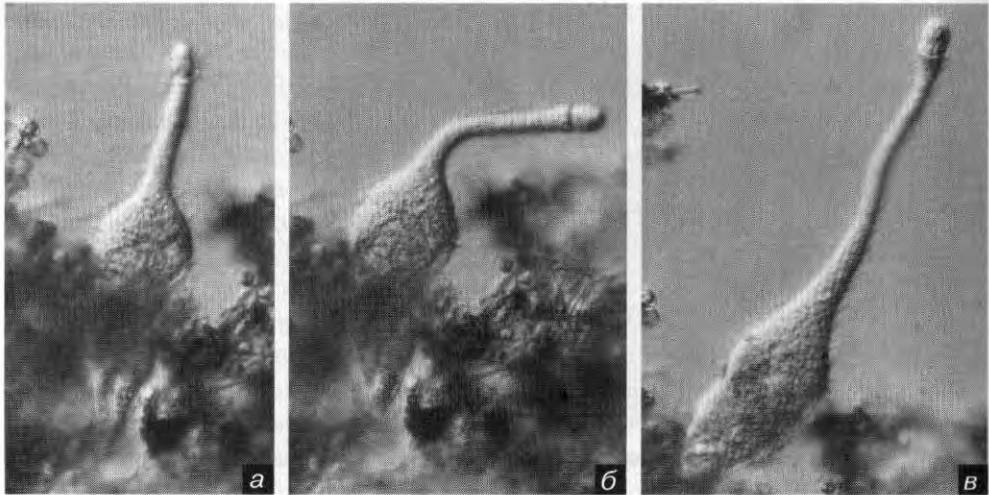

. 265.
Hausmann: Mikrokosmos 76 [1987] 176).

Lacrymaria olor () (:

— 200 .

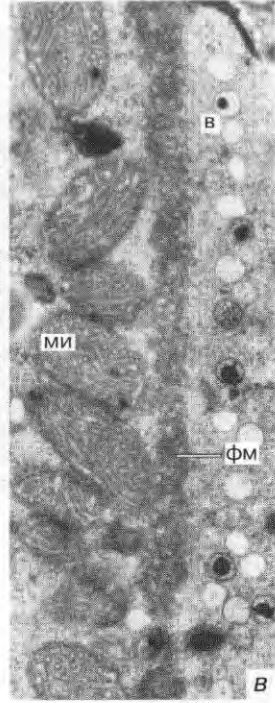
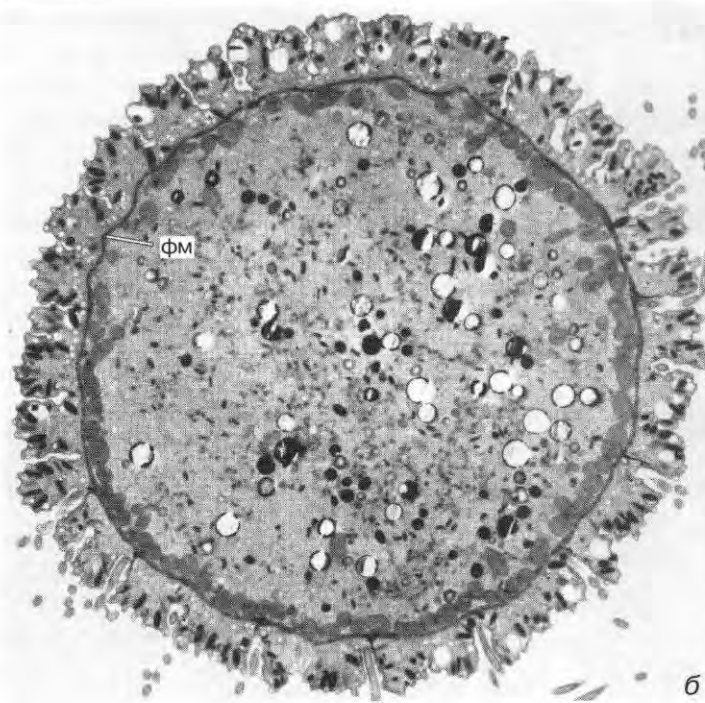
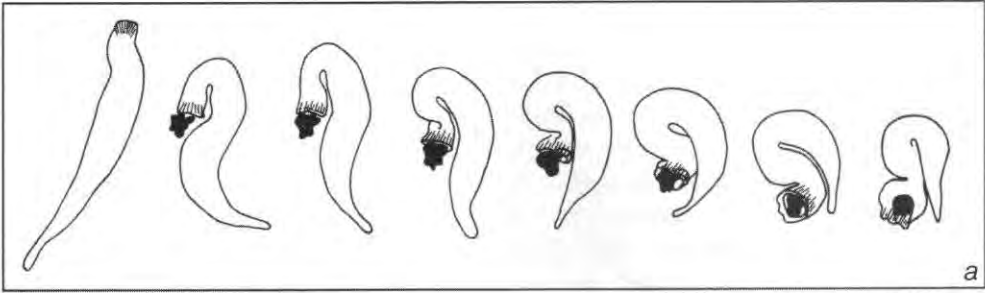

266. (); , — Homalozoon (), — (: Kuhlmann et al.: Protistologica 16 [1980] 39). : 6 5 500x, — 30 000x.

(. 266).

267).

(. 267) .

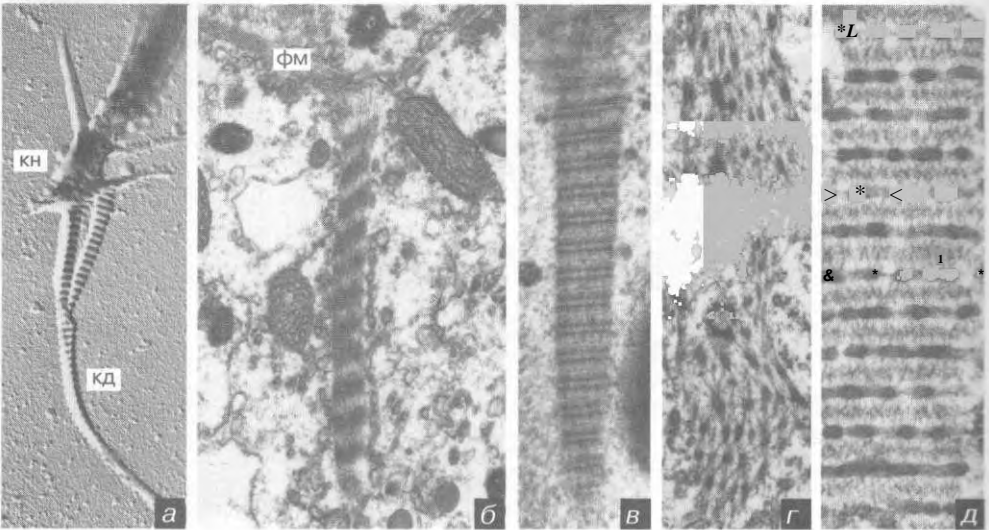

. 267.

Chilomonas; —
 Trichodina. : 25 , 6 2 0 , — 60 , 30 , 65

Loxophyllum; —

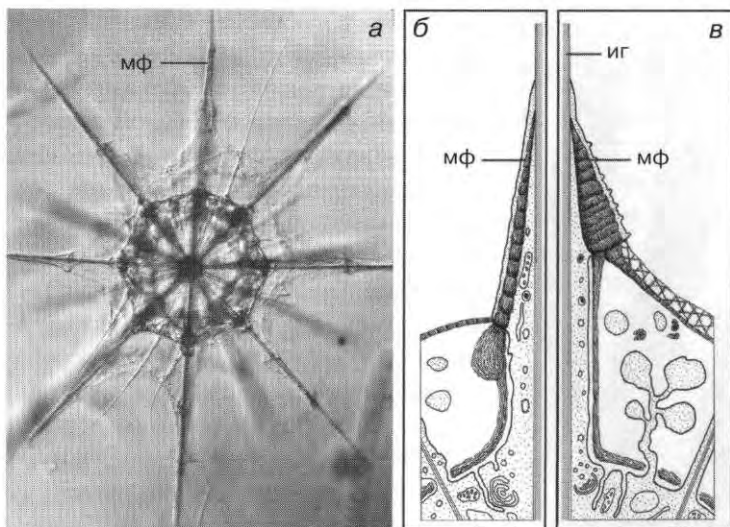

. 268.
 () ()
 (), -
 () -
 () -
 (-
). ∴ - 160 .

() Acantharea,

(. 268).

Noctiluca scintillans.

Paramecium

(. 111).

Trichodina,

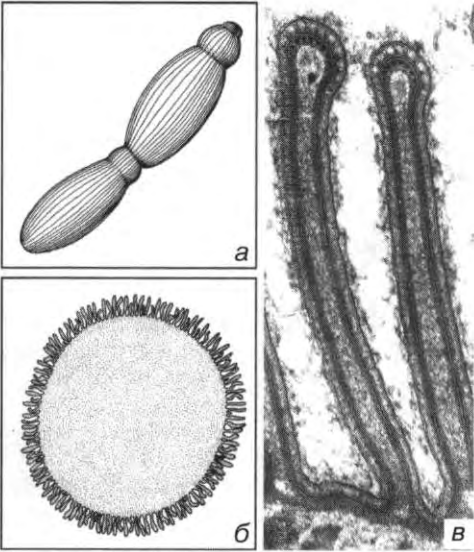

. 269.

() ; —
Gonospora beloneides
 (—) . : 48

(. 269).

Plasmodium ()

(throm
 bospondin related anonymous protein —
 TRAP),
 Apicomplexa. TRAP

, TRAP

),
 (. 270),

(. . 174)

1

2

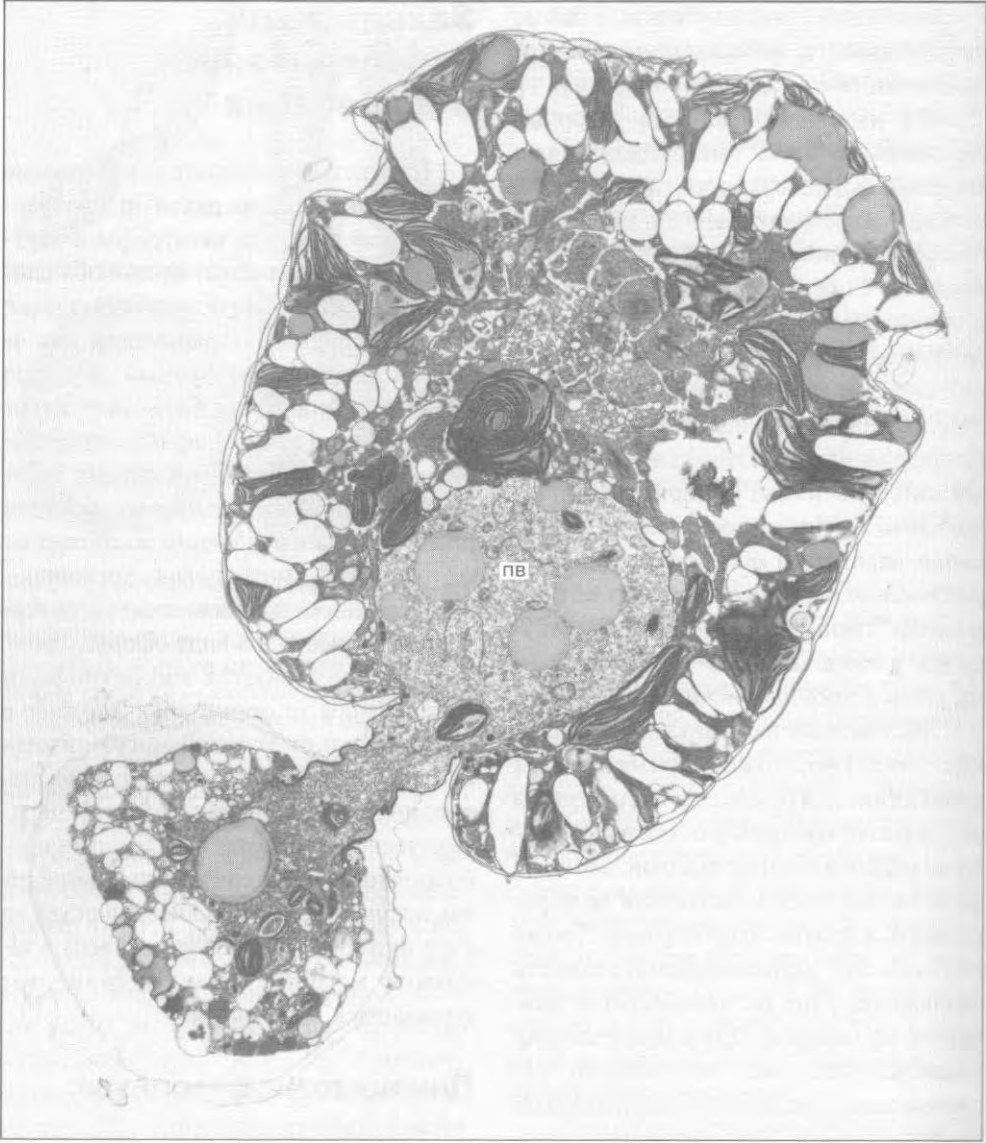

. 270.
27 [1981] 600). : 4 000x.

Amphidinium cryophilum,
(: Wilcox and Wedemayer: J. Phycol.

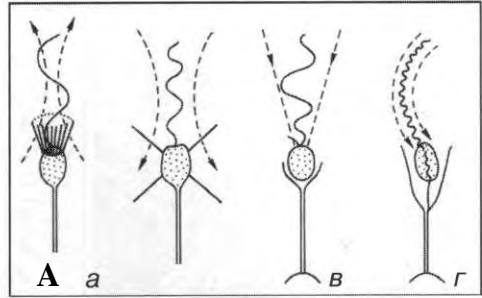

273.

nosiga, — Actinomonas, — Ochromonas,
— Bicosoeca. ()

273 276).

274.

Prymnesiomonada

(. 277; . 60).

274.

Opisthokonta

Cafeteria roen

bergensis () Bodo saltans ()

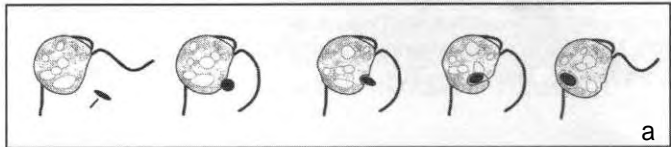

()

{Cafeteria} {Bodo}

Spumella sp. ()

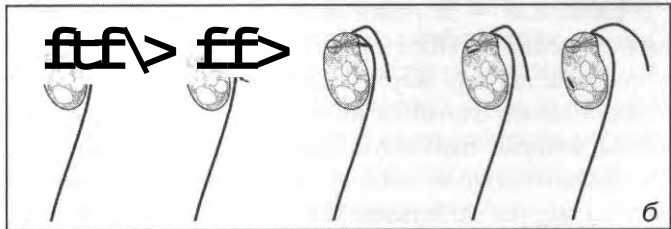

(: Boenigk and Arndt: J. Eukaryot. Microbiol. 47 [2000] 350).

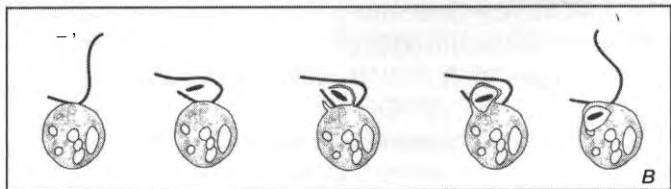

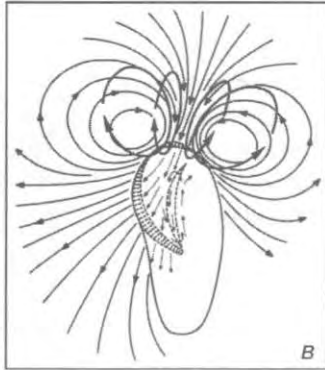
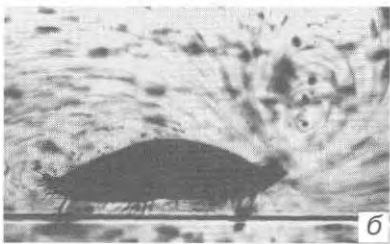
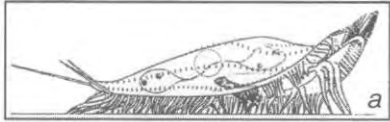

. 275. -
 Sty
 (,
 lonychia:
)
 ().

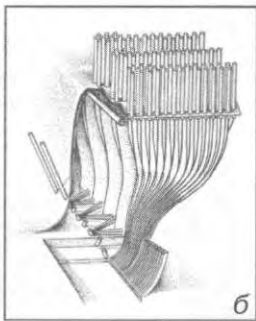

1
 (. 279),
 (. . 131).

. 276. *Eufolliculina*, -
 ()
 (),

(: Mulisch and Hausmann: Protistologica 20
 [1980] 415). : a 70x.

Pseudomicrothorax

5
Oscillatoria

(. 280, 281).

(. 278).

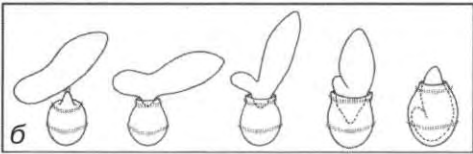
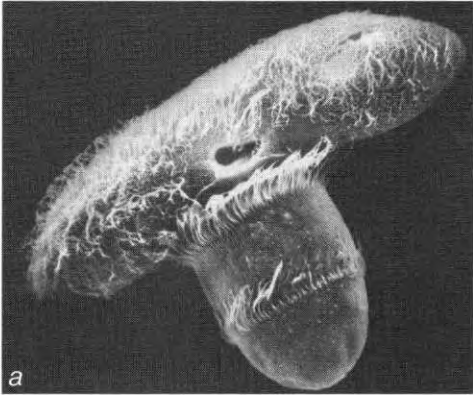

278. *Didinium nasutum* Paramecium (—). : — 290 .

Grossglockneria Pseudoplatyophrya,

Gymnodinium, Paulsenella Peridiniopsis.

Aconchulina

(*Gobiella, Hyalodiscus, Lateromyxa, Vampyrella*)

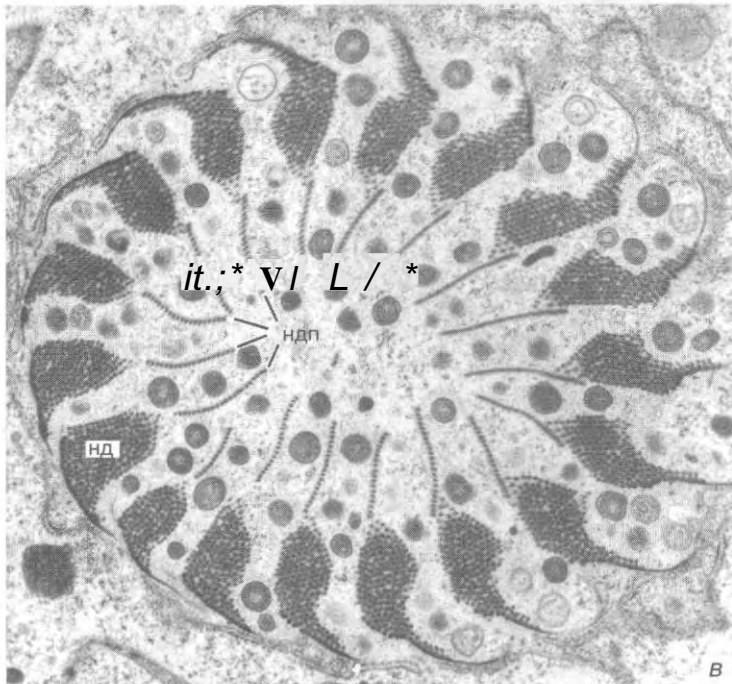
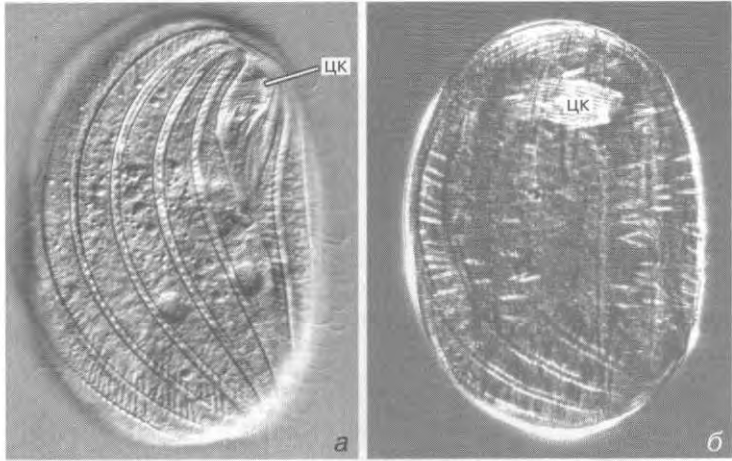

.279. ()
Pseudomicrothorax
 (), -
 () -
 (). -
 , -
 ()
 () (),
 (: Hausmann and Peck: Differentiation 11 [1978] 157). :
 800 , — 15 .

(*Oedogonium*, *Spirogyrd*),

283).

(.

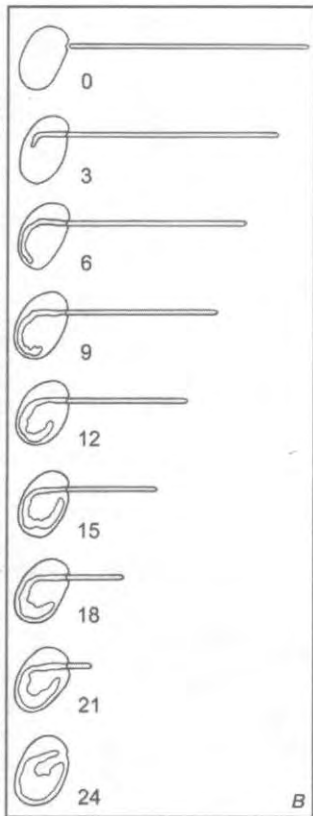
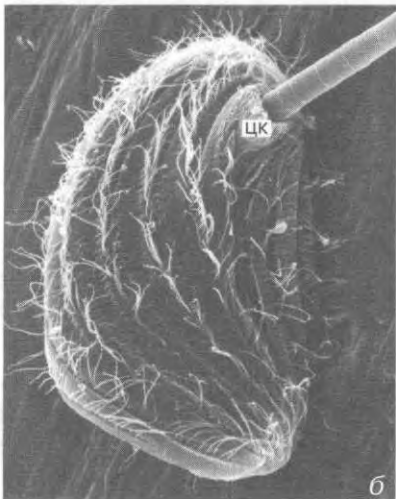
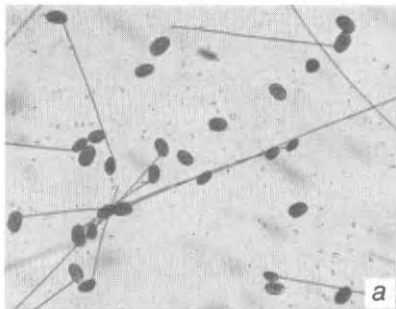

280.
Pseudomicrothorax
Oscillatoria. —
 — *Oscillatoria*
 (),
 ; —
 5 (:
 Hausmann and Peck:
 Differentiation 14 [1979]
 147). : a 40x,
 1 000x.

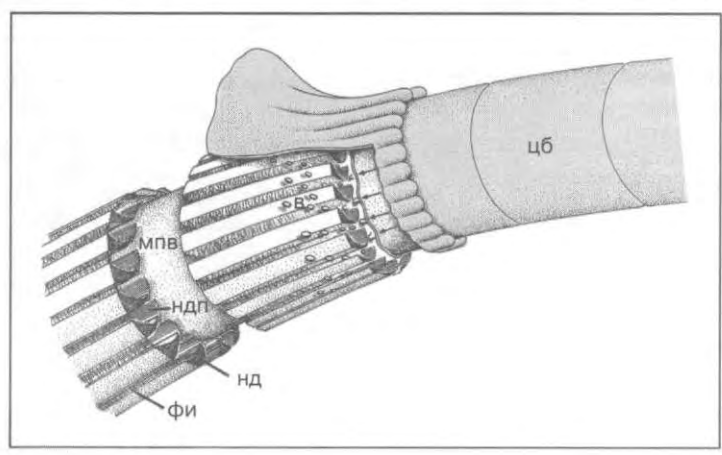

281.
Pseudomicrothorax
 () ()
 () —

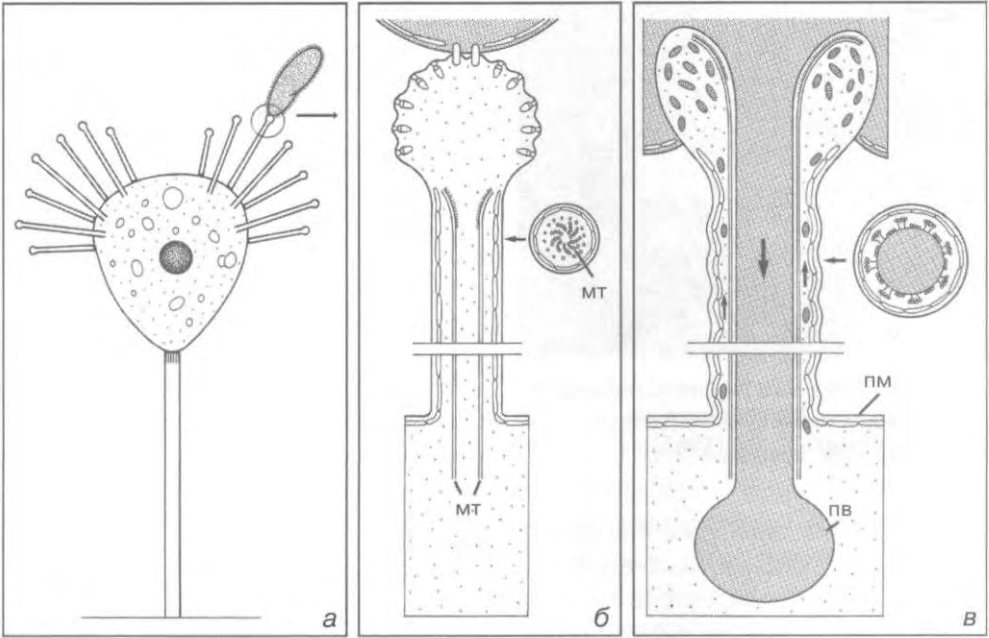

. 282.

();

: ()

()

()

(),

() (), —

(, ,).

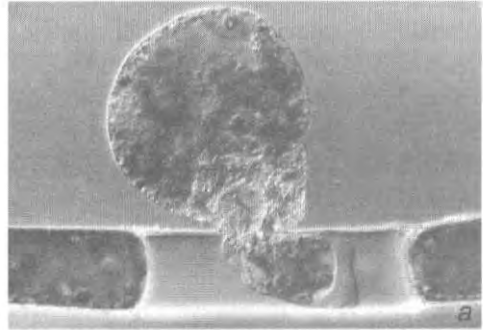

a

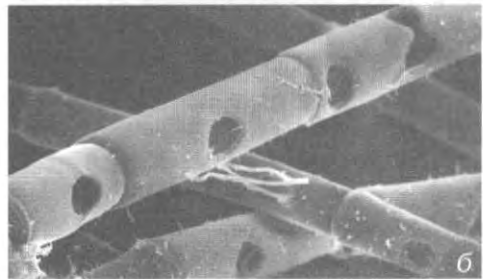

б

. 283.

— *Hyalodiscus*

Oedogonium; —

Gobiella

Oedogonium. ∴ —

400 ,

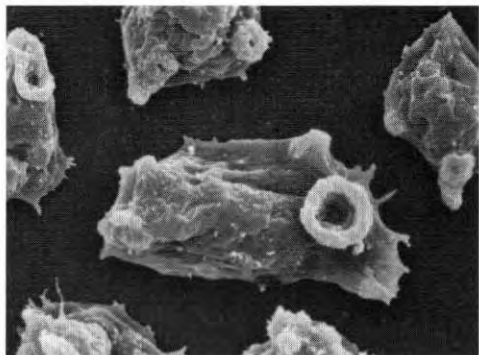

284. *Naegleria fowleri*
 () (: John
 et al.: J. Protozool. 32 [1985] 12). :
 1 800x.

(. 284).

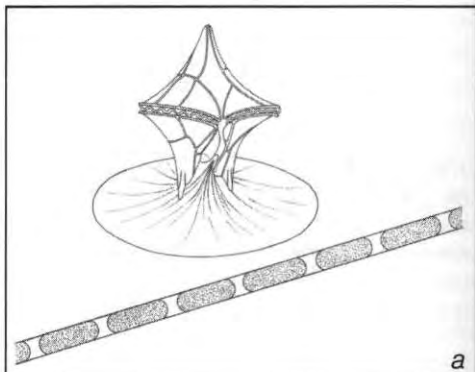

a

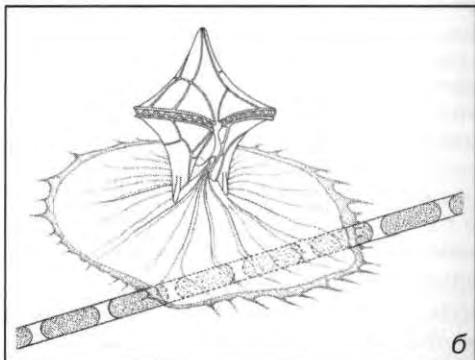

b

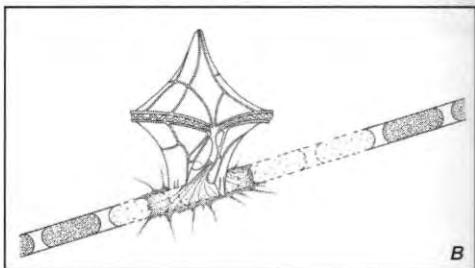

B

Protoperidinium conicum

(. 285),

(

).

20 30

. 285.

Protoperidinium

conicum.

(),

()

() (

). : 400 .

, *Trichonympha*).

215). (. . . 102, 103, 111,

(. . .)

).

(. . . 279),

(. . . 286).

(15 /)

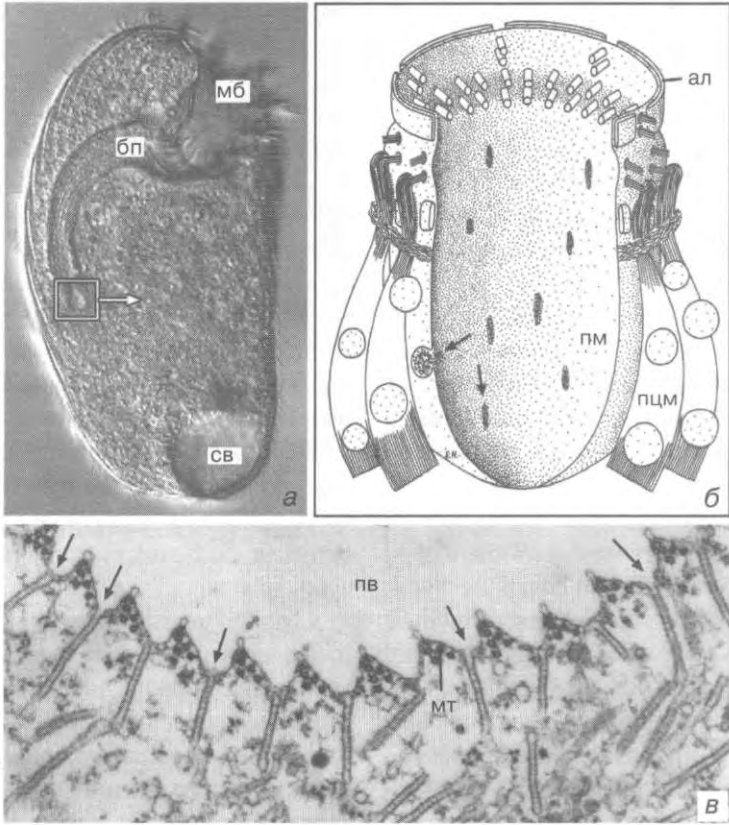

286. : , — *Climacostomum*
 () ()
 ()
 ()
), — , —
 ; — ()
Trichodina. — (— : Fischer Defoy and
 Hausmann: Differentiation 20 [1981] 141; — : Hausmann and Hausmann: J. Ultrastruct. Res.
 74 [1981] 131). . a 500x, 55 000x.

Pseudomicrothorax dubius

Pseudomicrothorax

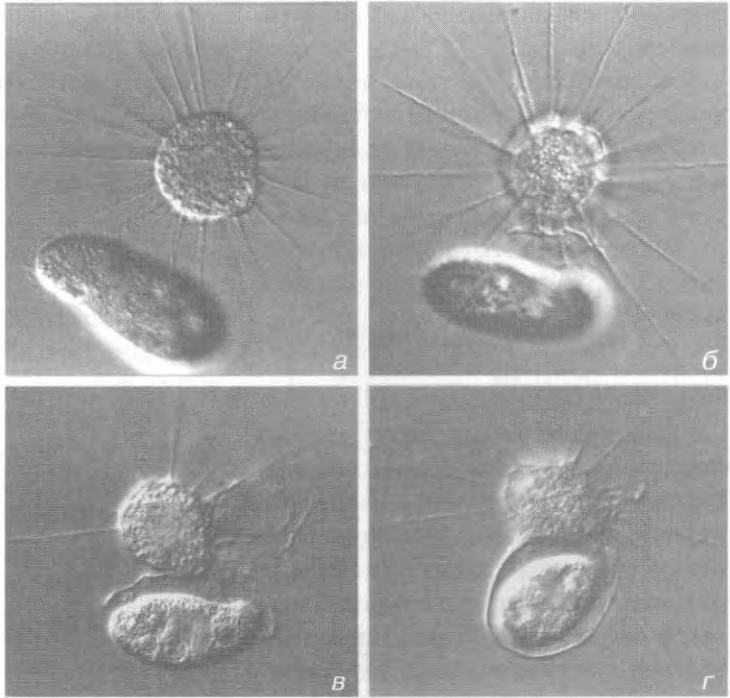

. 287.
Actinophrys sol -
 () -
Colpi
dium (). -
 15 -
 (: Hausmann
 and Patterson: Cell
 Motil. 2 [1982] 9).
 ∴

. *Actinophrys sol* -
 (. 287).

15

()

20

(. 289).

Paramecium.

I (1).

(. 288).

15

6

1

0,1

0,4

0,8

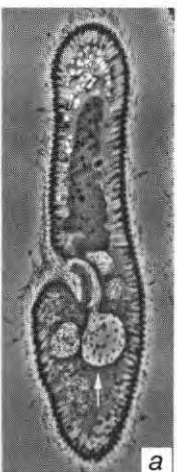

a

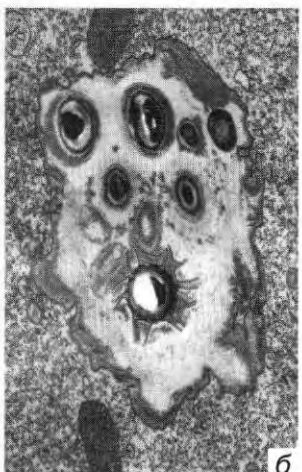

b

. 288.

Paramecium.

() ,

(-

, -) .

13 000 .

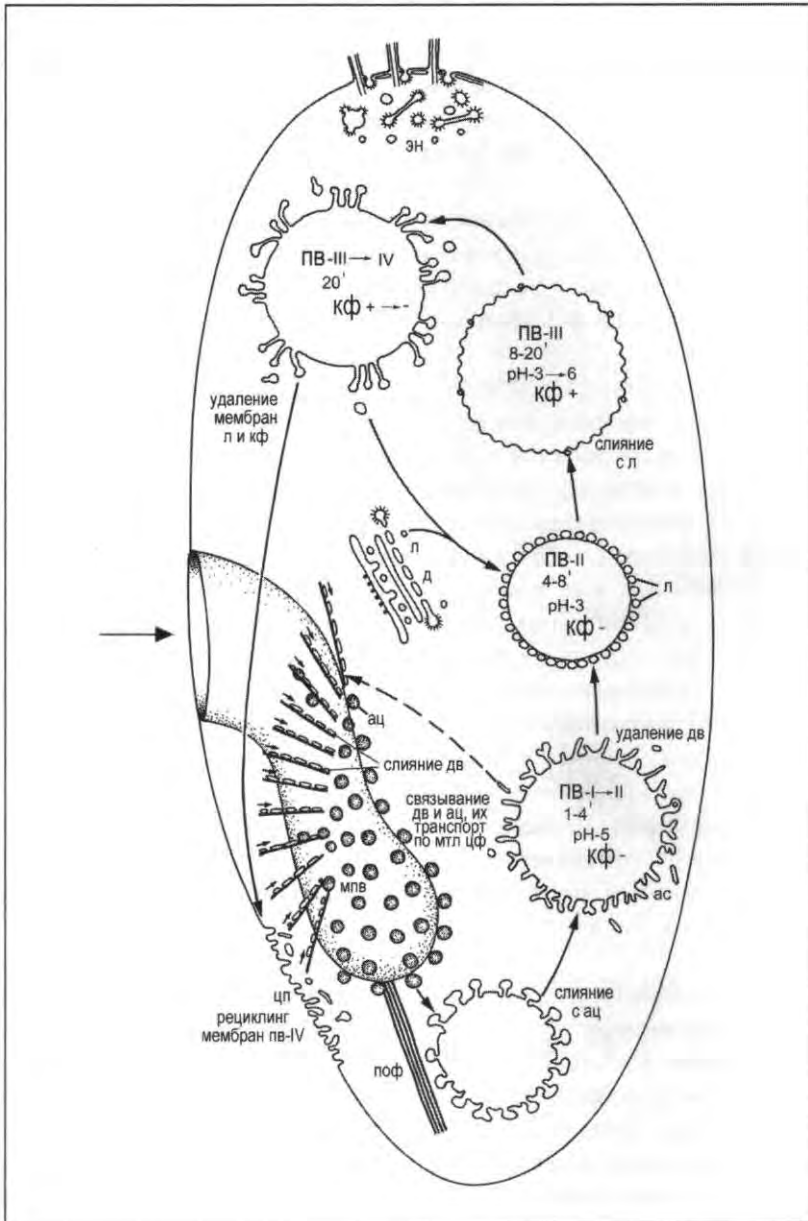

. 289.

Paramecium,

1— IV —

()

1 -

1 . -

6 , 1 -

() . - () .

() -

1. -

(,)

0,2 0,4 -

1, -

() ,

() ,

IV.

1

mecium,

Para-

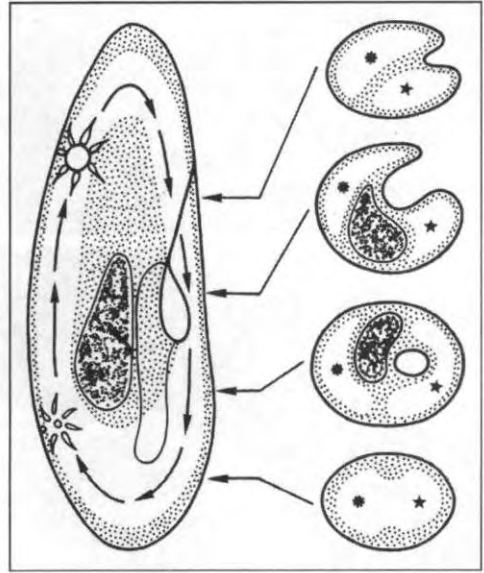

. 290.

Paramecium

mecium

Para-

290).

()

() 2 3 ()

3

(. 291).

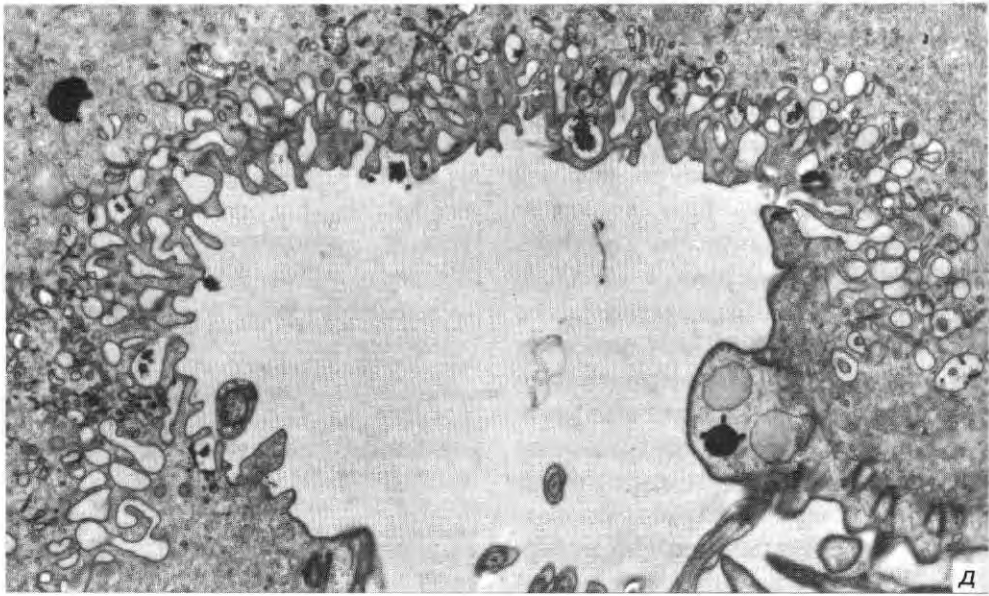
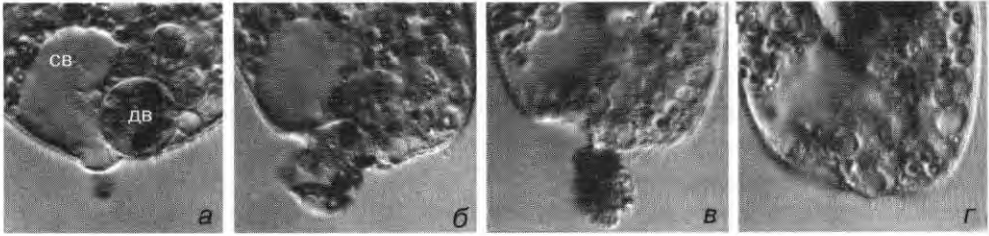

291. *Climacostomum*. — ()
). — ()
).
 (: Fischer Defoy and Hausmann: Zoomorph. 100
 [1982] 121). : — 470 , 13 000 .

()
 (. 292).



Рис. 292. Схема функционирования цитопрокта у *Paramecium*: приближение дефекационной вакуоли к цитопроктору (а, б) и везикуляция мембраны дефекационной вакуоли после слияния с поверхностью клетки (в, г) (по Аллену и Вольфу).

Microspore¹, *Entamoeba*,

(. 291, 292).

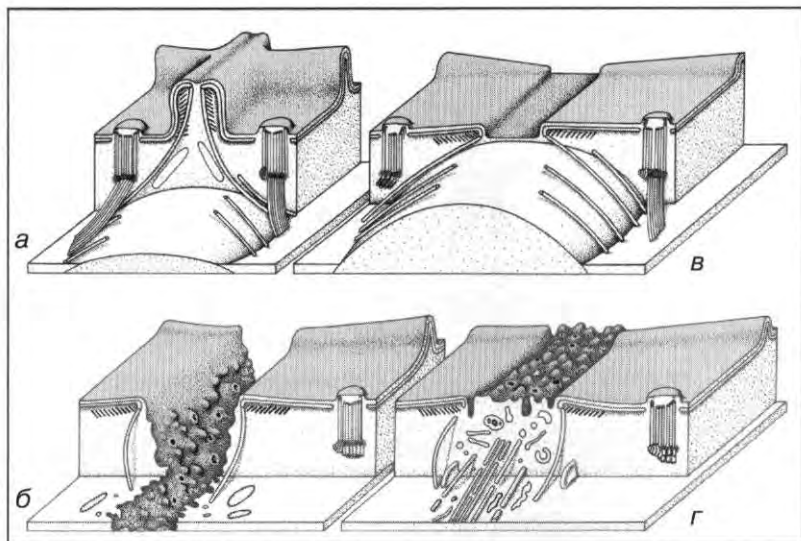
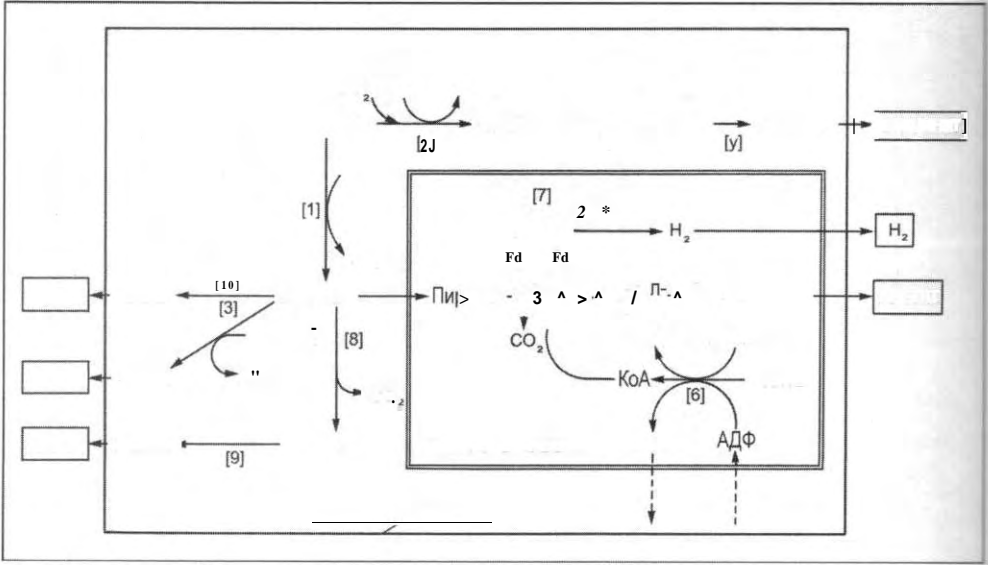

293.

Trichomonas vaginalis *Tritrichomonas foetus*.

(), [3] , [1] , [2]
 , [5] / , [4] , [7]
 [8] , [9] , [10] (*Trichomonas vaginalis*), [] (*Tritrichomonas foetus*), []
 (*Tritrichomonas foetus*), [Fd] (: Miiller, 2002).

02, (. 293).

0

02.

I (, *Giardia intestinalis*, *Entamoeba histolytica*)

basalea) II (15).

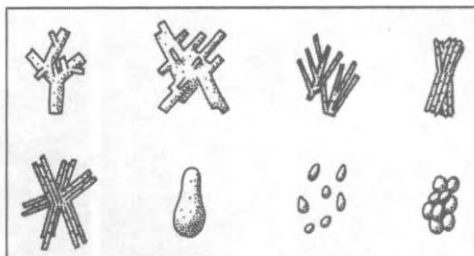

294. *Paramecium* ().

02 2.

5

Paramecium tetraurelia

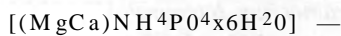

294),

1

Paramecium,

()

(. 296)

Chaos, Pelomyxa, Actinosphaerium, Opalina

(, Api

complexa)

Coccidia,

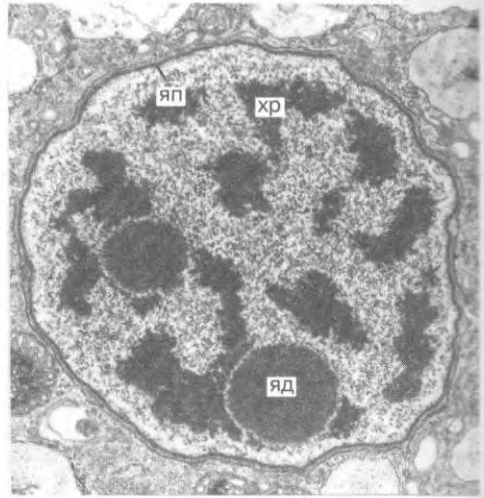

. 296. *Lateromyxa gallica* (Vampyrellidae)

15 000 .

Peridinium balticum)

(. 112, 113,

297)

()

(, *Rotalliella*

heterokaryotica; . 162).

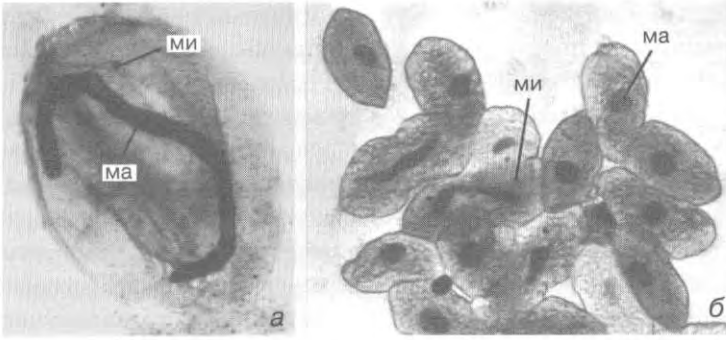

297. -
Euplotes ()
Tetrachymena ()¹
 -
 -
 -
 -
 -
 500 , 200 .

100 * .

(. 7, 18, 296)

proteus

(. 296). *Amoeba*

(. 298), —

phrys)

(, *Actino*

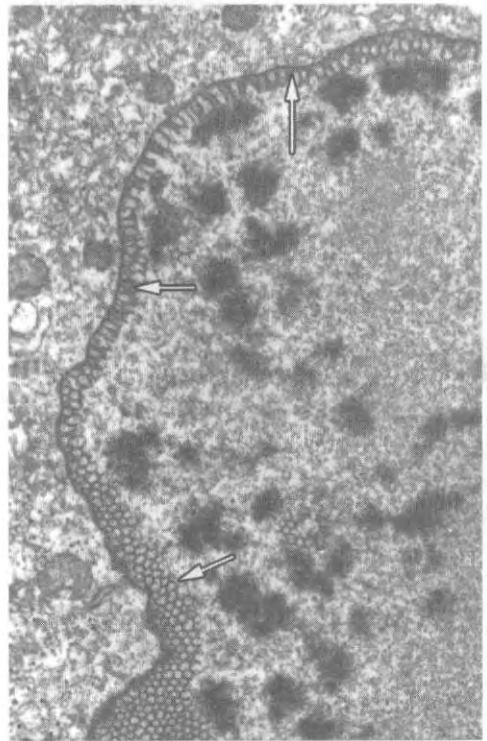

298. ()
Amoeba proteus ()
 ,). : 12

1

2976 —

*

600 . —

(. 296).

Apicomplexa

(, *Barbulanym*
pha, Trichonympha)

Tetrahymena.

(Vol
vocida,
, Apicomplexa),
(
Actinophrys, Noctiluca)

().

1,

(

. 2).

hymena thermophila 10 20

5%

1
Paramecium caudatum *Paramecium aurelia*
)

-
-

(. . . 321).

(S)
G, G²,

() ().

-
-
-
-
-
-

Parame-
cium S

Paramecium

(. . . 299).

(. . .)

).

-
-
-

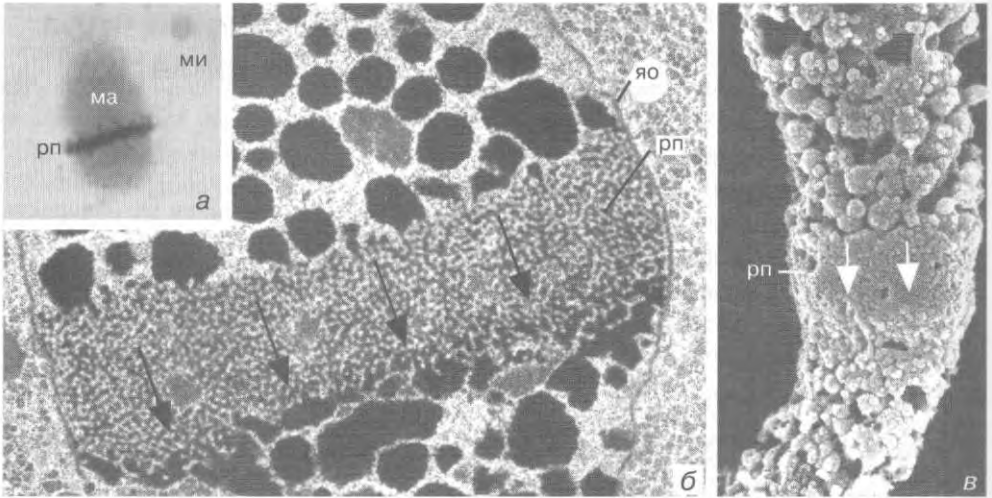

299. () () *Stylonychia* () () *Euplotes* () ()
), — (— : Steinbruck: *Europ. J. Protistol.* 26 [1991] 2; —
 40). : а 650x, б 13 500x, — 7 000x.

(. 300).

Monocystis)

(()

)

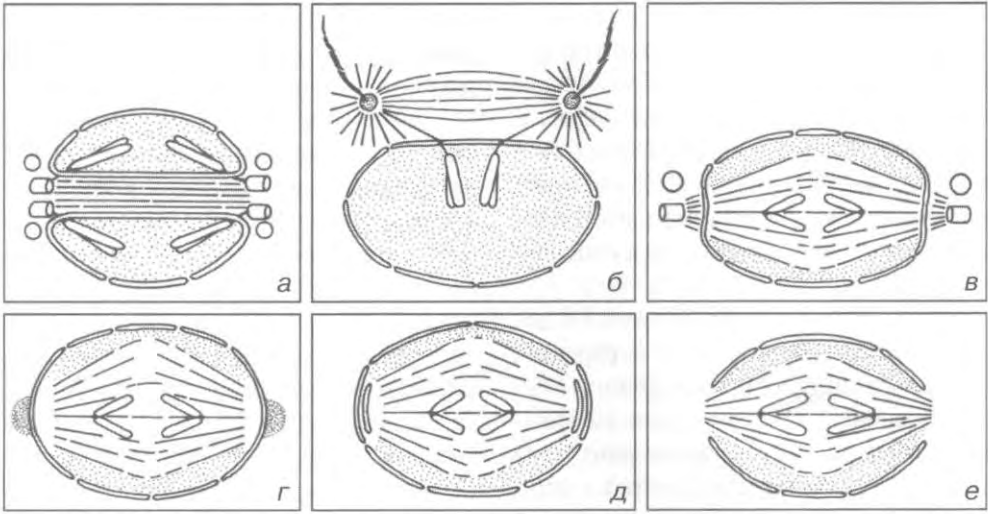

. 300.

(
 () ; —
 () ; —
 () ; —
) () .

(Volvocida)

(*Amoeba proteus*),
 (*Monosiga ovata*),
Deplauxis)
 (, *Actinophrys*).

Apicomplexa.

{*Euglypha*, *Arcella*},
 , *Arachnula*, *Lateromyxa*, *Vampyrella*)

(, *Trypanosoma cruzi*)
 () , () ,
 . *raiae*)

Stentor

I

(. 301).

, *Bursaria*, *Paramecium*),

()

I

(I).

, *Urostyla grandis*.

, *Homalozoon*

to cruzia

(*Arcella*, *Lateromyxa*

gallica),

(*Amblyospora*),

Myxozoa (*Aurantiactinomyxon*),

(*Prorocentrum*),

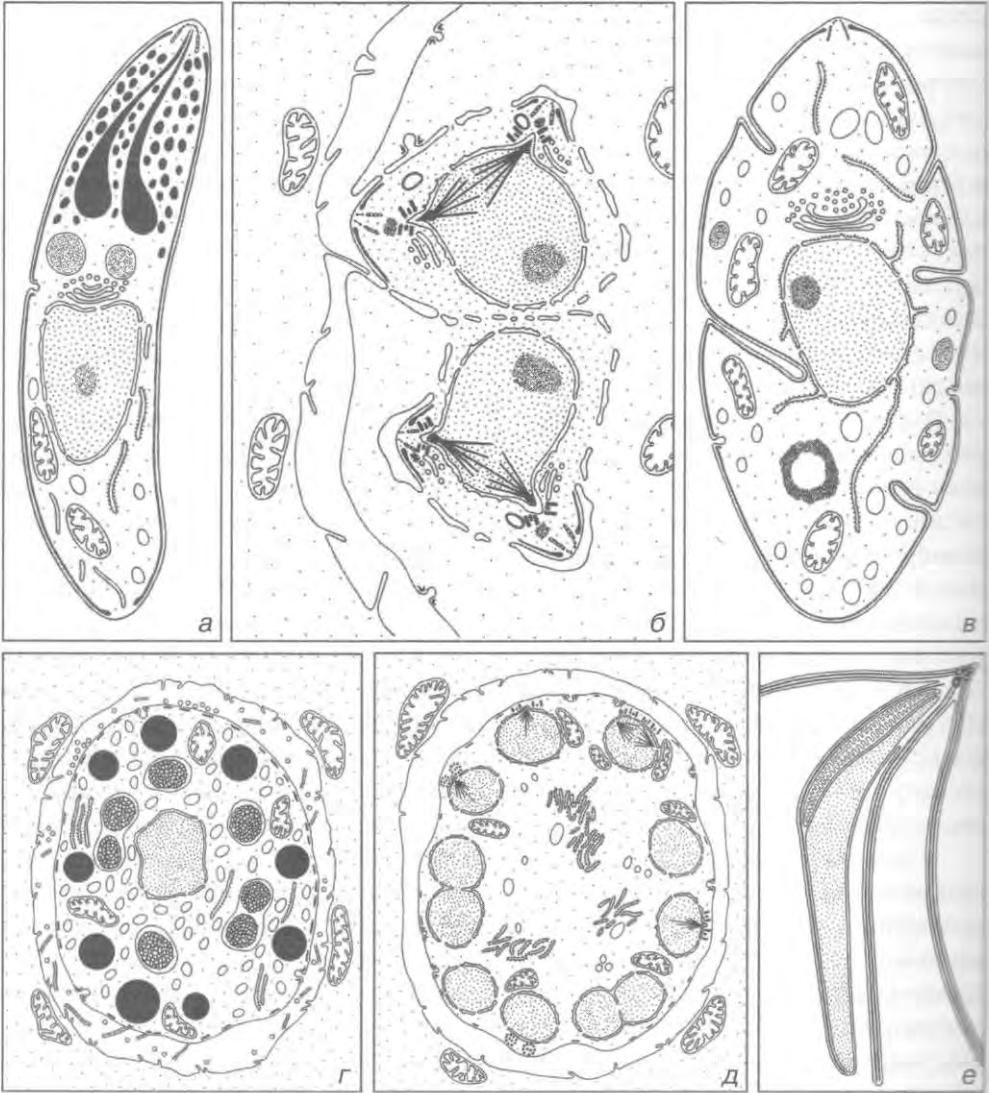

. 303.

— ; — ; — ; — ; —
 — ().

Apicomplexa:

— /ОНТ;

Apicomplexa

(. 303), -

(-

),
 СТ-
 СТ-
 СТ-
 СТ-
 СТ-

plexa

Apicom-

(. 3036).

phrys sol
(. 304)

Actino-

(. ,),

Arcella.

Opalina ranarum (. . 64)

(*Elphidium crispum*),
(*Glabratella sulcata*)
(*Rotaliella*).

(. 646).

Apicomplexa.

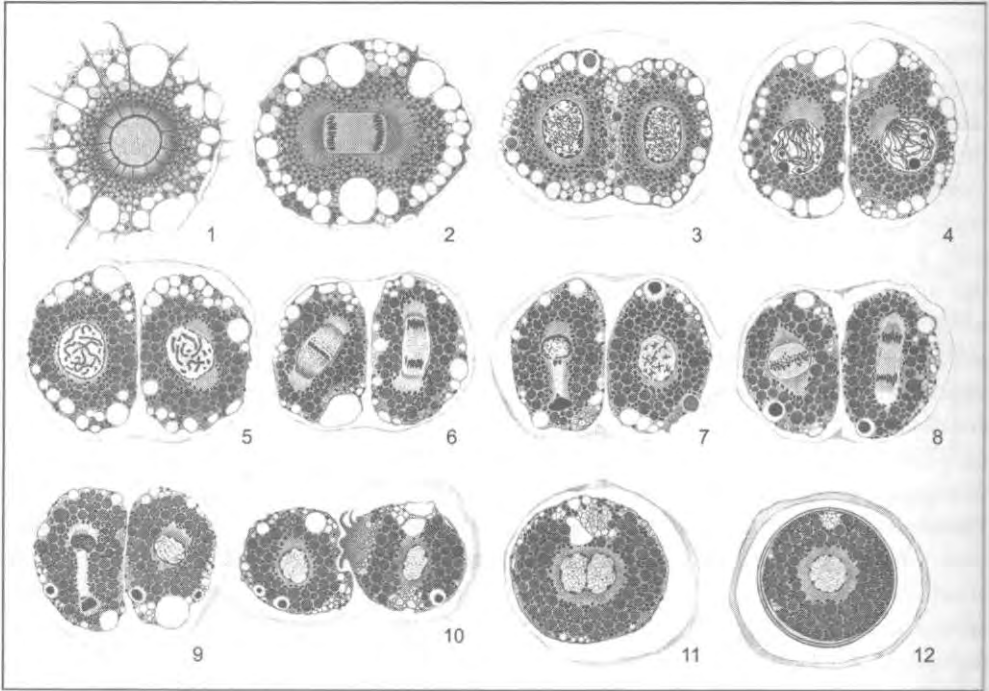

304. (=) *Actinophrys sol* (1); (2 9)'; (10) (11) (12) (). : 540 .

) ,
(-
)² (. 305). -

Foraminifera. *Hetero*
stegina depressa

1

Actinophrys sol

: 2 3 —

; 4 7 —

; 8 9 —

2

(),

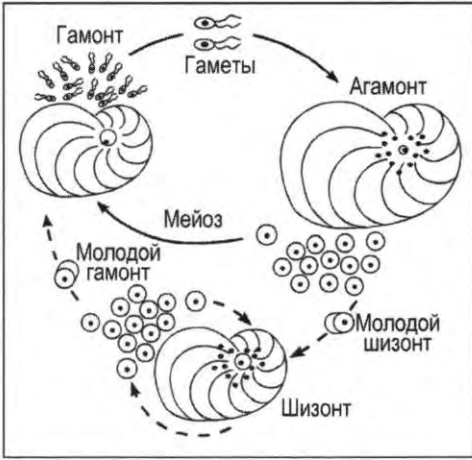

. 305.

()

()

Hymenomonas carterae

, *Cladophora*).

(. 306)

Paramecium cauda
tum 16

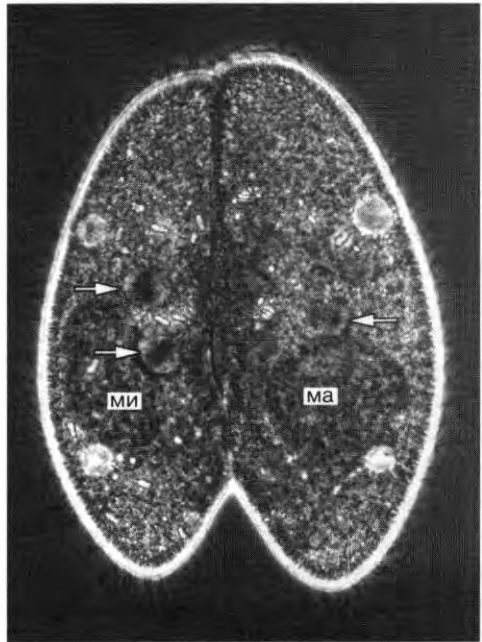

. 306. *Paramecium cauda*
tum: ()

()

.: 350 .

crassus, Tetrahymena thermophila)

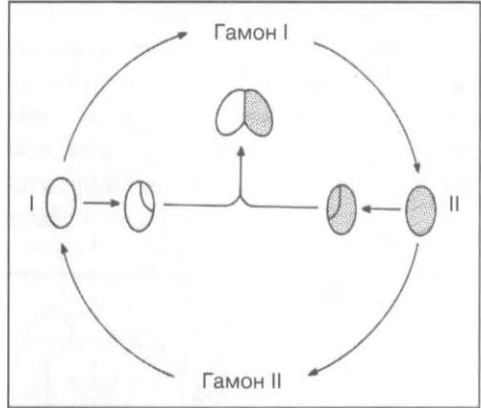

307. *Blepharisma*

Paramecium

caudatum

3

(306).

I, II, I ()

II;

G, R²,

II

G² R^r

Euplotes octocarinatus

10

G⁴,

(G., G², G³,

(R, R², R³, R⁴).

(1) « *Blepharisma japonicum*,

Blepharisma

japonicum

(G¹⁵ G²),

1 2
3 4,
GP G², R³, R⁴;

R., R², R³, R⁴.

(R_j, R²).

I

I

(2)

() .

Euplotes raikovi.

()

raikovi

Euplotes

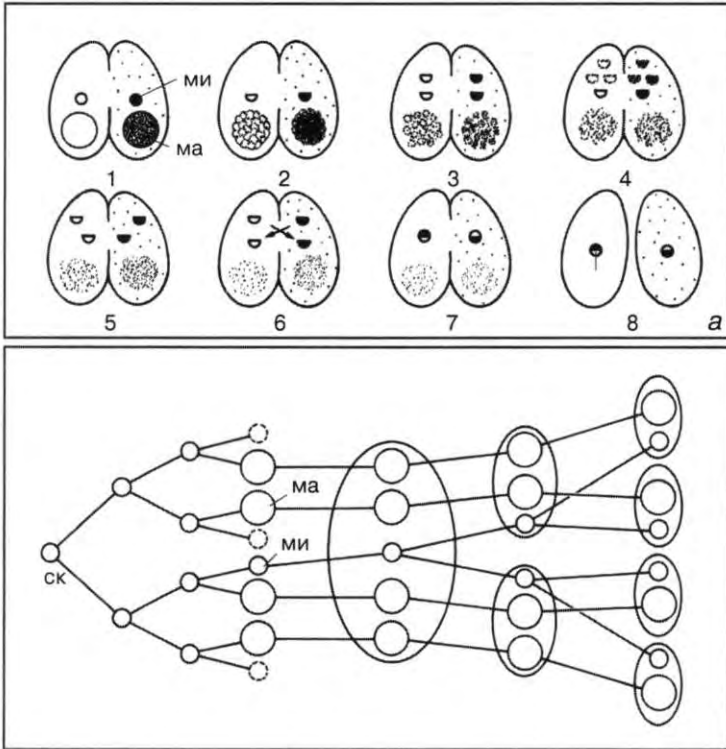

308.

Paramecium caudatum ():

() (2 4);

) (5);

(6),

(7);

()

1,

(8)

() .

() .

(
)
(. 308).

(, -
, -
, -

Paramecium

()

(. 3086).

()

1

1

« »
« Ciliophora: «

» — , , ».—

()

sea, Myxogastrea, Dictyostela; . 56, 179, 180) Sorogena (. 226)

(. 309).



. 309.

Paramecium

(, Apicomplexa),

(: Iftode et al.: Development 105 [1989] 191). : 600x.

	-	(<i>Stentor</i> , <i>Fabrea</i> , <i>Blepharisma</i>)	-
	-	(<i>Epistylis</i>),	-
	-	<i>Hyalophysa chattoni</i>	-
	-	<i>Euplotes muscicola</i> .	-
	-	<i>Lateromyxa gallica</i> ,	-
	-		-
	-		-
	-	<i>Naegleria gruberi</i>	-
	-	(-
	-	<i>Acantha</i> 80%),	-
<i>moeba</i>	-		-
	-		-
	-		-
	-		-
S	-		-
	-		-
	-	<i>Acanthamoeba</i>	-
	-	(-
	-)	-
	-	<i>Euplotes</i>	-
	-	, <i>Pseudomicrothorax</i>	-
	-		-
	-	<i>Bursaria</i>	-
	-	, <i>Colpoda</i>	-
	-		-
	-		-
	-		-
	-		-
	-		-
	-	<i>Colpoda</i>	-
	-		-
	-		-
	-	<i>Giardia</i>	-
<i>lamblia</i> ,	-		-
<i>Actinophrys sol</i> ,	-		-

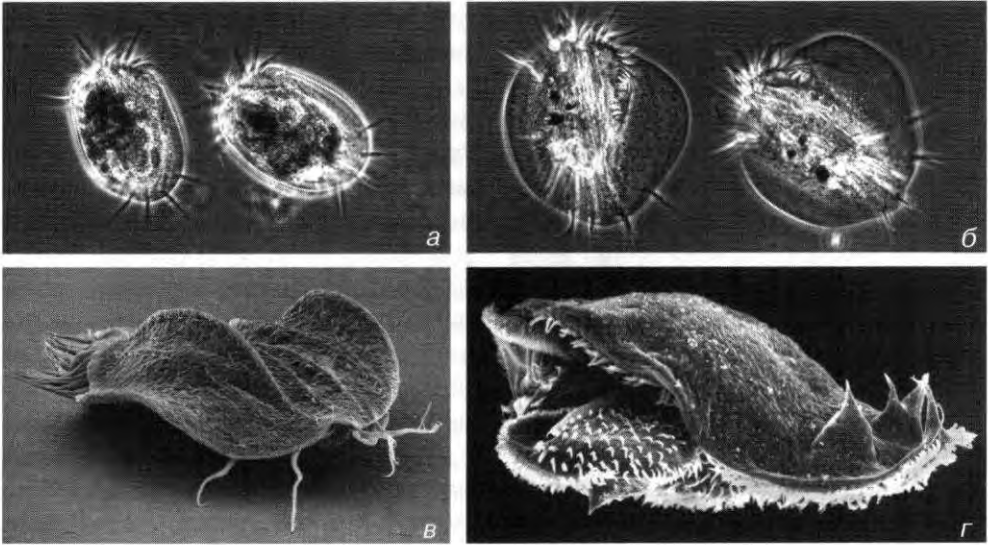

311. *Euplotes octocarinatus* (Lembadion) —
Onychodromus quadricornutus (Lembadion) — Kuhlmann and Heckmann: Science 227 [1985] 1347;
 Wicklow: J. Protozool. 35 [1988] 137. 270, 760, 280.

Euplotes
 (311).
Lembadion *Euplotes*
octocarinatus
 (3116),
Euplotes.
Naegleria
Tetramitus

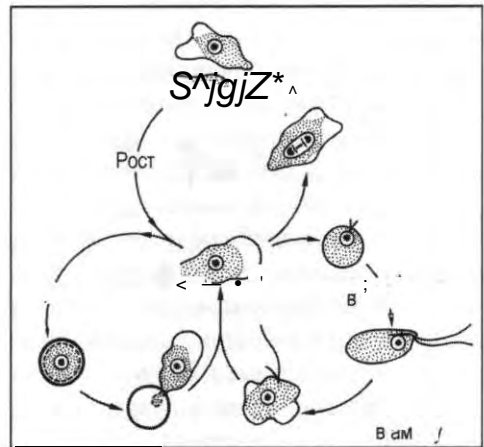

312. *Naegleria gruberi* (Naegleria)

()

Clathrulina elegans

()

(. . 210).

Naegleria

Suctororia (. . 130, 131)

Tetramitus,

)

(. . 118)

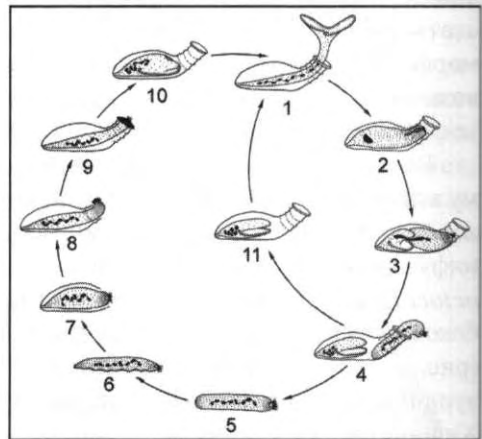

. 313.

Eufolli

culina uhligi: 1 — , 2 4 —
5 — , 6 10 —
, 11 —

(: Mulisch and Patterson: Protistologica 19 [1983] 235).

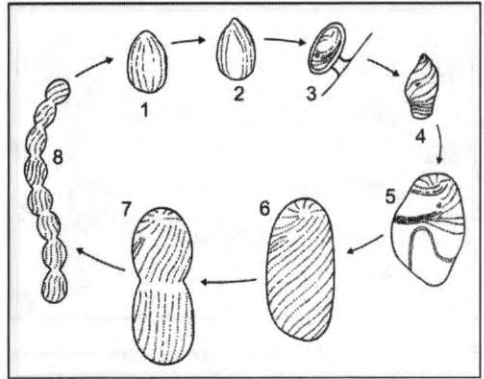

. 314.

Polyspira delagei: 1 —

, 2 —

, 3 —

, 4 —

, 5 —

, 6 —

, 7-8 —

() ().

Spirophrya subparasitica

Zoothamnium alternans *Z. arbus*

cula (. 144).

()

(. 313).

(. 220),

(. 313).

(. 51, 52).

Trypanosoma

(. 51).

Trypanosoma

mega

(. 314).

(

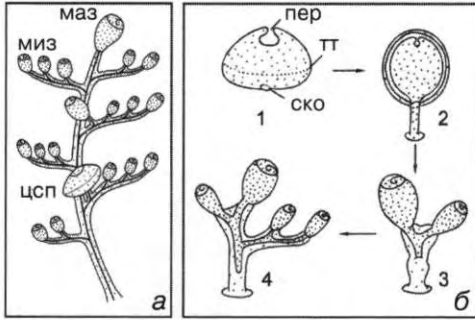

(. 316).

Dictyostelium discoideum (. . 180)

. 315.

Zoothamnium: —

Z. alternans

()

(),

(); —

Z. arbuscula: 1 —

(),

() (); 2 —

; 3 —

; 4 —

(—

, —).

().

315).

()

().

deum

Dictyostelium discoi

1

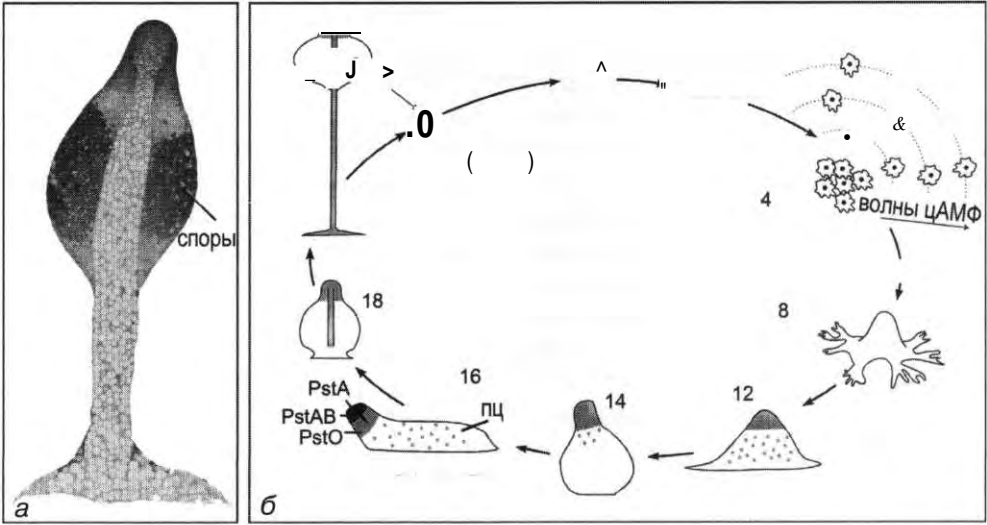

316. *Dictyostelium discoideum* ():

() *Dictyostelium*

PstA, PstAB, PstO —

(— 60)

(pstA pstB).

(pstAB)

Myxogastrea,

2.

179).

DIF (differentiation inducing factor — DIF I

lina; . . . 313)

Eufollicu

Apicomplexa).

Discoideum murocoides

) (. . . 80), 146).

, *Toxoplasma*;

Dimorpha mutatis

() ,

()

() .

(. 317) .

Amelia vulgaris

()

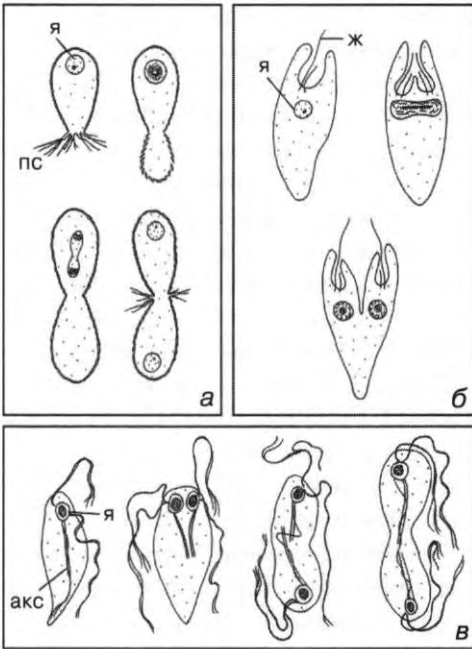

. 317 .

(*Euglypha*,) ,

(*Euglena*,)

{*Devescovina*,

), — () .

Euglena,

3176).

318).

Neph

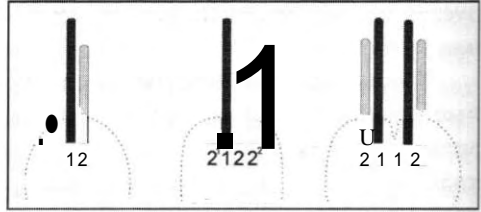

318.

Nephroselmis olivacea:

(1)

(2)

(2'

2²).

() .

roselmis olivacea

Hypermastigida

Joenia;

44).

(. 317) .

Volvox

Volvox carteri

(

)

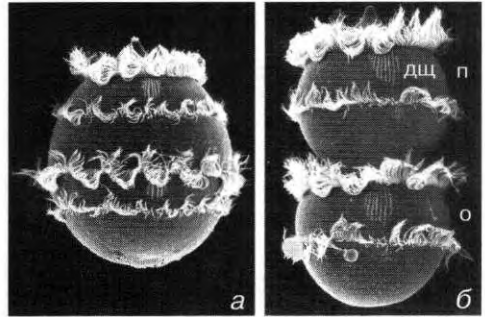

. 319.

Didinium nasutum:

Volvox carteri

Ephelota gemmipara

, *Tachyblaston ephelotensis*,

(. 3206).

Suctorio.

Acineta tuberosa

114).

2+

319).

(, *Halteria*, *Tintinnidium*).

Opercularia *Tintinnopsis subacuta*

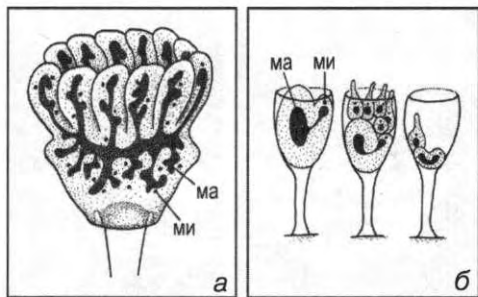

. 320.
lota () *Tachyblaston* (), —
 , — () .

. 129).

. 89)
 complexa

(, *Eimeria*,
 Api-

Eimeria

. 3036.);
)

(. . 90);

(, *Sarco*
cystis)

Pelomyxa,

()
 (. . 162).

Astomatia *Apostomatia* (. . 314)

(, *Radioph*
rya)

(. . 146);

(, *Haptophrya*).
Foettingeria

321).

(cyclin dependent protein kinases, Cdk).
Cdk

G₂ S
(. 321).

Cdk, G_k
(M phase promoting factor, MPF),

MPF,
Cdk G_r УНК

Cdk,

Cdk

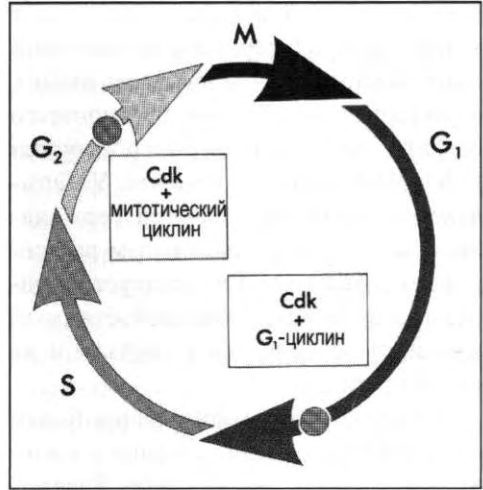

. 321.
(
)
(S) (). (Cdk)

. G, G₂ —

Tetrahymena

Tetrahymena pyriformis, *thermophila*
Paramecium caudatum

(meiosis reinitiating factor, MRIF),
MPF.

Tetrahymena *Paramecium.* *Tetra-*
hymena MRIF₂₊ -

()

Cdk,

(*Tetrahymena thermophyla*, *Parame-*
cium tetraurelia),

Dunaliella tertiolecta, *Dictyostelium*
discoideum *Plasmodium falciparum.*
Cdk,

(. . . 102).

Paramecium.

(. . . 105),

), , ,

(*Leishmania mexicana*, *Trypanosoma*
brucei),

(*Paramecium tetra-*
relia, *Stylonychia lemnae*, *Tetrahymena*
thermophila), (*Pro*
rocentrum minimum, *Alexandrium tama*
rense), *Dunaliella tertiolecta*, *Physarum*
polycephalum *Dictyostelium discoi-*
deum. *Eufolliculina uhligi*

Stentor, *Paramecium*, *Tetrahymena*

()

Cdk,

Cryptothecodinium cohnii

, (, -
).
 , ,
 -
 -
 , ,
 -
 -
 ,
 -
 , Stentor (-
 -)
) , Paramecium -
 -
 , Stentor Tetrahymena (. 322).
 (, -
 , Paramecium —) Paramecium -
 -
 , , -
 -
 -
 -
 -
 -
 Stentor, , -
 -
 (,
 -
 , -
).
 — , -
 -
 -
 : , -
 - ,

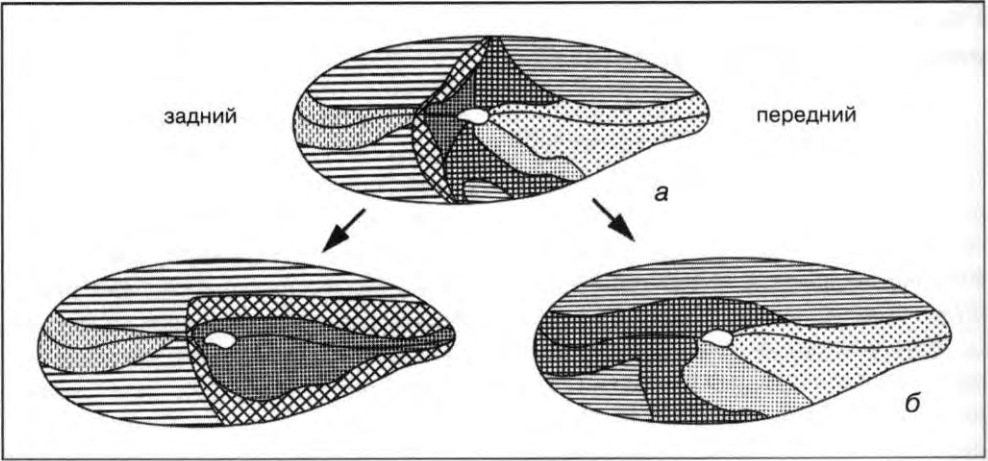

. 322.

Paramecium () ;

() :

Oxytricha.

Stentor

Paraurostyla weis

sei

« »

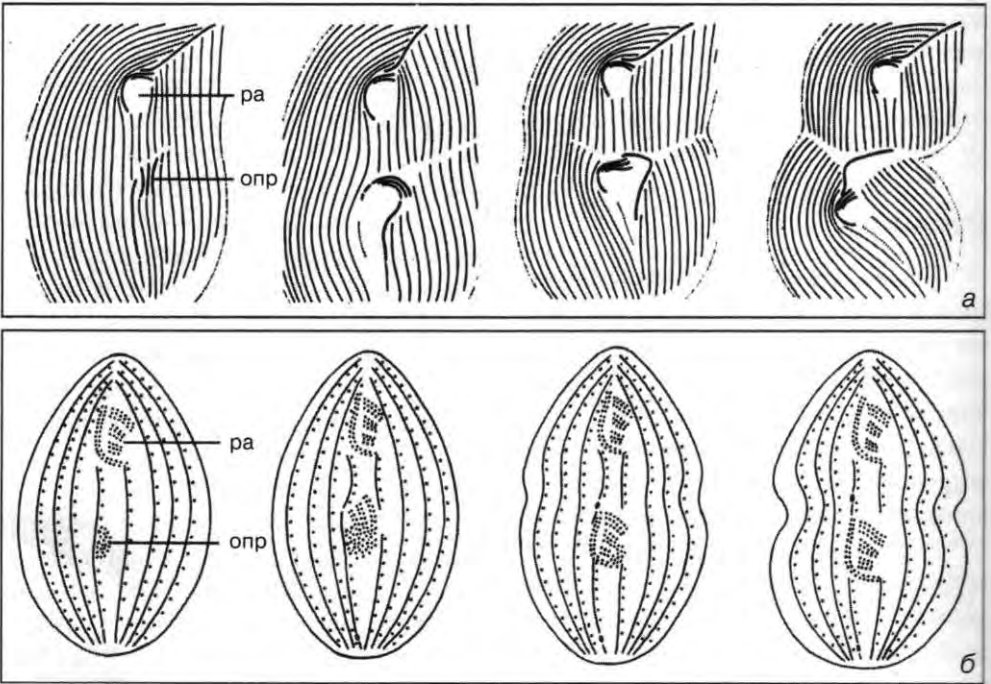

. 323.

Trithigmostoma steini; —

Tetrahymena. —

(— : Hofmann and Bardele: Europ. J. Protistol. 23 [1987] 2).

(. 324).

Oxytricha

fallax

de 324, 325).

novo.

Tetrahymena Paraurosyella

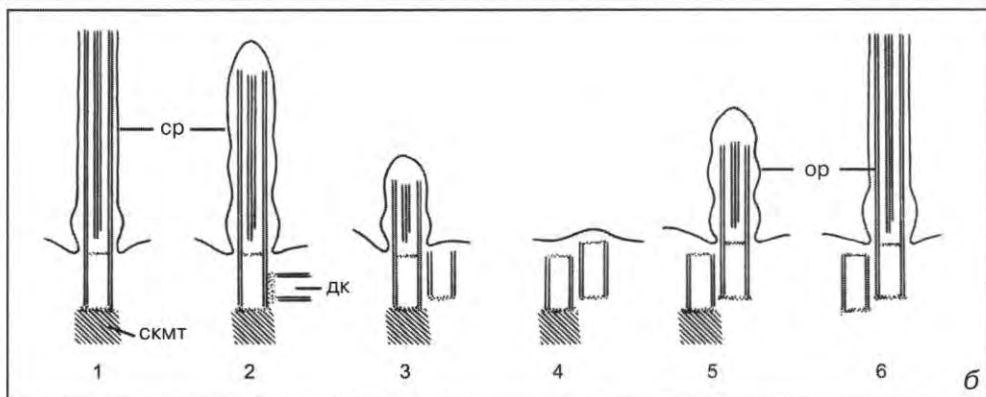
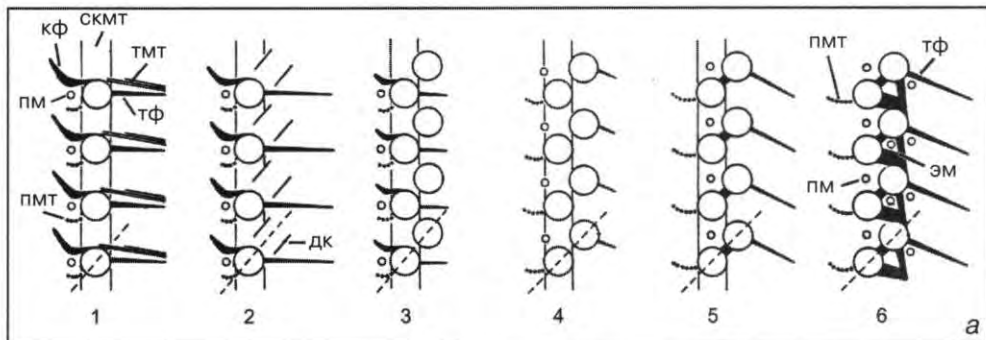

. 324.

Trithymostoma steini (—

; 2 4 — () ; 5 — () ; 6 —

Protistol. 23 [1987] 2).

(: Hofmann and Bardele: Europ. J.

(. 325).

Stentor

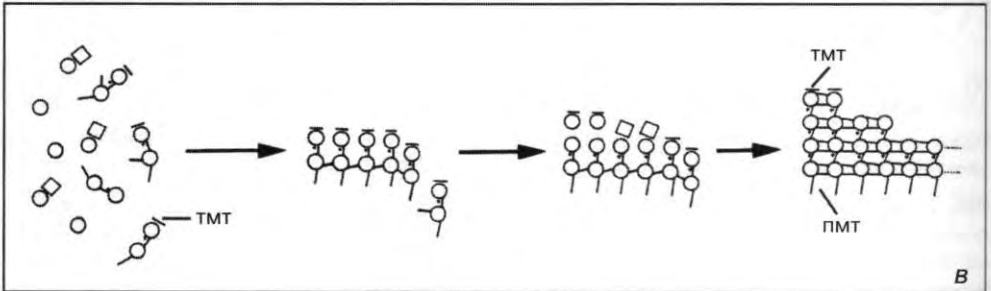
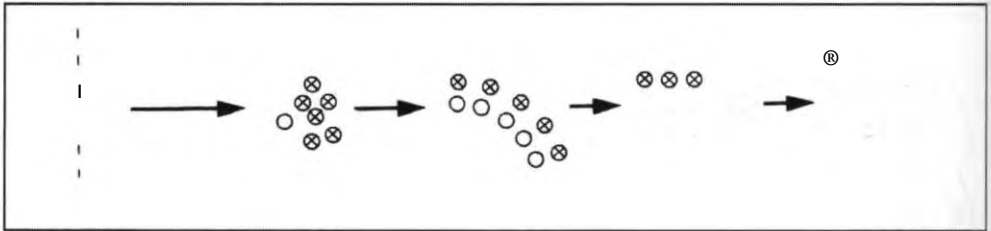
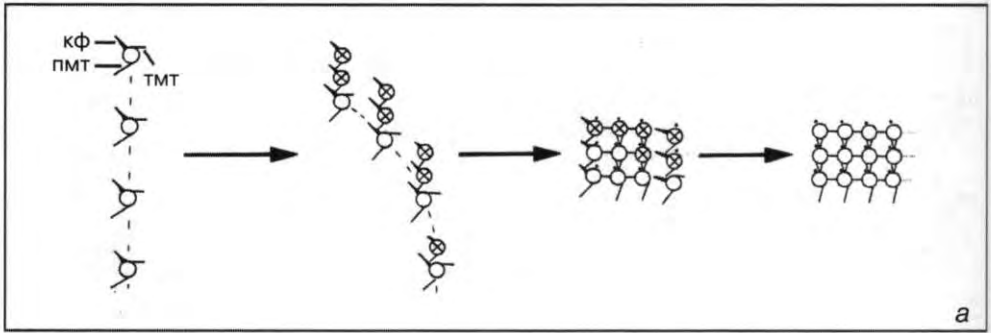

325. : — *Furgasonia blochmanni*; — *Tetra-*
hymena thermophila; — *Paraurostyla weissei*.

(: Eisler: *Europ. J. Protistol.* 24 [1989] 181).

(. 326).

(),

(. 326).

Stentor

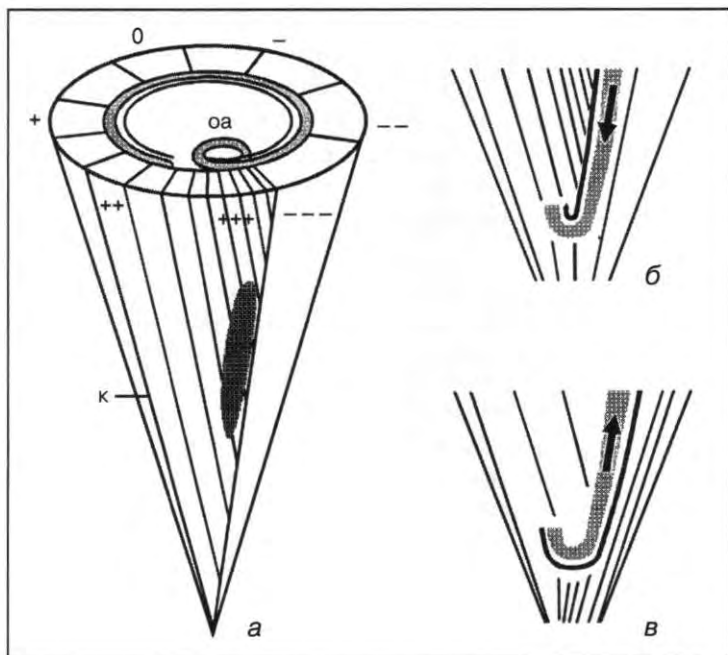

. 326.

) *Stentor*.

—

()

(—

).

(—/+++).

, —

—

()

()

()

;

—

).

(

)

).

(

Tetrahymena,

Paramecium.

()

10

vitro.

in

soma brucei

Trypano-

(. . . 51).
 « . . . » (variant surface glycoproteins — VSG).

14
 VSG.
 « » VSG
 1000
 VSG
 327).
 . *brucei*

VSG
 10^{-2} 10^{-6}

VSG

VSG,

327. . . *brucei*
 20 100

1000

VSG.

1
 VSG

VSG

(ELC VSG

VSG:
 3

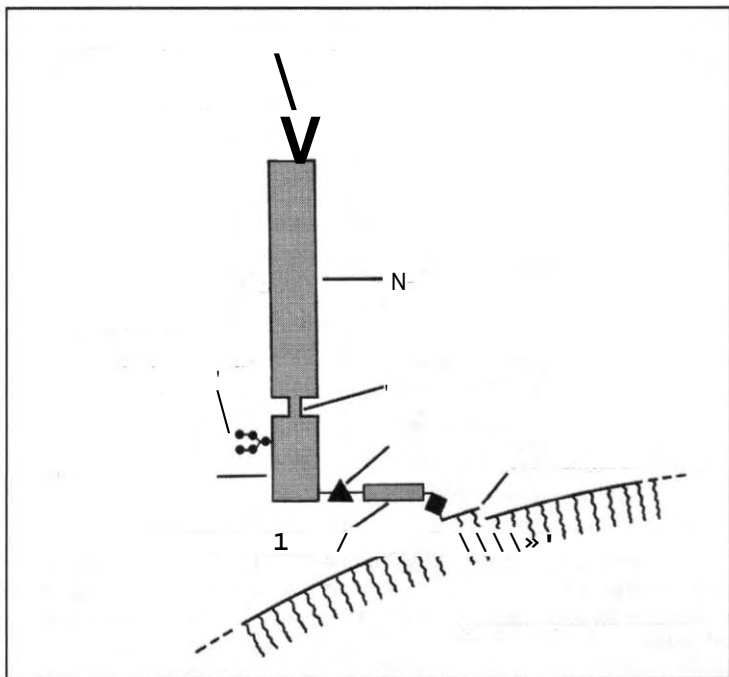

. 329.
VSG *Trypano-*
soma congolense (по
).

() .

()

50%

(guide RNA,

(. 330).

Physarum

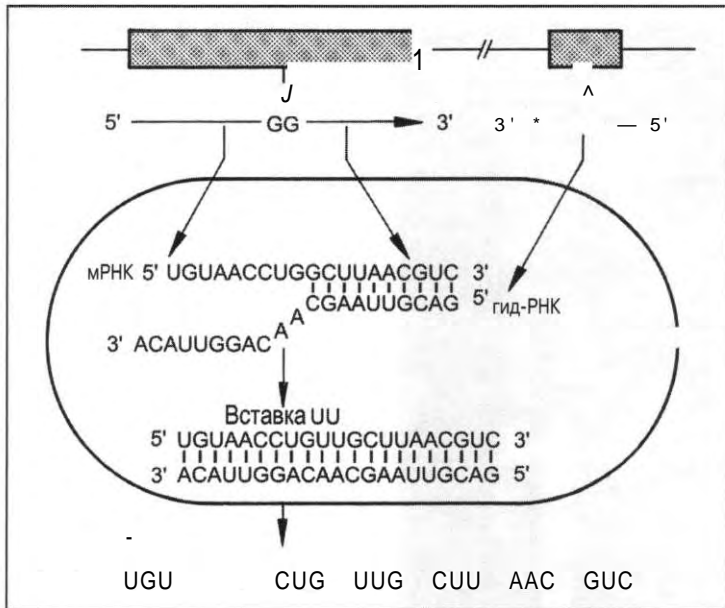

. 330.

() .

(

),

?

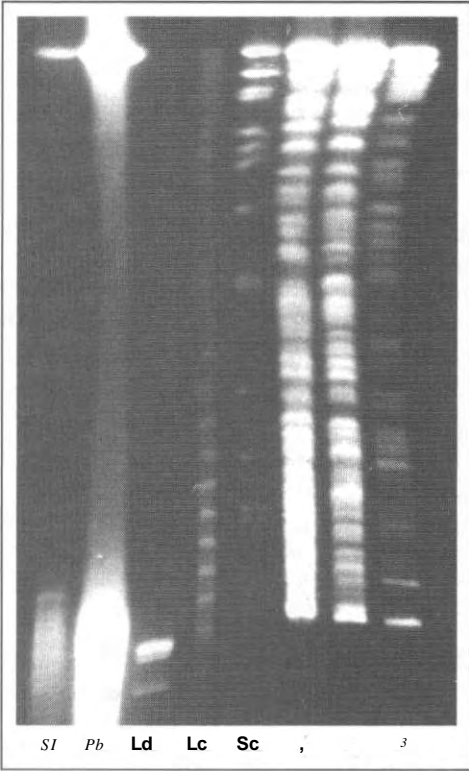

Hymenostomata (

Tetrahymena

Paramecium)

Stichotrichia Hypotrichia (

, *Stylonychia*, *Oxytricha* *Euplotes*).

(
).

. 331.

Tetrahymena

hymena 10 20%

thermophila (₂)

pyriformis (₃)

Stylonychia lemnae (SI) *Paramecium*

bursaria (Pb),

{*Saccharomyces cerevisiae*, Sc),

(Lc)

(Ld).

331).

49

Tetrahymena

20 1000

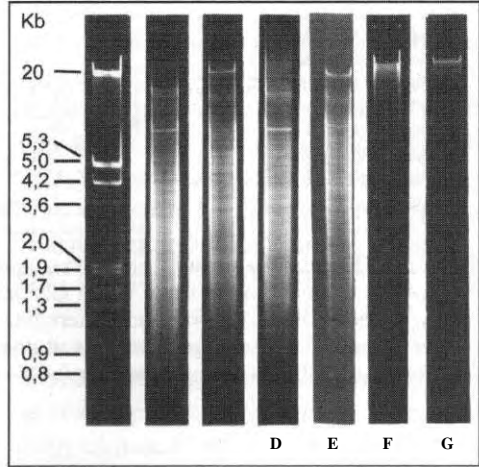

(. . . 302).

Stylonychia

98%

100 15
hymena

(. . . 332). *Tetra-*

. 332.

mecium

F —

G —

Para-

0,5

10

333.

50 -

(internal eliminated segments, internal eliminated sequences — IES),

(macronuclear destined sequences — MDS), —

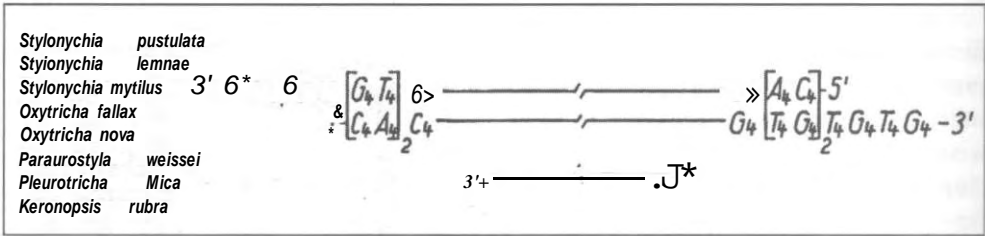

. 333.

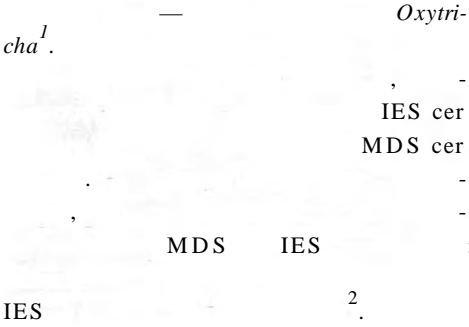

Hymenostomatia, Stichotrichia

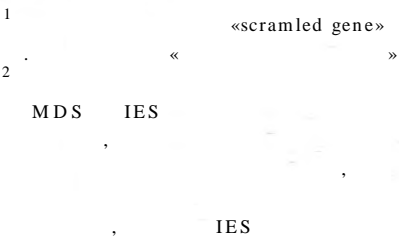

Tetrahymena

Tetra-

hymena

(. 17).

Tetrahymena Euplotes.

Tetrahymena

TTGGGG

Tetrahymena.

Euplotes

TTTTGGGG

Euplotes.

Tetrahymena

3'

17.

Didymium

Ciliophora	<i>Tetrahymena</i>	TTGGGG
	<i>Glaucoma</i>	TTGGGG
	<i>Paramecium</i>	TT(T/G)GGG
	<i>Stylonychia</i>	TTTTGGGG
	<i>Oxytricha</i>	TTTTGGGG
	<i>Paraurostyla</i>	TTTTGGGG
	<i>Onychodromus</i>	TTTTGGGG
	<i>Urostyla</i>	TTTTGGGG
	<i>Keronopsis</i>	TTTTGGGG
	<i>Pleurotricha</i>	TTTTGGGG
	<i>Euplotes</i>	TTTTGGGG
Kinetoplastidea	<i>Trypanosoma</i>	TTGGGA
	<i>Crithidia</i>	TTGGGA
Apicomplexa	<i>Plasmodium</i>	(C/T)TTGGGA
Myxogastrea	<i>Physarum</i>	TTGGGA
	<i>Didymium</i>	TTGGGA
Dictyostelia	<i>Dictyostelium</i>	AG,,,
Chlorophyta	<i>Chlamydomonas</i>	TTTTGGGA

vitro

G

() ,

in

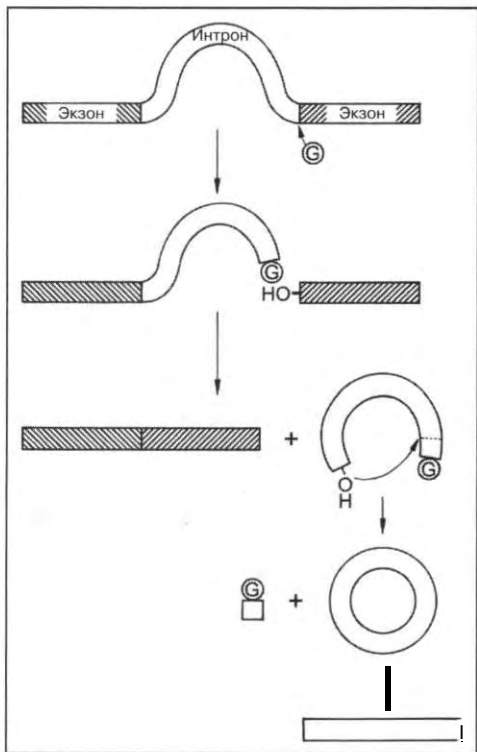

334.
thermophila.

Tetrahymena

(G)

2.

G

(

(334).

Tetrahymena, Paramecium, Stylo-
nichia Oxytricha —
 TAG, —

Physarum

18. TAG TGA,

	TGA	TAG
<i>Tetrahymena</i>		Gin Gin
<i>Paramecium</i>		Gin Gin
<i>Stylonychia</i>		Gin Gin
<i>Oxytricha</i>		Gin Gin
<i>Paraurostyla</i>		Gin Gin
<i>Euplotes</i>	Cys	
<i>Blepharisma</i>	?	?

(. 18).

, — TGA. *Tetrahymena ther*
mophila

TGA.

Apicomplexa:

Plasmodium falciparum, *P. vivax*, *P. ovale*
P. malariae.

Plasmodium,

. *Euplotes* *Blepharisma*

TGA (

)

Euplotes.

Euplotes

Hypotrichia

Stylonychia

Oxytricha,

TGA

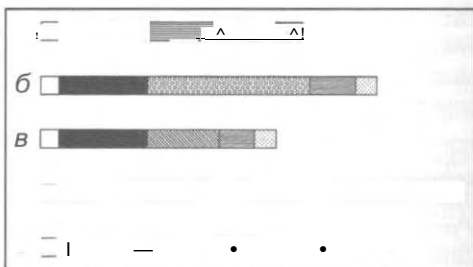

. 335.

Plasmodium falciparum.

() .

P. falciparum

96).

(. . 97, 98).

dium

Plasmo-

20

(S 1).

VSG

(. . 335).

S

P. falciparum

■

Chlamydomonas.

tyostelium *Entamoeba*

Dic

1

()

()

(. 336).

nychia Euplotes)

2+

(Stylo

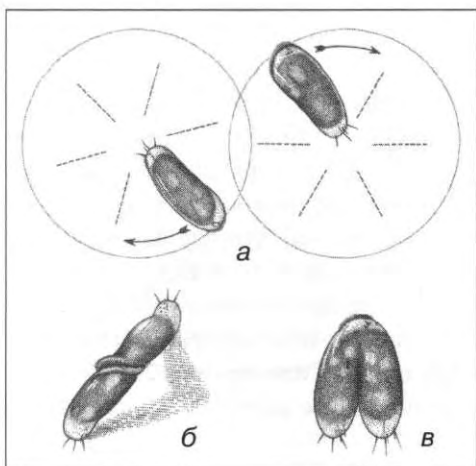

. 336. «
Stylonichia mytilus:

()

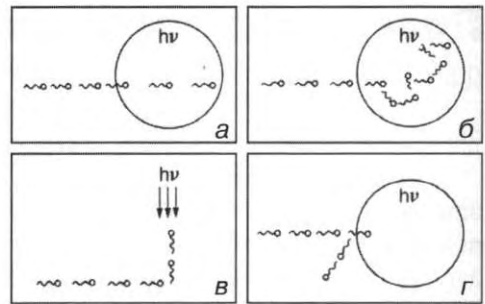

. 337.

(...)

($h\nu$): — ()

(...)

); — :

),

()

(. 337).

(...).

(. 337 , ,).

, , -
 , , -
 (. 337). -
 (. 3376). —
 - ,
 - ;
 - — (.).
 (- -
 ; . 337 ,) , -
 (; . 337). -
 — (,
 — ; .). ,
 , ,
 - -
 — -
 , -
 - -
 , -
 - -
 , -
 , -
 , -
 , -
 , -
 — -
 , -
 - ()
 (. 337). , -
 — -

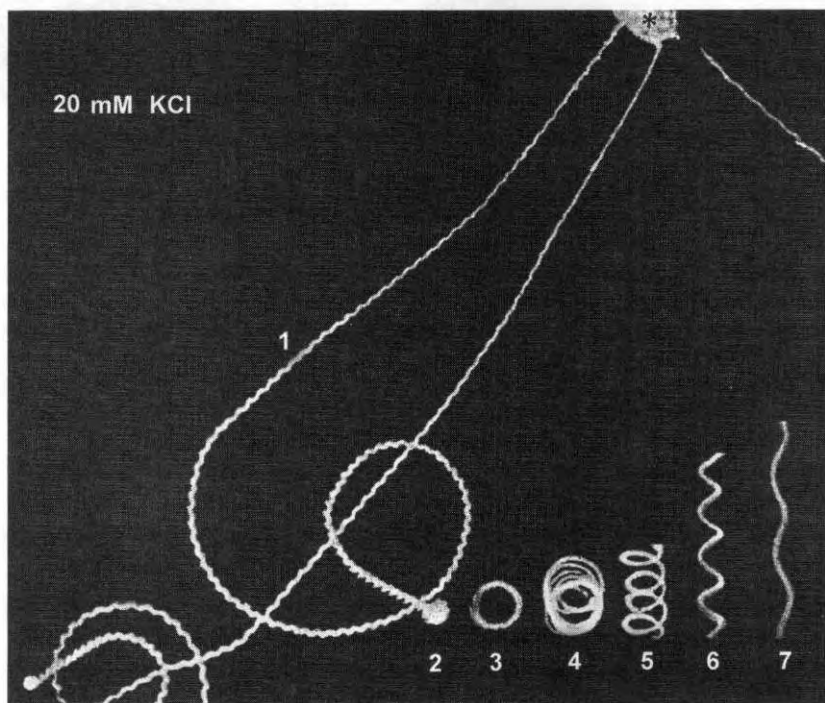

338. *Paramecium*

20 mM KCl

(*)

(1).

40

(2).

(3)

(4-7).

7-

463).

339,

(: Machefer: J. Protozool. 36 [1989]

Paramecium.

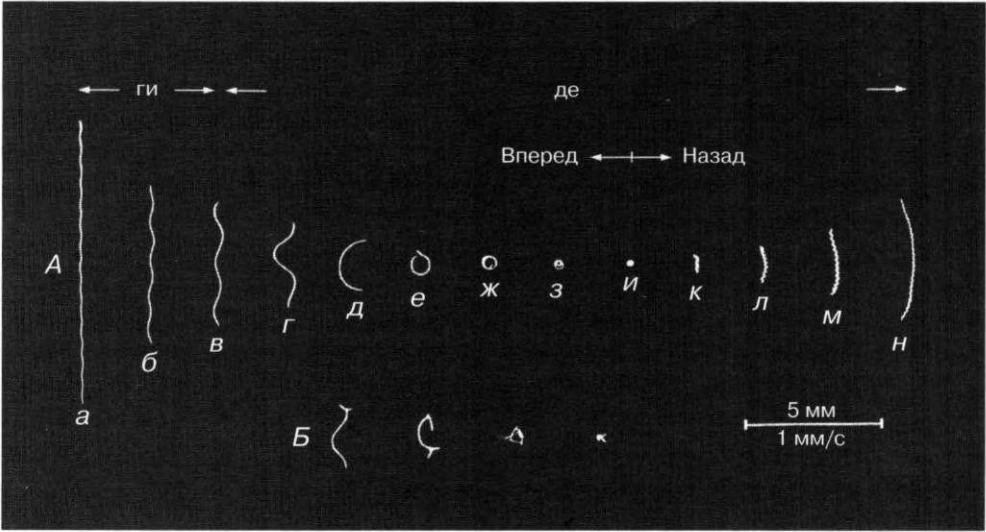

339. *Paramecium*
 ()
 ()
 () ; () ; ()
 ()
 (: Macheimer and Sugino: . Biochem. Physiol. 94A

[1989] 365).

338).

(. 339)

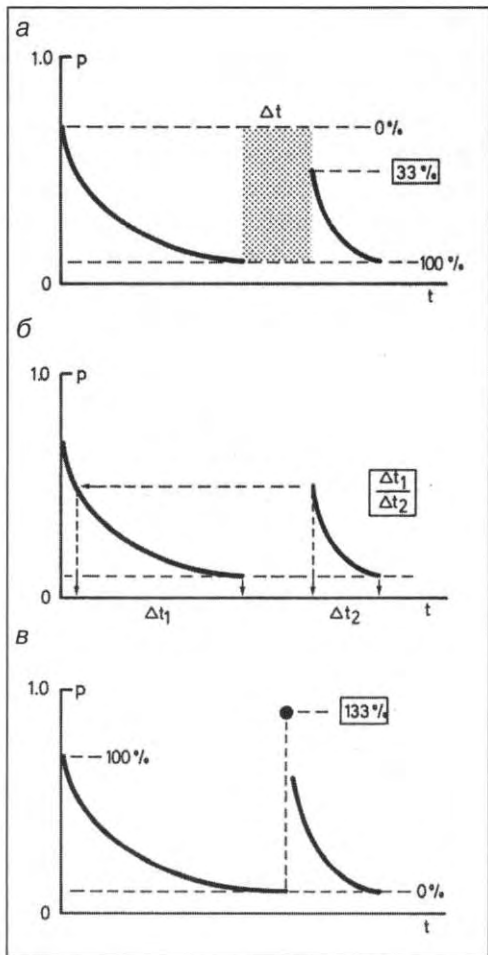

340.

Spirostomum

()
 ;
 (t)
 12 , —
 ;
 100% ;
 (At),
 (33%) , —
 ;
 100% ;
 () —
 () ;
 (: Macheimer:
 BIUZ 18 [1988] 122).

chia

Stylony-

340).

Spirostomum Stentor,

. 339),

Paramecium,

()

(),

(),

(. 3416,1).

(. 341).

2

II-I, III-I).

(. 3416,

(. 3416).

();

(*Opalina,*

Chilomonas).

(

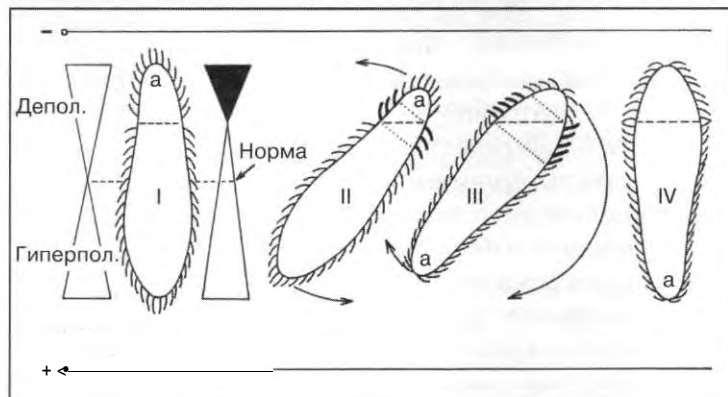
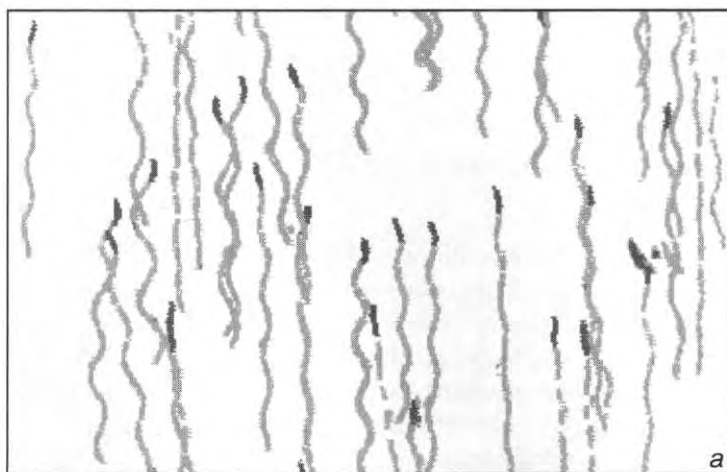

. 341.

Paramecium, —

() , —

) () , —

() () .

(. — , — ; —

) . , . II,

III: , () , () ,

, . IV:

(+),

III

I (: Macheimer: Galvanotaxis: Grundlagen der elektro-
mechanischen Kopplung und Orientierung bei *Paramecium*. In: Praktische Verhaltensbiologie,
ed. by G.H.K. Zupanc, Parey, Berlin 1988).

(*Spirostomum, Cli
macostomum*)

(*Spirostomum, Cli*

(*Loxodes*).

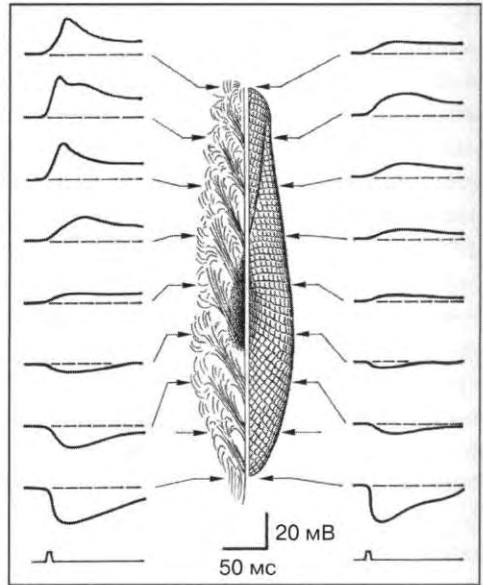

Stentor

Paramecium

. 342.

Paramecium (

(. . . 255).

(*Paramecium, Stylonychia*)

342).

Paramecium

(: Ogura and Machemer: J.
. Physiol. 135 [1980] 233).

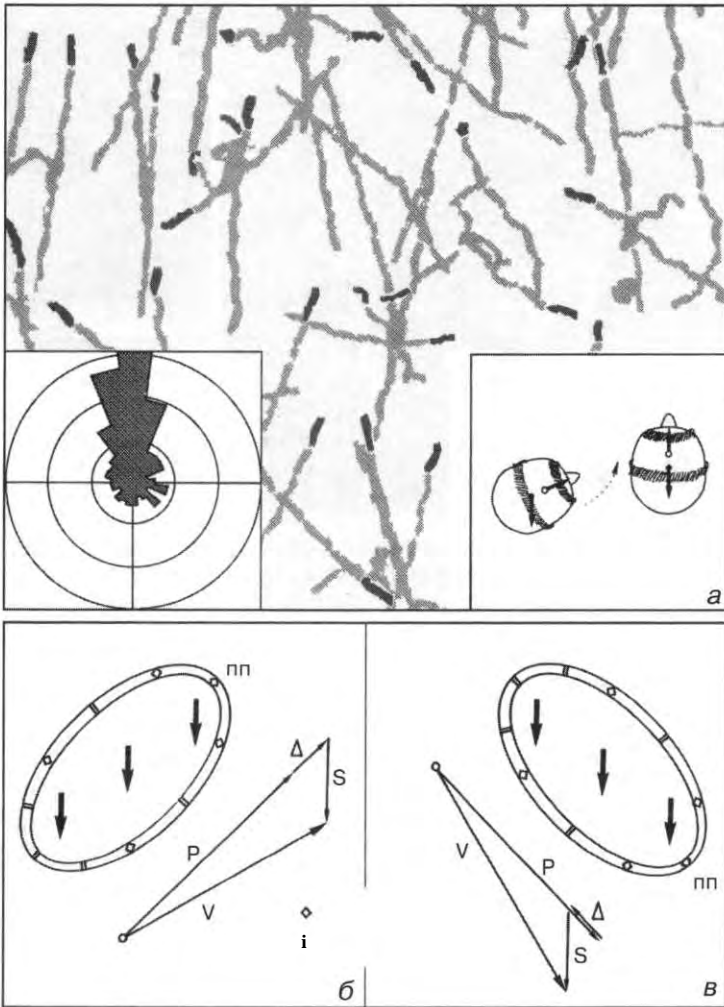

. 344.

Didinium.

(), (), , -
 (), (-) .
 ; 2+ ;
 342). -
 (- propulsion) (V) -
 (S)
 V, S. () . ()

(: Machefer and Braucker: Acta Protozool. 31 [1992] 185).

(. 342)

(. .

Loxodes

339).

,

.

,

(g),).

(

+

. .)

(-

. —

2

). —

(.

« »

Loxodes

; . . 116, 117).

(

)

Paramecium

(. 3446),

1

Loxodes

2

Paramecium

Paramecium

2+

^

(« »),

Paramecium

(

)

12

. *Didinium*,

: (1)

; (2)

0²

».

; (3)

Paramecium.

Paramecium

1

(. . . 307),

+

(*Paramecium*),

(*Blepharisma*,

Plasmo-

Euplotes).

Chlamydomonas

dium

()

($\geq 10^3$)

Paramecium

Amoeba proteus

(
) 10

Paramecium bur

saria,

(

)

(

).

(
, —).

(
—).

mydomonas (. 345).

mecium bursaria
cium multimicronucleatum

Para-
Parame-

2+

2+

10"

).

Paramecium

2+

(10^8).

Paramecium (. рнс:

255),

Paramecium bur-

saria

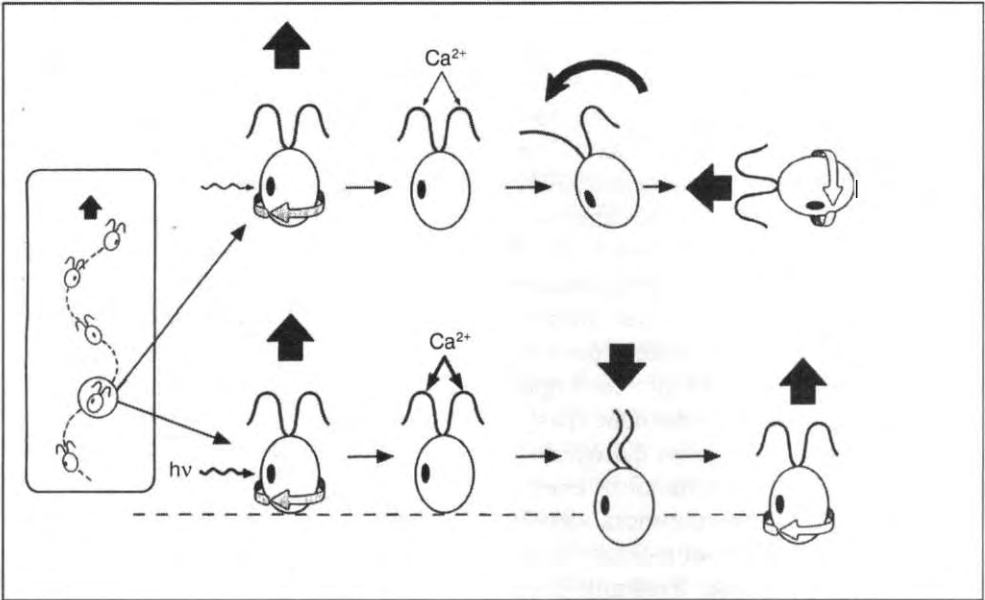

345.

Chlamydomonas.
().

().

2^+

().

2^+

().

().

()

2^+

().

().

2^+

() (: Witman: TICB 4 [1993] 403).

1

1

().

(

).

Chlamydomonas

Ophryoglena,

(. 345).

2+

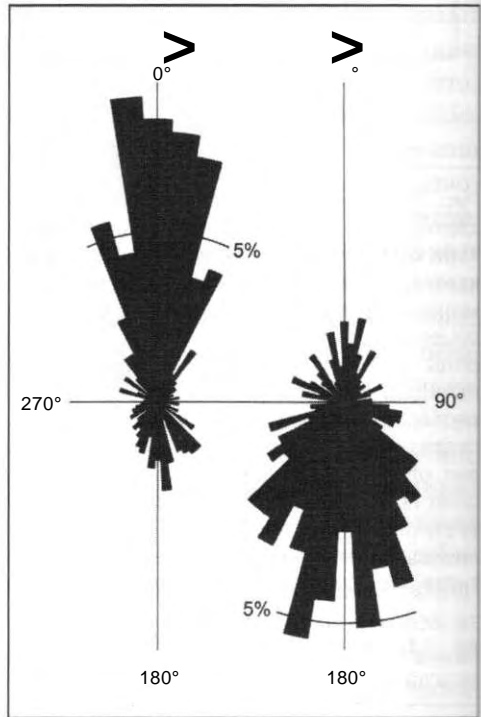

. 346.

Ophryoglena

()
Ophryoglena (: Kuhlmann: Europ. J. Protistol. 29 [1993] 344).

Chlamydomon —

— *Ophryoglena*.

— *Stentor*, *Fabrea*

(. 346).

(. 347).

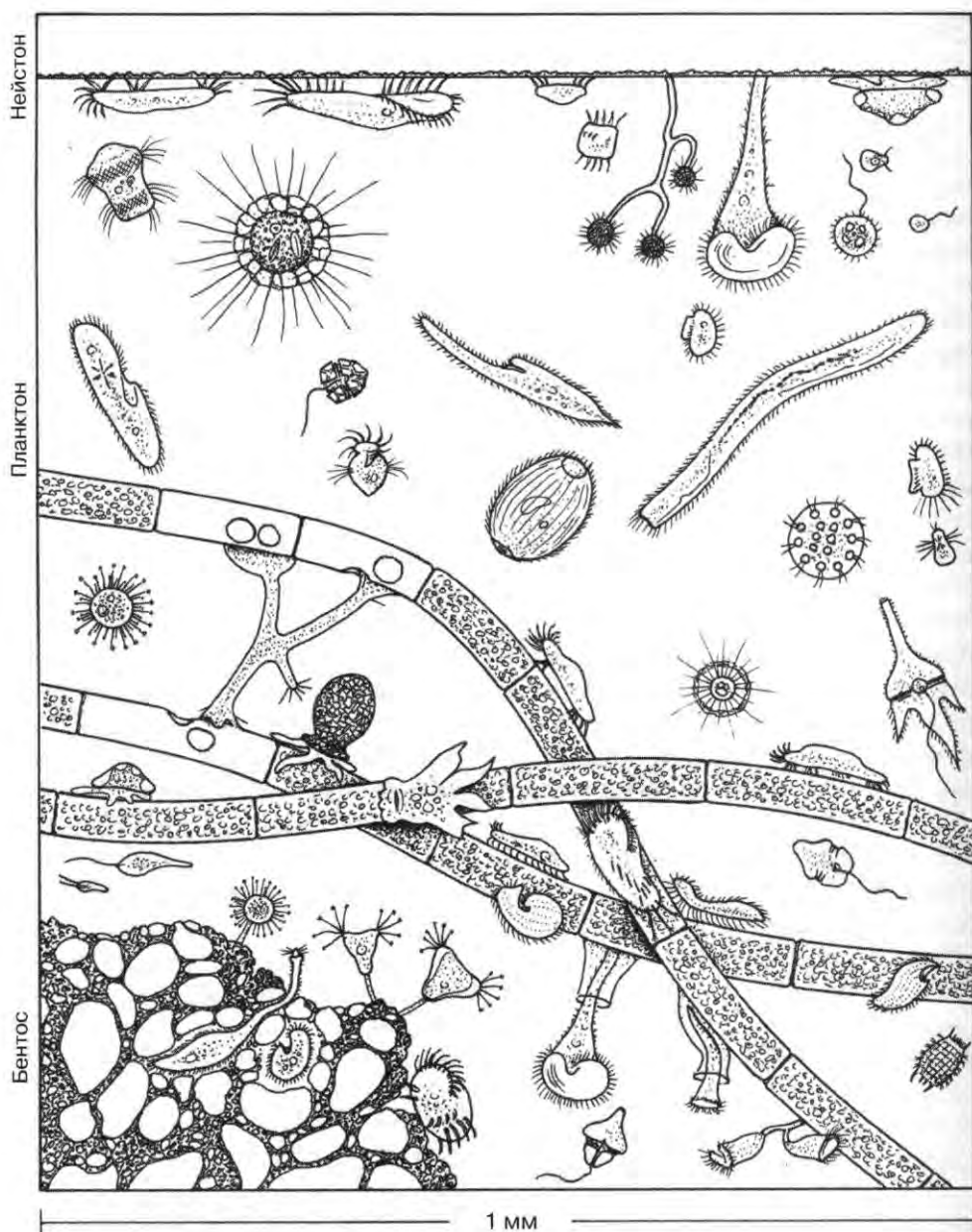

Colpoda

Colpo-

da

(. 348).

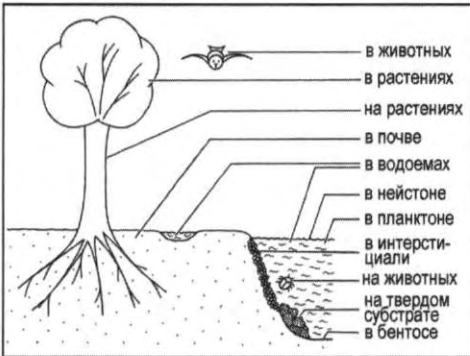

Paramecium multimicronucleatum

()

348.

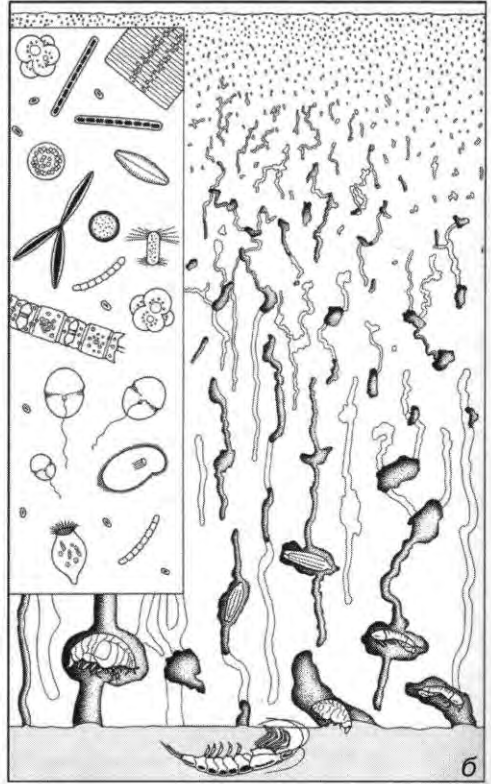
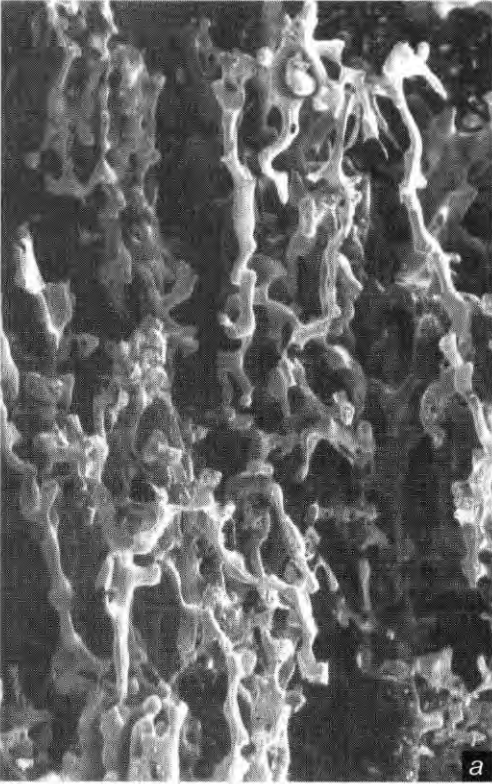

349. (a) —
);
 —
 ;
 Limnol. Oceanogr. 37 [1992] 179; —

(b) —
 (— : Weissenberger et al.:
). : 15 .

Thecamoeba terricola.

Colpoda,

20,

(. . . 56, 179, 180)

Sorogena (. . . 226)

100

(. . . 349).

NaCl¹

144% (10 °);

38% ².

¹ NaCl,

² 35% ,

38%

Amphidinium, *Gymnodinium* — *Glenodinium*,

Oxytricha fallax

41 56 ° ,

Euplo-

tes

2 ° (. 350).

35 °

Dunaliella (Chlorophyceae),

Trimyema minutus

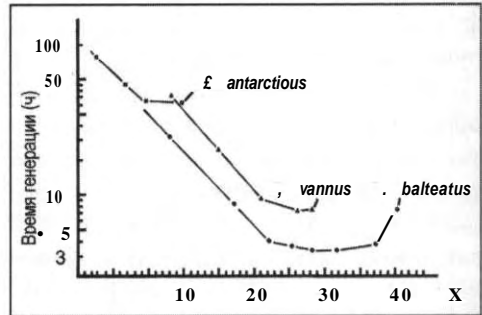

. 350.

Euploetes: . *antarcticus* (. . .) ,

. *vannus* (. . .) , £. *balteatus* (. . .) .

40 ° .

(. . .) .

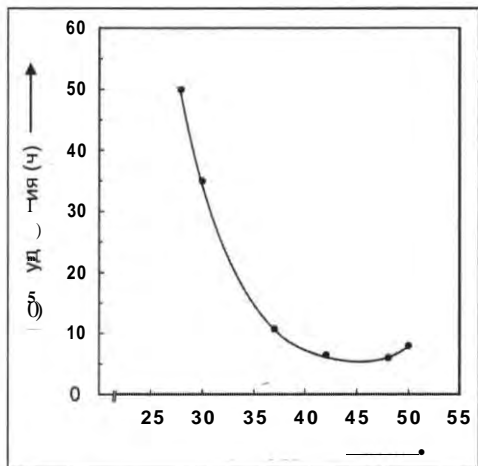

50 ° ;
 — 6 —
 48 ° (. 351).
 (Schizopy
 renida, Heterolobosea)
 40 °
 (*Naegleria fowlery*, *N. australiensis*)
 (. 19).

. 351.
 EV10
Trimyema minutum.

28 ' 52 " (: Baumgartner et al.:
 J. Eukaryot. Microbiol. 49 [2002] 227).

Noctiluca scintillans (. 352),

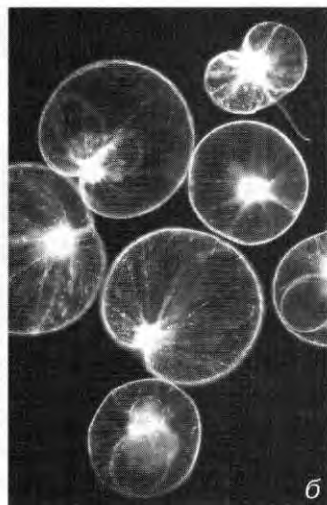
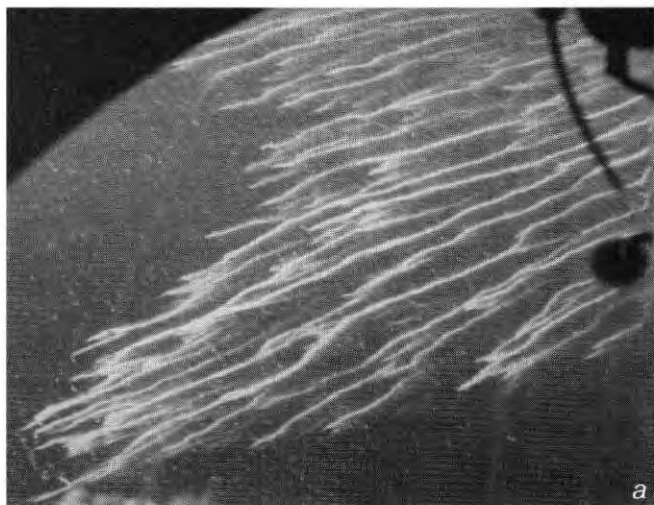

. 352. *Noctiluca scintillans* (); —
Noctiluca (—) . . — 25 .

19. *Naegleria* -

4 ° (: de

Jonckheere: Acta Protozool. 41 [2002] 309)

<i>Naegleria</i>	(°C)
<i>N. andersoni</i>	40
<i>N. australiensis</i>	42
<i>N. carteri</i>	45
<i>N. chilensis</i>	30
<i>N. clarki</i>	37
<i>N. fowleri</i>	45
<i>N. fultoni</i>	35
<i>N. galeacystis</i>	35
<i>N. gruberi</i>	39
<i>N. indonesiensis</i>	38
<i>N. italica</i>	42
<i>N. jadini</i>	35
<i>N. jamiesoni</i>	42
<i>N. lovaniensis</i>	45
<i>N. minor</i>	38
<i>N. morganensis</i>	44
<i>N. niuginensis</i>	45
<i>N. pagei</i>	37
<i>N. pringsheimi</i>	37
<i>N. pussardi</i>	41
<i>N. robinsoni</i>	38
<i>N. sturti</i>	44
<i>N. tihangensis</i>	42



. 353.

(),

Phaeo

cystis

1981

(

X.

).

Chrysochromulina polylepis,

« »

1988

Phaeocystis.

(. 353).

Metopus

nomorpha

Trepomonas

mita.

2,

(. 354).

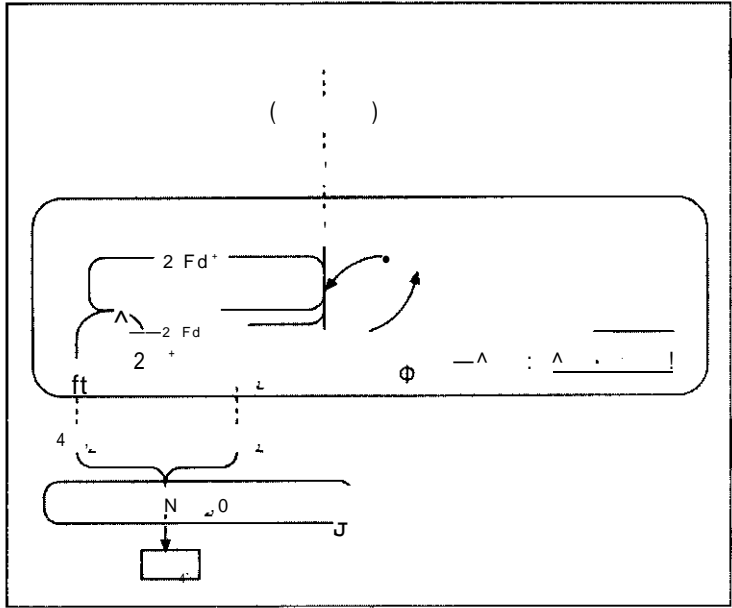

. 354.

() .

(, *Loxodes Spirostomum,* -

.)

Chlorella Trebouxia, -

(. 355).

Loxodes

Climacostomum virens Paramecium , , -

bursaria, -

Vorticella Frontonia. (. . 116, 117).

(. . 116, 117).

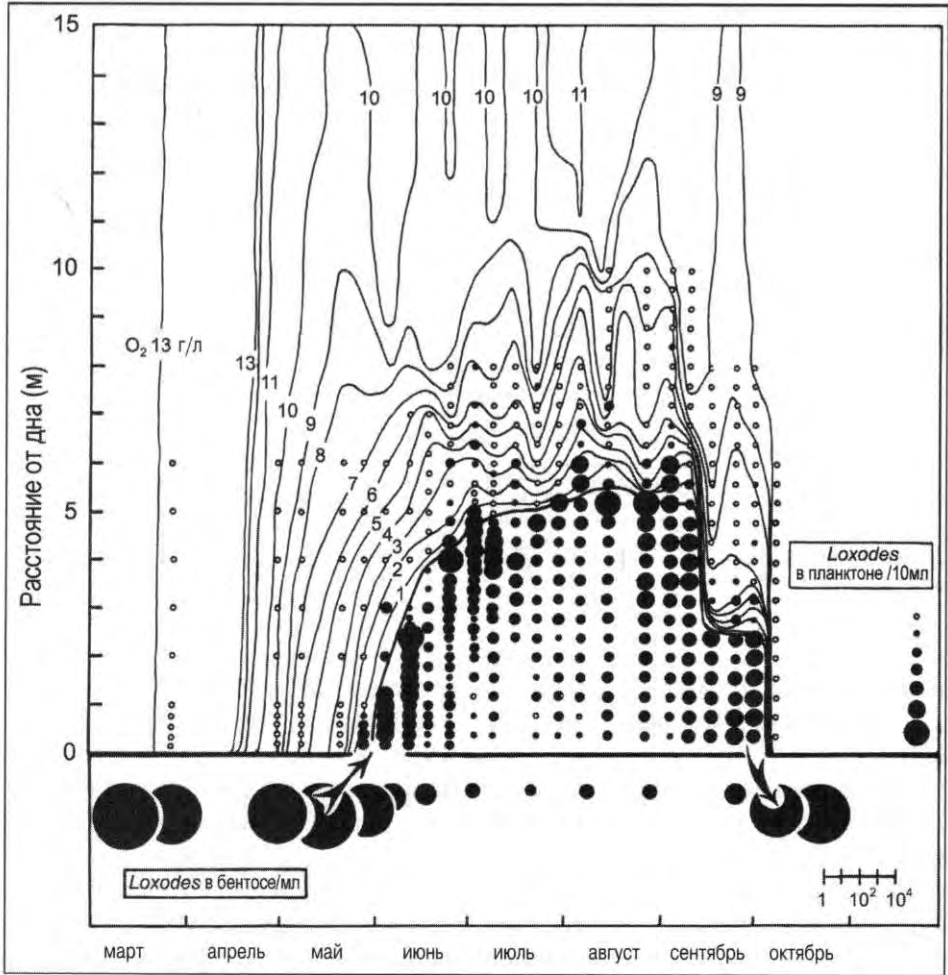

355.
 Water, Lake District, England
 (0 2 /)
 Loxodes

Loxodes (Esthwaite
 O₂)

5 6

Finlay and Fenchel: Freshwater Biological Association Annual Report 54 [1986] 73).

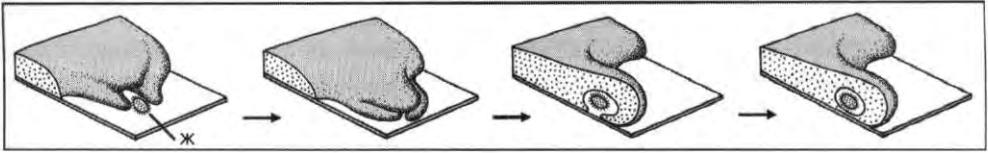

. 356. *Amoeba proteus*. — ().

(. 356). *Reti*
culomyxa (Foraminifera)

Volvox (. 357).

358).

Spirochona,

Vorti

cella Stentor

Ophrydium versatile.

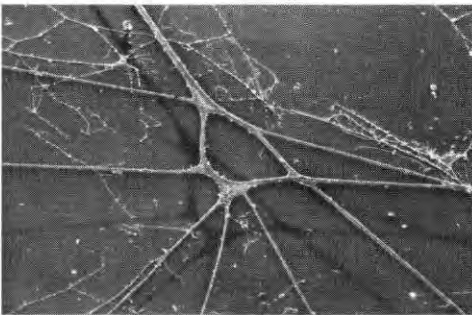

. 357.
culomyxa filosa,

: 200 .

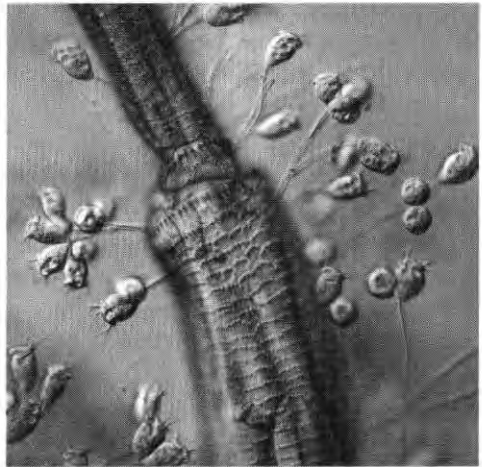

Reti

. 358.

(: Hausmann
and Rambow: Mikrokosmos 74 [1985] 208).
: 110x.

1963 :

Tokophrya lemnae

(*Lemna minor*).

15

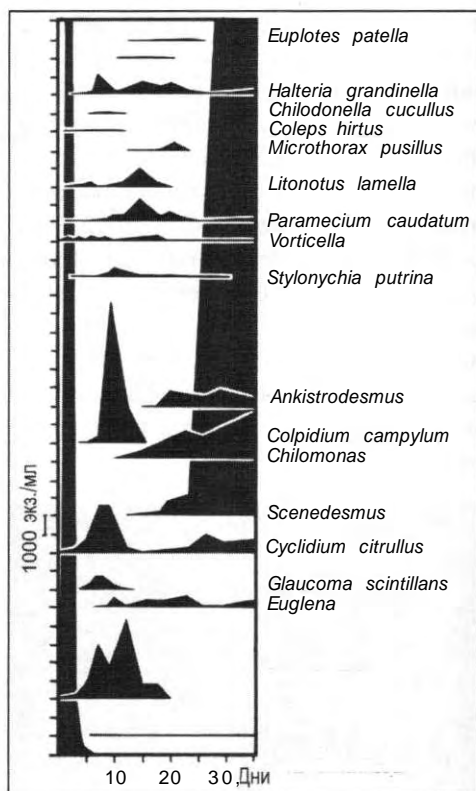

60

359.

35 ().

Didinium nasutum *Paramecium caudatum*,
Trachelius ovum *Ophrydium*
versatile.

(. 359).

(. 361).

(. 360).

Vorticella
Hemiophrys,

Hemiophrys

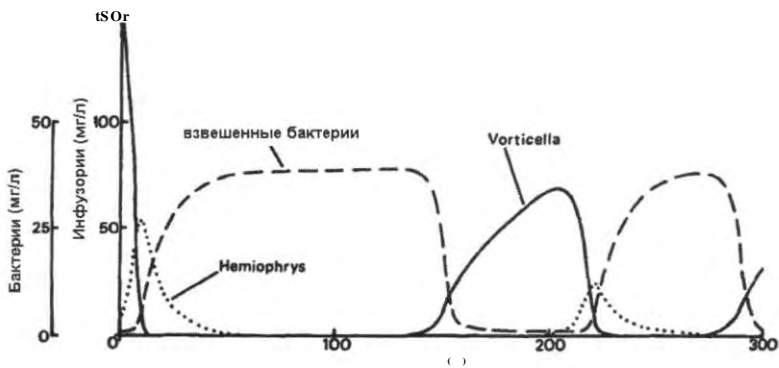

. 360.

Vorticella

Hemiophrys () .

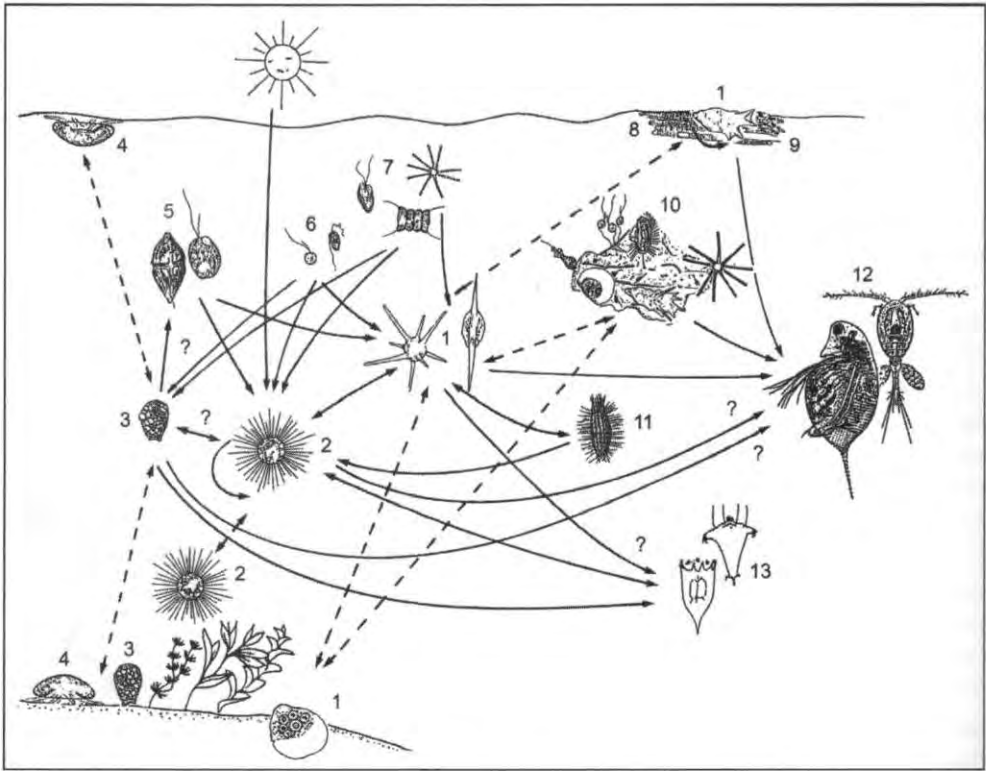

. 361 .

-
- . 1 —
- , 2 —
- , 3 —
- 4 —
- , 5 —
- , 6 —
- , 7 —
- , 8 —
- , 9 —
- , 10 —
- , 11 —
- , 12 —
- , 13 —

(: Arndt: Marine Microbial Food Webs 7 [1993] 3).

(. . 142),

(. . 55, 312)

(. . 26).

2 4%

(,)

—

(. . 310).

Chlorella

(. . 362),

40%

(

Vorticella

Hyalosphenia papilio,

Mayorella viridis,

cystis turfacea

costomum virens.

Acantho

Clima

Amoeba proteus *Chaos*

chaos

Pseudomicrothorax

dubius,

Vampyrella,

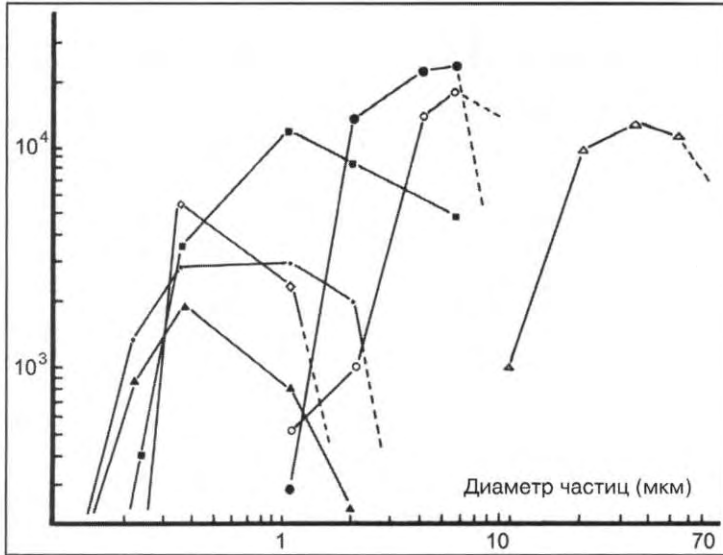

. 362.

Glaucoma scintillans, • — *Paramecium caudatum*, — *Blepharisma americanum*, • —
Colpidium campylum, 0 — *Cyclidium glaucoma*, • — *Euplotes moebiusi*, — *Bursaria*
truncatella ().

100%

: 500

(. . 347, 348)

20

(2 20) 50%

(20 200)

(

20.

1	0.2 2	
2	2 20	()
3	20 200	()
4	200 2 000	()
5	2 20	()
6	20 200	()
7	200 2 000	
8	2 20	

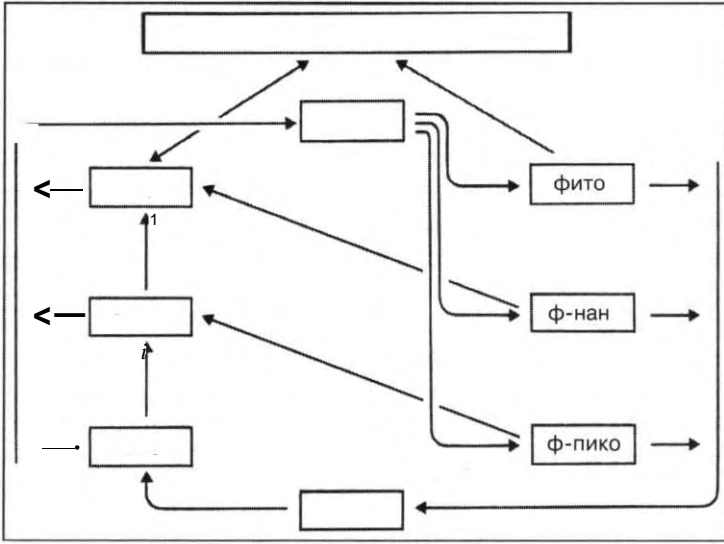

363.

2 (2 20), (0,2
 (20 200), ()
).

(3)

100 ;

180

350

(363).

364.

1 (365). (1)

, (2)

100 250

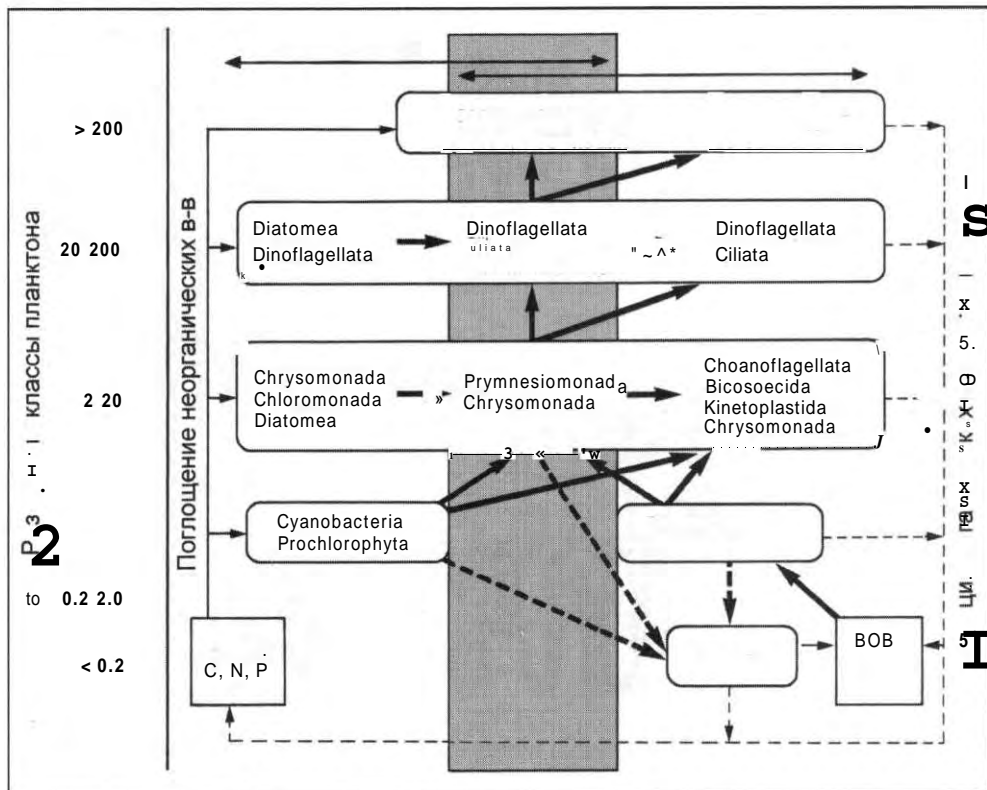

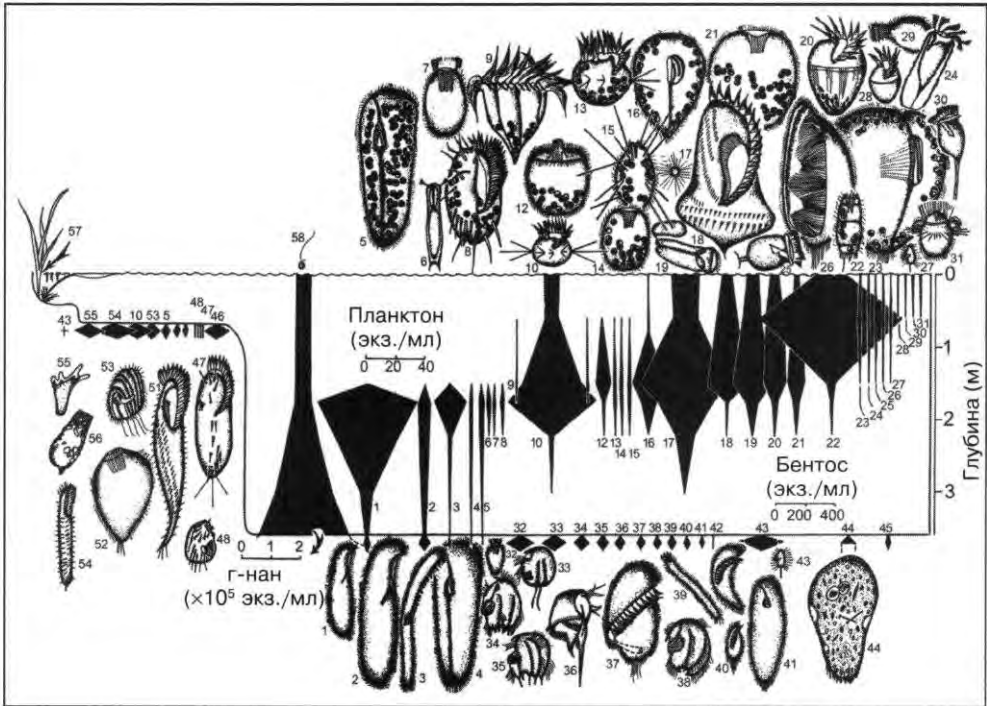

. 365.

(,).
 , [S] (sequestered) — , [Z]
 ; — (1 5 44), (: Finlay et al.: Europ. J. Protistol. 23 [1988] 205).
 1 — *Loxodes striatus* (200; ; 5 50); 2 — *Loxodes magnus* (400; ; 5 50);
 3 — *Spirostomum teres* (300; ; 2 10); 4 — *Frontonia leucas* (300; ; 3 50);
 5 — *Frontonia vernalis* (300; [Z]; 3 50); 6 — ; 7 — *Enchylis* sp. (60; ; <5);
 8 — *Euplotes daidaleos* (80; [Z], ; <5); 9 — *Strombidium velox* (50; [Z]; 5 10);
 10 — *Halteria grandinella* (50; [Z]; 5); 11 — ; 12 — *Monodinium balbiani* (75; [Z]; 5 10);
 13 — *Halteria grandinella* var. *chlohgella* (50; [Z]; 5); 14 — *Prorodon* sp. 1 (50; [Z]; 2 5);
 15 — *Actinobolina radians* (60; [Z]; 5); 16 — *Disematostoma* (75, 100; [Z]; 3 20);
 17 — *Acanthocystis pantopodeoides* (18; ?; <5); 18 — *Hypotrichidium conicum* *H. geleii* (120/100; ; 3 25/2 10);
 19 — ; 20 — *Strombidium viride* (70; ; 2 10); 21 — *Prorodon* sp. 2 (80 100; [Z]; 2 15);
 22 — *Coleps hirtus* (45; [Z]; 2 5); 23 — *Stokesia vernalis* (150; [Z]; 3 30);
 24 — *Tintinnidium* sp. (75; ; 2 5); 25 — *Vorticella bosminae* (20; ; <2);
 26 — *Lembadion magnum* (120; ; 5 25); 27 — *Cyclidium* sp. (20; ; <2);
 28 — *Strombidium* sp. (30; ; 2 5); 29 — *Enchelydium clepsiniiforme* (60; ; 2 5);
 30 — *Vorticella* sp. (40; ; <2); 31 — *Askenasia volvox* (40; ; 2 5);
 32 — *Enchelydium amphora* (35; ; <5); 33 — *Mylestoma anatinum* (25; ?; ?);
 34 — *Epaxella* sp. (30; ?; ?); 35 — *Saprodinium*

1

(. 366).

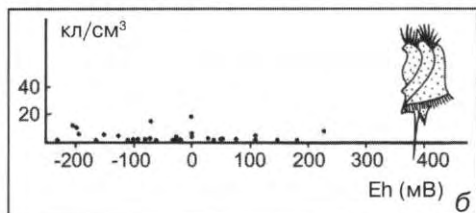
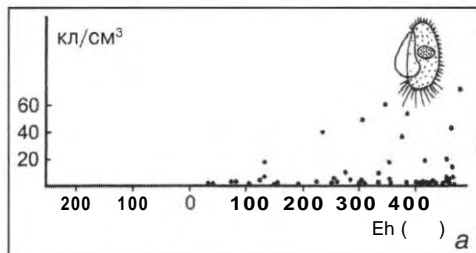

. 366.

Pleuronema coronatum ()

morpha levanderi ()

(Eh) ().

Remanella,

(. 367).

(. 368).

1

sp. (40; ; <2); 36 — *Caenomorpha lauterborni* (70; ; 5); 37 — *Brachonella spiralis* (120; ; 5 20); 38 — *Pelodinium reniforme* (50; ?; ?); 39 — *Chaenea sapropelica* (100; ?; ?); 40 — *Metopus undulans* (70; ; <2); 41 — *Loxocephalus luridus* (150; ?; ?); 42 — *Metopus curvatus* (60; ; <2); 43 — Scuticociliata; 44 — *Pelomyxa palustris* (100 700; ; > 200); 45 — *Acanthamoeba*, *Vahlkampfia*; 46 — Scuticociliata; 47 — *Stylonychia* (70/130; ; 2 10); 48 — *Aspidisca cicada* (30; ; <2); 49 — 12; 50 — 30; 51 — *Paruroleptus* sp. (130; ; <20); 52 — *Rhagadostoma* sp. (100; ; 5 10); 53 — *Cinetochilum margahtaceum* (30; ; <2); 54 — *Holosticha* sp. (80; ; 2 10); 55 — *Oscillosignum*, *Vahlkampfia*; (25/7; ; 2 5); 56 — *Centropyxis*, *Diffflugia*; ; 57 — *Vorticella*; 58 — (1 5).

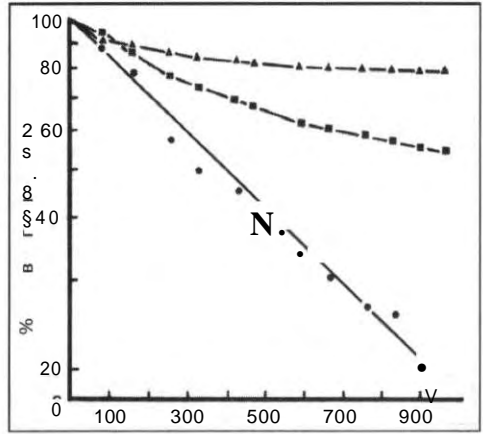
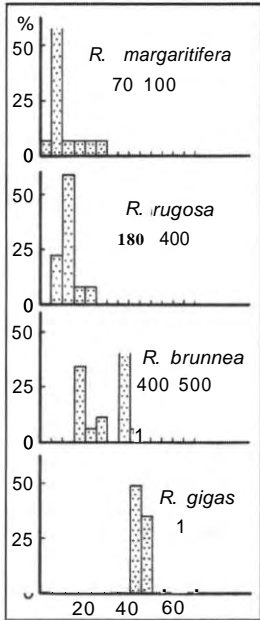

368.

(),

(•),

(•) () .

367.

Remanella.

() .

Ophryoglena
Tetrahymena].

1

(« ») . —

30 (. 369).

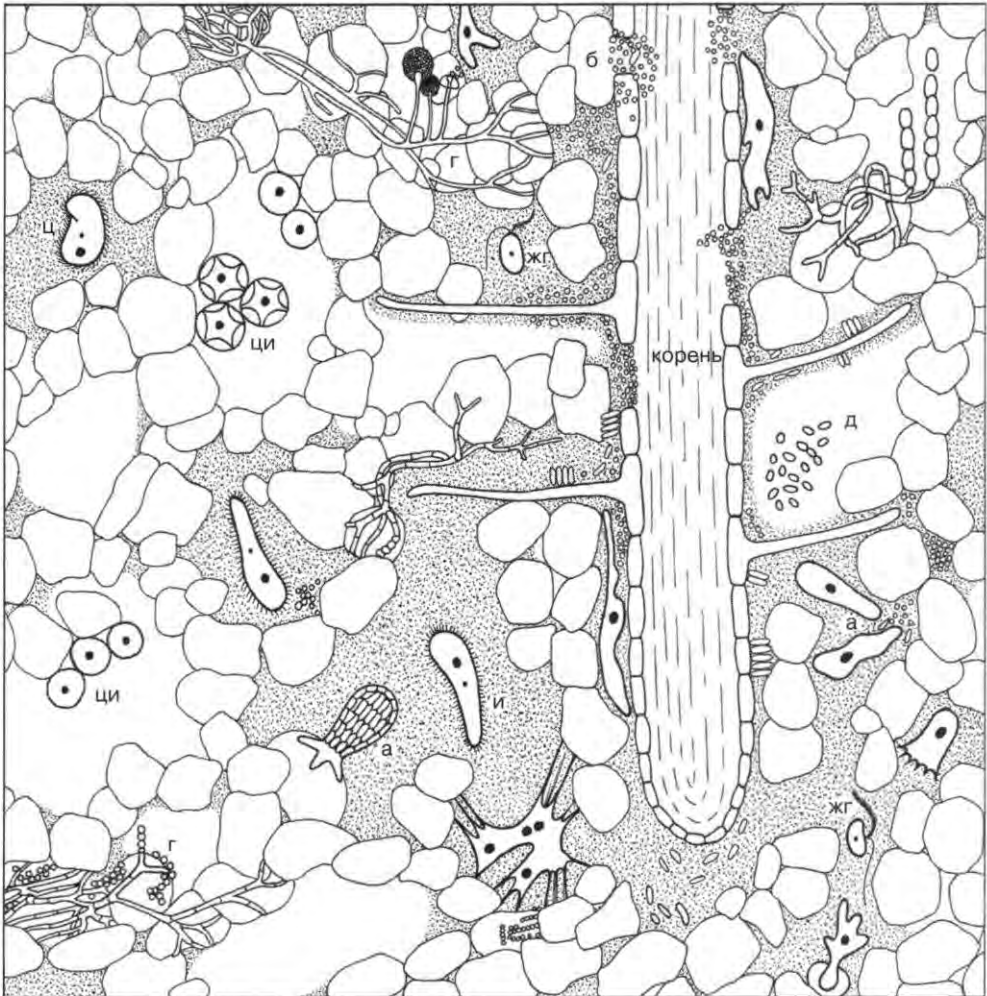

. 369.

() ;

(' -).

5

35 70%

(. 370).

Colpodea, Hypotrichia Prostomatea.

80 90%

10 20%

30%

10—

20

20 200

: 2

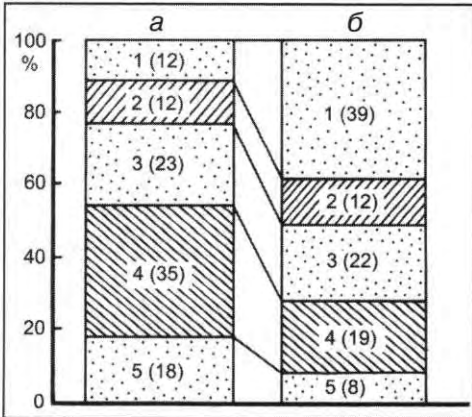

40

(. . 28).

14 000

. 370.

()

). 1 — , 2 —

, 3 — , 4 —

, 5 — ;

).

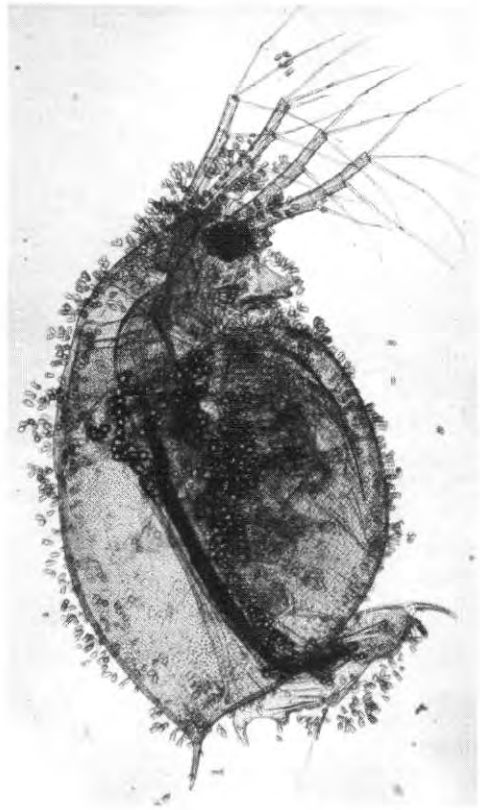

. 371.
 (: Hausmann and Rambow: Mikro
 kosmos 74 [1985] 208). : 50x.

(. 371, 372).

(, *Ichthyophthi*
rius multifiliis, . 139).

1

2

Amphipoda —

Dendrocometes paradoxus —

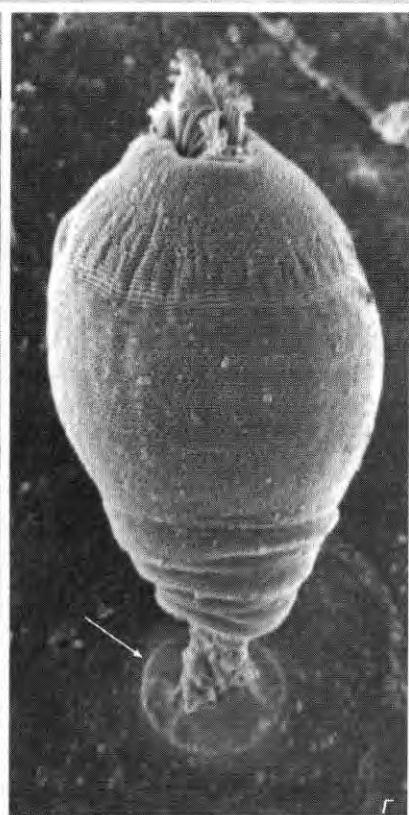
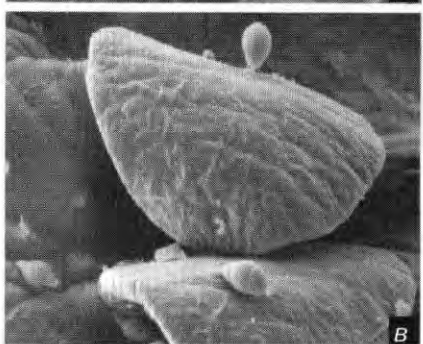
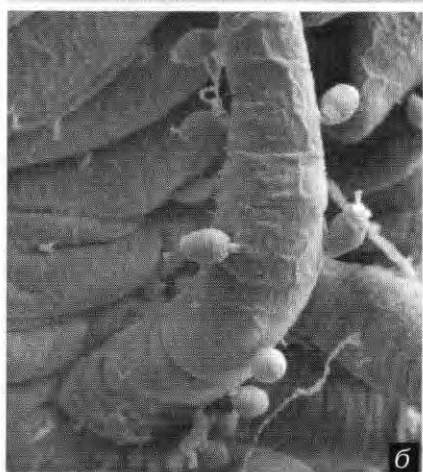
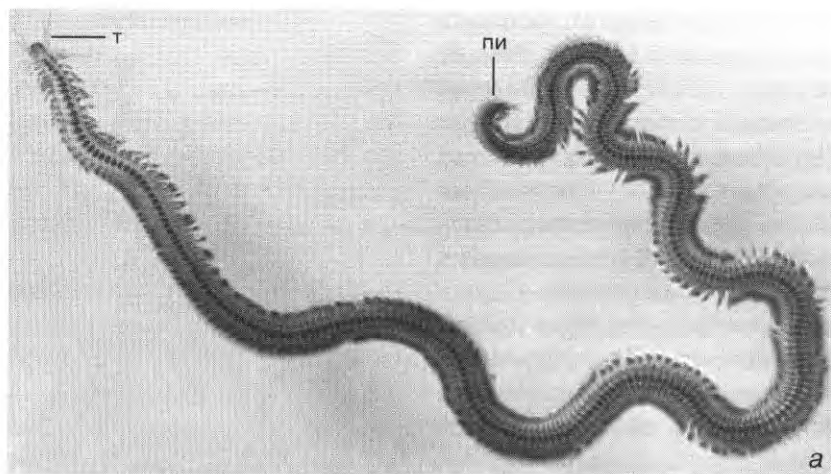

372. *Anaitides mucosa* ()
 () () (,) — — , —
 (: Hausmann: Mikrokosmos 69 [1980] 156). : 2,2 , 180 , —150 , 1 800 .

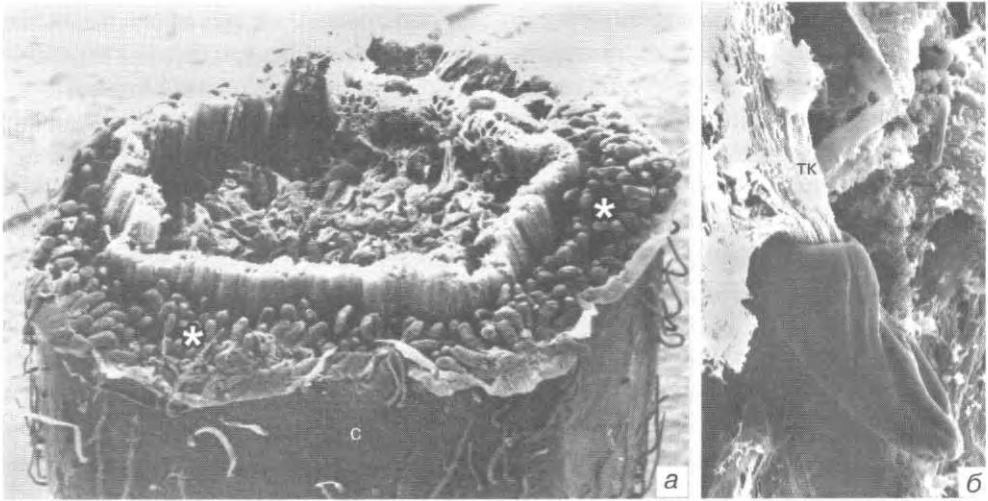

373. () (*Medicago sativa*),
Epidinium (, *);
 () (: Bauchop: Appl. Environ. Microbiol. 37
 [1979] 1217). : a 40x, 350 .

Entodi
 niomorpha (. 126)
 leu
 cocephala,

Metopus,

(— — —) — — — , — — —

(,

).

03

(,)

(,)

(),

02

(. 374).

02,

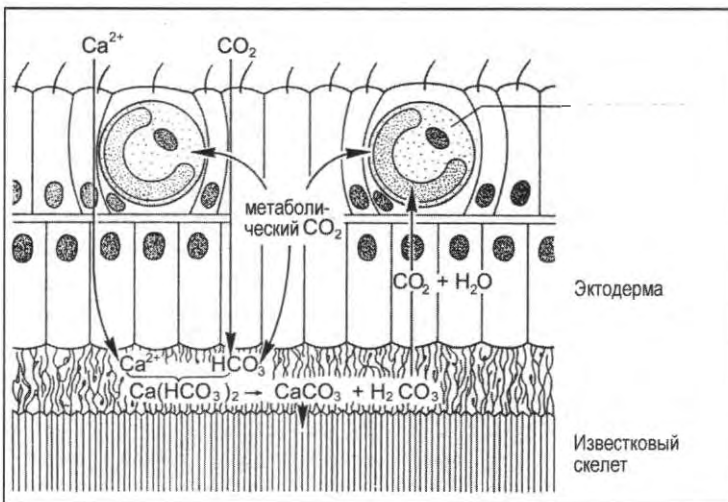

. 374.

(.).

(,)

(,)

(,)

1

2

(,)

« »

Naegleria

Acanthamoeba

1 (0 150)

2

(= *Spiromonas*) *gonderi*,

(. . . 83),

Apicomplexa.

Colpodella

Asterias amurensis

Orchitophrya stellarum.

Cryptosporidium parvum

, a *Pneumocystis* —

(. . . 375, 377).

Paulinella chromatophora.

Chlorella Trebouxia

(. . . 376, 377).

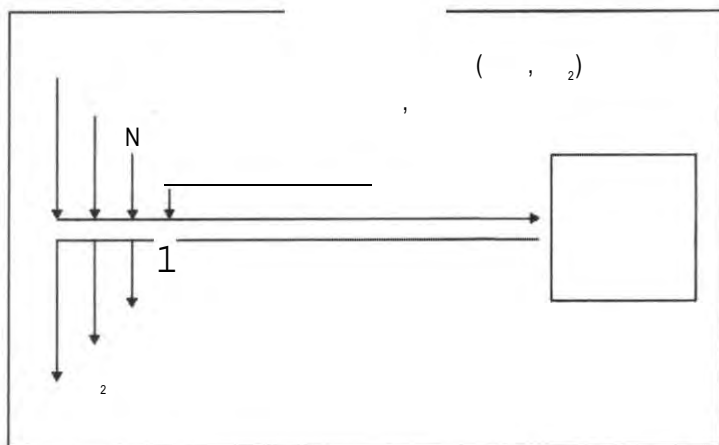

. 375.

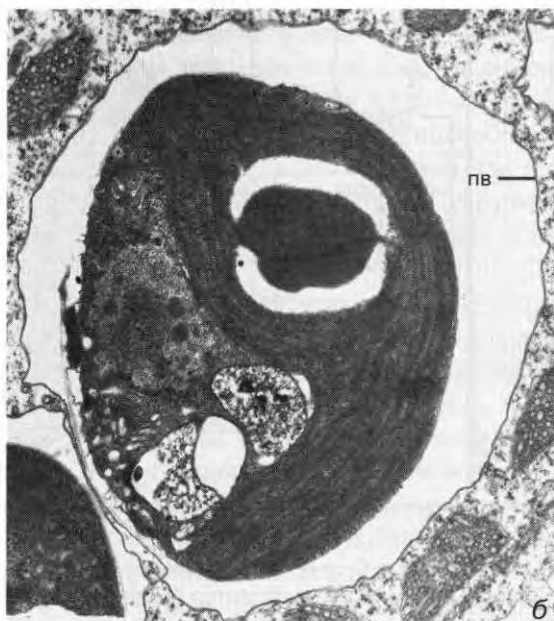
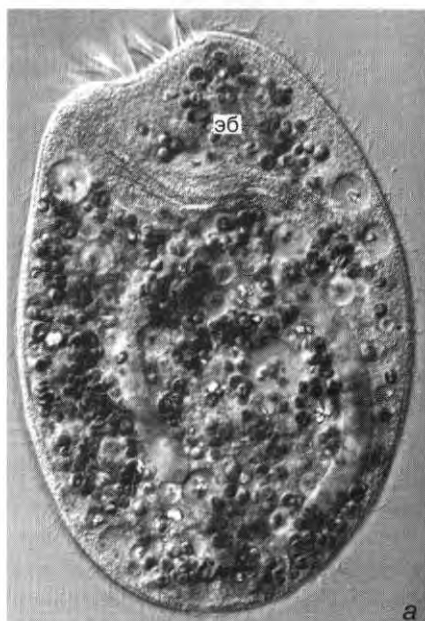

. 376.

Climacostomum virens

Chlorella: —

() (: Reisser et al.: Protoplasma 119 [1984] 93).

.. a — 500x, —

24 000x.

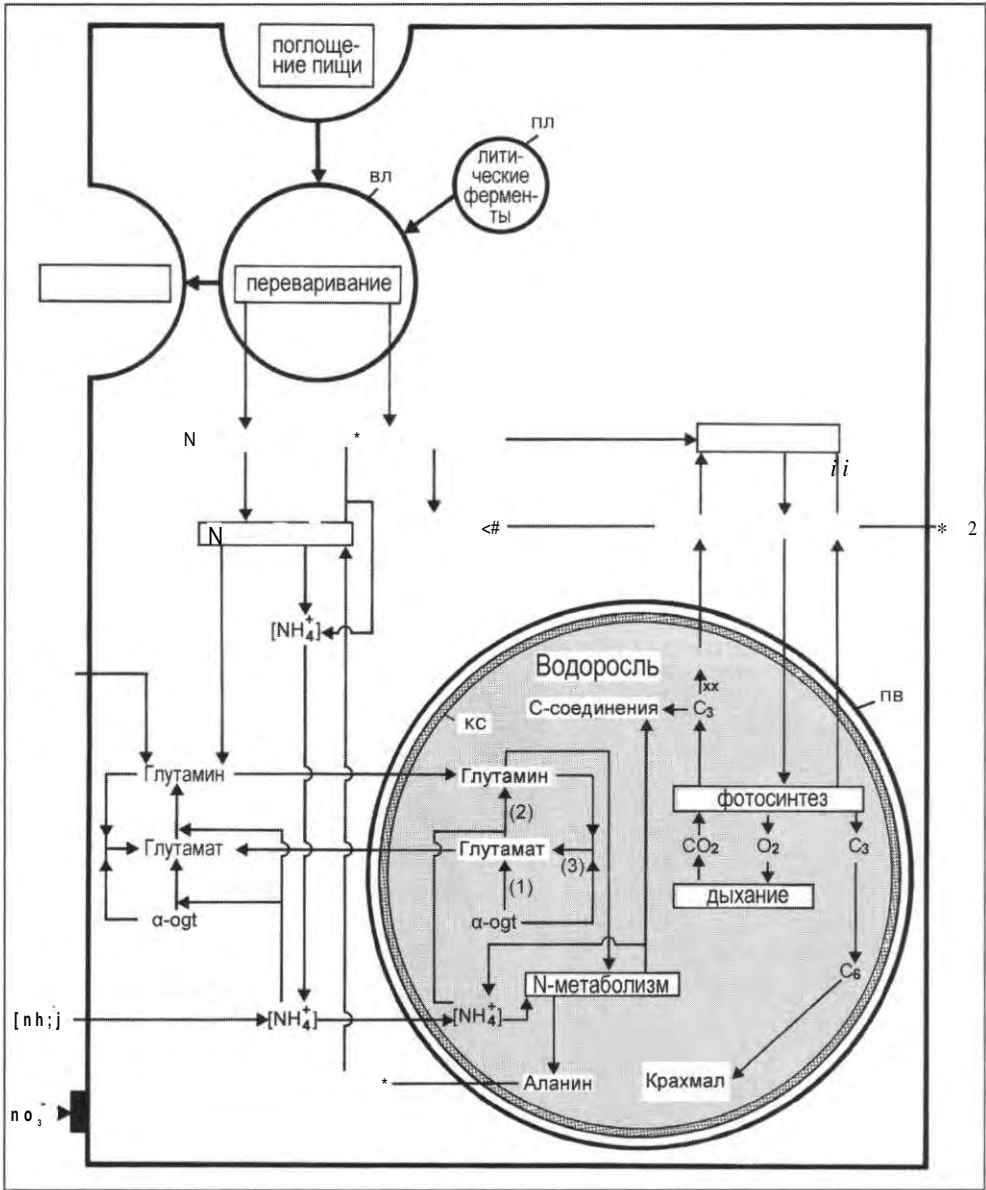

377. *Chlorella* sp.

N

Paramecium bursaria

Chlorella,

, 3 —

, 1 —
, ос ogт —

, 2 —

().

1 *Chlorarachnion*

(. . . 29 31).

Peridinium balticum,

Euplotes aediculatus

(. . . 31).

(*Polynucleobacter necessarius*).

Myrionecta (Mesodinium) rubra (. . . 29).

Paramecium

Paramecium aurelia,

P. aurelia

— « » « »
(«bright» « bright»).

R (refra
ctile) «

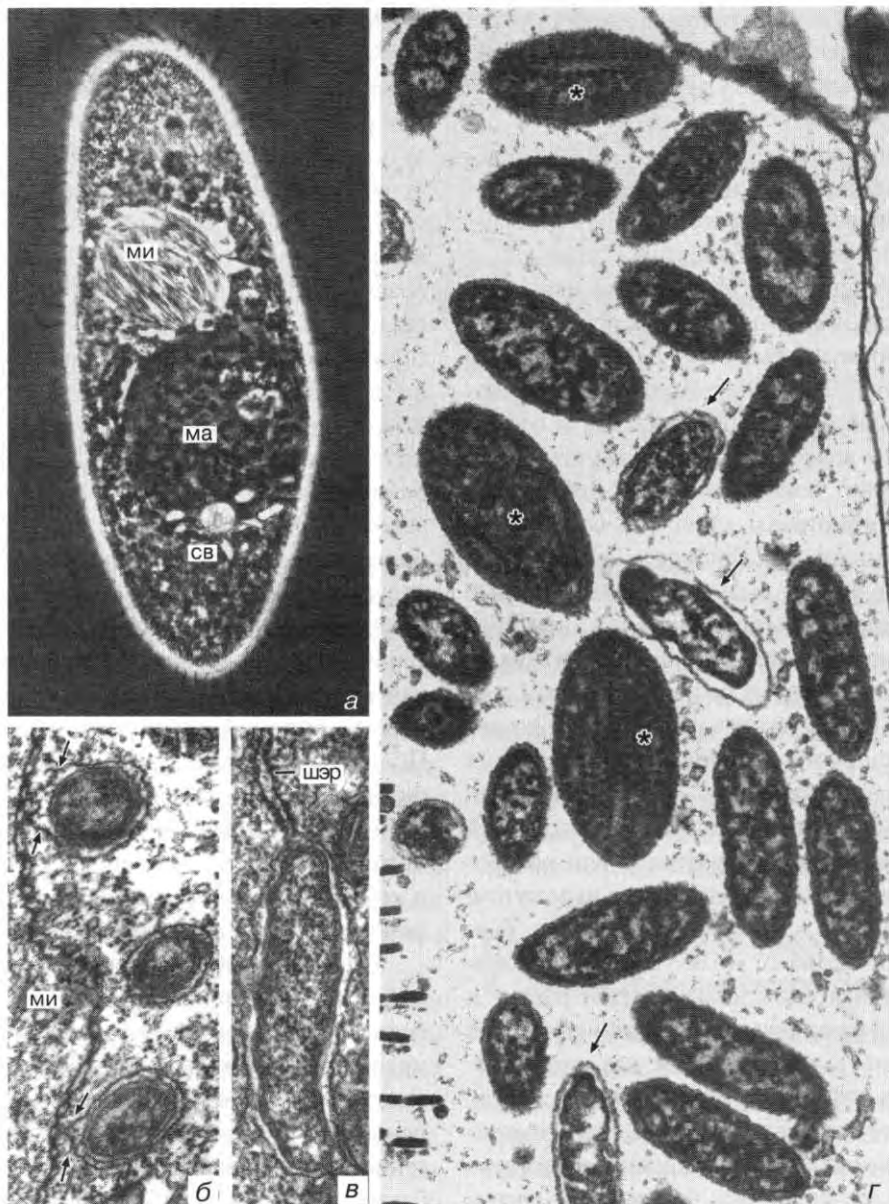

378. *Holospira elegans* () *Paramecium caudatum* ()
Paramecium caudatum () ;
Entosiphon sulcatum () () ;
 () *Trichodina pediculus*,
 (*) () , — (—
 , . : 520 , 14 000 , — 15 000 , 11

13, (*thamoeba castellanii*, *A. palestinensis*, *Hartmanella vermiformis*, *Naegleria* spp.) (, *Tetrahymena thermophila*).

Legionella pneumophila,

Aeromonas salmonicida, *Edwardsiella tarda*, *Listeria monocytogenes*, *Mycoplasma Vibrio cholerae*,

: *Pseudomonas* spp., *Salmonella* spp., *Shigella* spp.

Amoeba proteus, (X

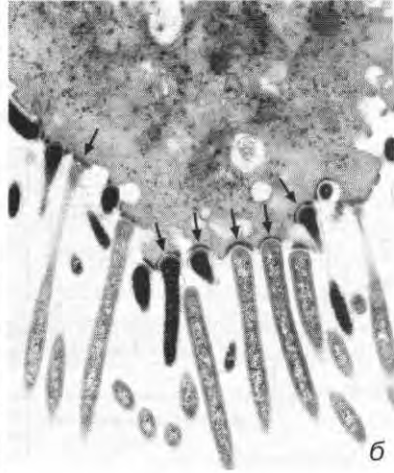
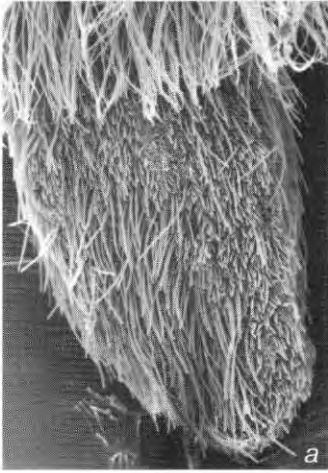

. 379.

Joenia (),

(,
)(: Radek
 and Hausmann: Acta
 Protozool. 31 [1992]
 93). : a 1 000x,
 b 8 000x.

Joenia,

(. 379).

(. 380).

Mixotricha paradoxa

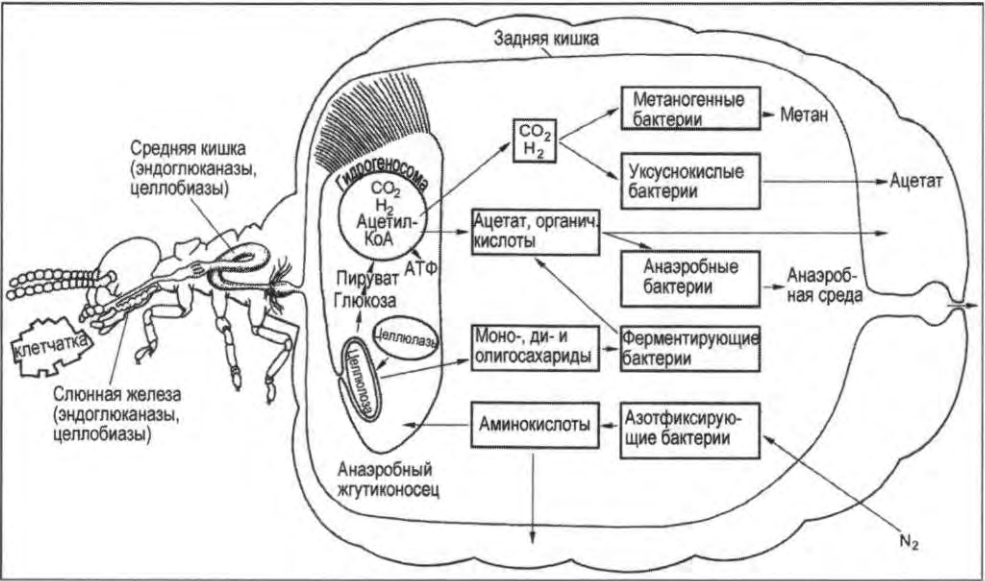

. 380.

(: Radek: Ecotropica 5 [1999] 183).

Heterosigma akashiwo
Phaeocystis

Plasmodiophora
(*Polymyxa*, *Spongospora*)

(peanut clump

), virus),

(potato mop top virus)

(broad bean

myxa Chytridiomycota.

Phyto

necrosis virus).

(oat mosaic virus).
Olpidium brassicae

(tobacco
 (melon

necrosis virus)
 necrotic spot virus).

1)
 (< 1),
 ; 2)

(. 381).
 213
 3 ; 3)

100
 ,

89% (. . « » — everything
 , 65% is everywhere).
 , 55% 1 650
 , 25% , 15% , 95
 , 15% ;
 2,5%
 (,)
 ()
 85%

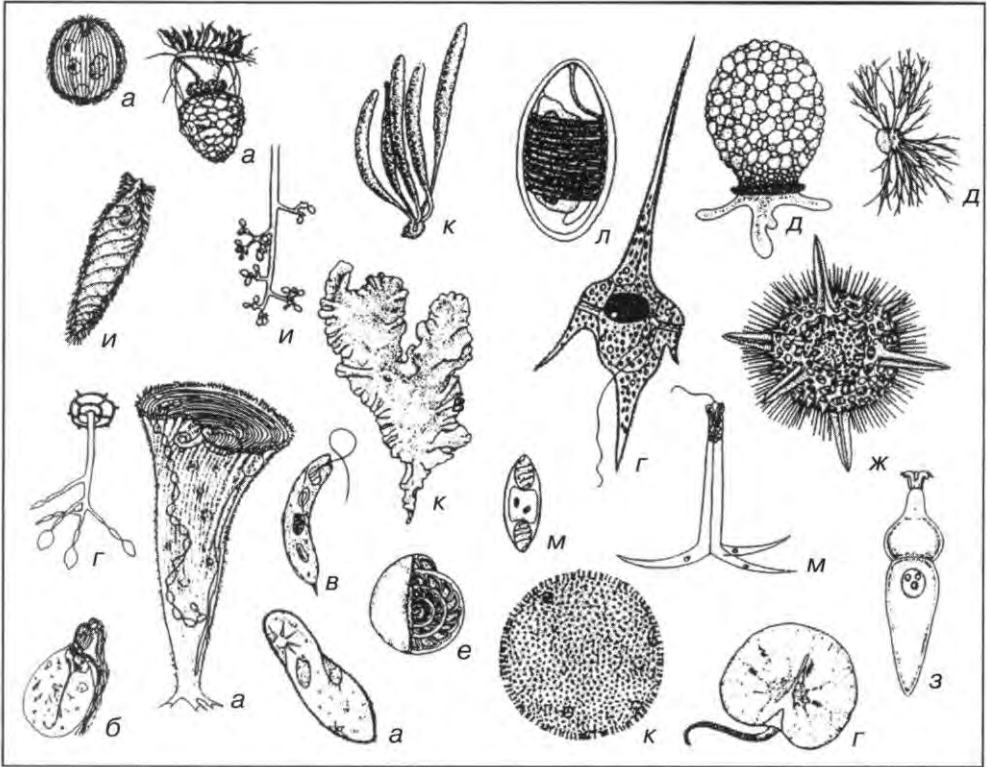

. 381.

); —

(,) ; — ; —

); —

()

(); —

Myxozoa (

) (: Corliss: Acta Protozool. 41 [2002] 199).

15% 30, 50%

30

12 *Tetrahymena*

(. 382); , . *australis*

. *capricornis*

Chaos carolinense Ch.

illinoisense



. 382.

Tetrahymena pyriformis. 1 — . *thermophila*, 2 — . *americanis*, 3 — . *borealis*, 4 — . *cosmopolitana*, 5 — . *pigmentosa*, 6 — . *canadensis*, 7 — . *tropicalis*, 8 — . *hyperangularis*, 9 — . *australis*, 10 — . *capricornis*.

21.

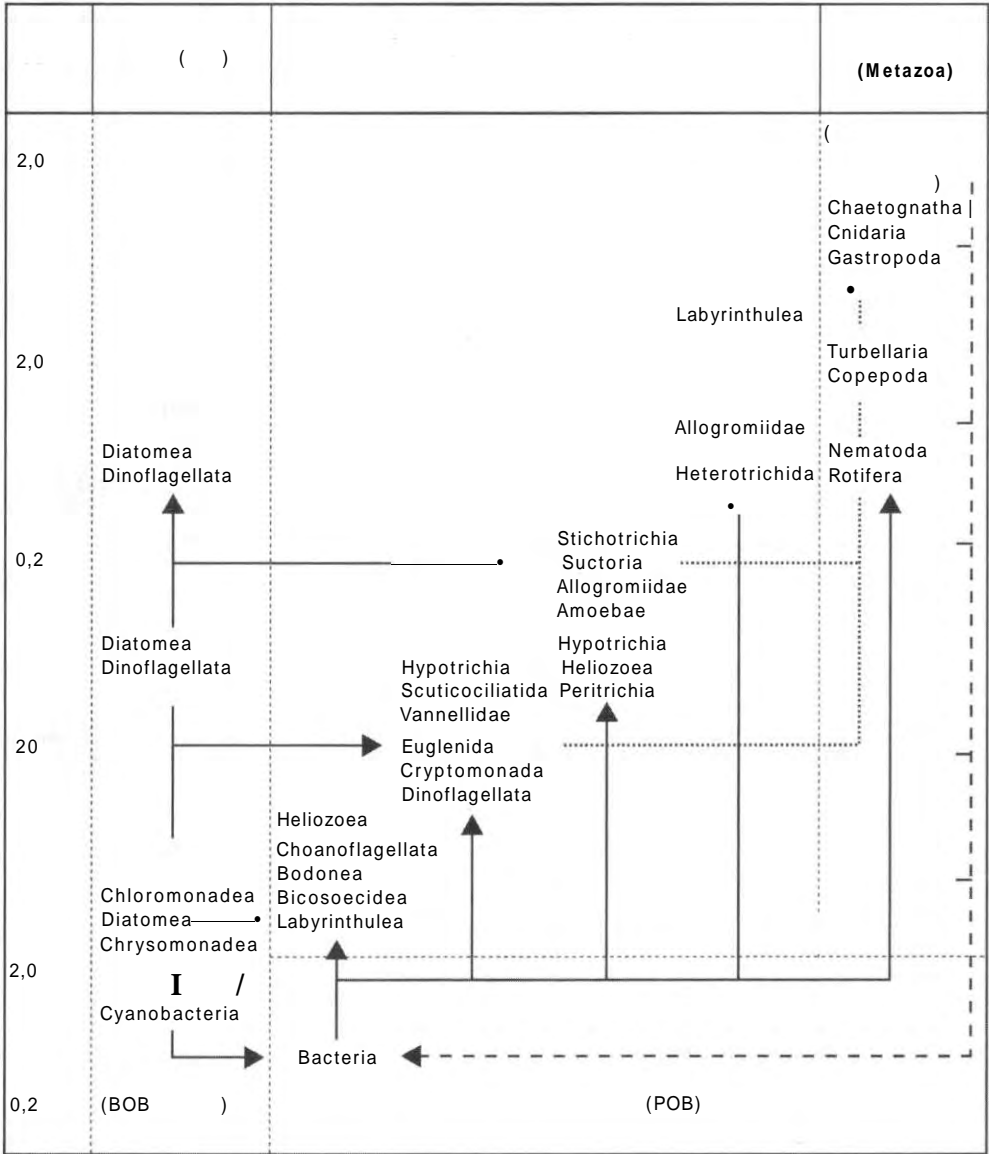

() ;
 ; -
 () (),
 () ,

Folliculina boltoni —

300

Reticulo

filosa —

60 ()

1000
150

1

Odontella
(= *Biddulphia*) *sinensis* *Coscinodiscus*
walesii

XX

1 « » («larger foraminifers») «large foraminifers»
);
;

(), ()
()
()

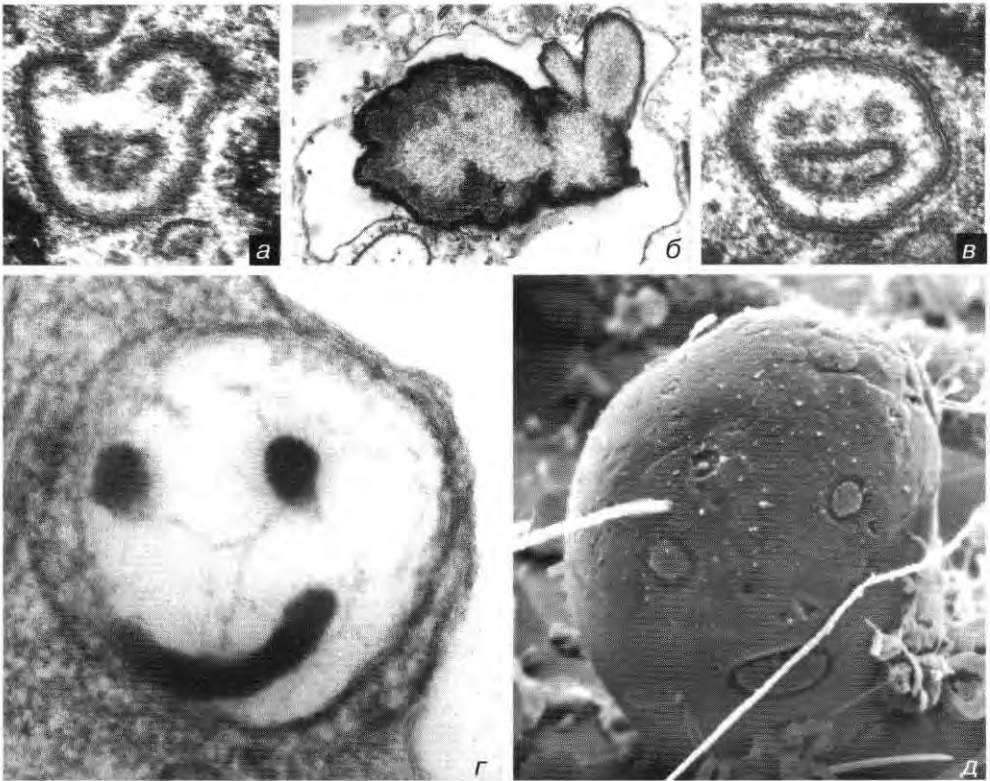

383.
 (,),
Pseudomicrothorax dubius, —
Actinophrys sol, —
 (— 20 , — 80 , 55 , 4

(,)
 (): —
Climacostomum, —
 , () . : — 80 , —

(. 383)...

(. 384).

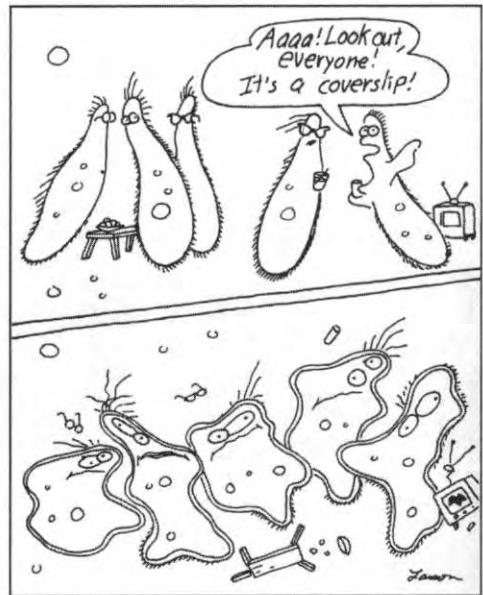

. 384.

- ACTA Protozoologica**, 1963, -
- ARCHIV FÜR PROTISTENKUNDE**, 1901, -
: Gustav Fischer Verlag, -
1998 **PROTIST**, -
Urban & Fischer Verlag, -
- JOURNAL OF PROTOZOLOGY**, 1947, 1993
**JOURNAL OF EUKARYOTIC
MICROBIOLOGY**, -
: Allen Press, -
- PROTISTOLOGICA**, 1965, -
CNRS, - 1987 -
EUROPEAN JOURNAL OF PROTISTOLOGY, -
: Urban & Fischer Verlag, -
- PROTISTOLOGY**, 1999,
« », -
- I: , , 1961.
Ludvik, J., J. Lorn, J. Vavra (eds), Czechoslovak
Academy of Sciences, Prague 1963.
- II: , , 1965.
Neal, R. A. (ed), Excerpta Medica Foundation,
Amsterdam 1965.
- III: , , 1969.
Strelkov, . . . M. Sukhanova, I. B. Raikov
(eds), Nauka, Leningrad 1969.
- IV: , , 1973.
Puytorac, J. de, J. Grain (eds), Paul Couty, Cler-
mont Ferrand 1974.
- V: , , 1977.
Hutner, S. H., L. K. Bleyman (eds), Pace Univer-
sity, New York 1978.
- VI: , , 1981.
Dryl, S., S. L. Kazubski, L. Kuznicki, J. Ploszaj
(eds), Acta Protozoologica, Special Congress
Volume, part I + II, Warsaw 1982 + 1984.
- VII: , , 1985.
Gardiner, P. R., L. H. Otieno (eds), Insect Sci. App
lic, Special Congress Volume, Oxford 1986.
- VIII: , , 1989.
Nozawa, Y. (ed), Zoological Science, Supplement,
Daigaku Letterpress, Hiroshima 1990.
- IX: , , 1993.
Hausmann, ., N. Hülsmann (eds), Gustav Fischer
Verlag, Stuttgart 1994.
- Bradbury, S.: The microscope. Past and present.
Pergamon, Oxford 1968.
- Corliss, J. O.: A salute to fifty four great micro
scopists of the past: a pictorial footnote to the
history of protozoology. Trans. Amer. Micros.
Soc. 97 (1978) 419; 98 (1979) 26.
- Corliss, J. O.: Historically important events,
discoveries, and works in protozoology from
the mid 17th to the mid 20th century. Rev.
Soc. . Hist. Nat. 42 (1991) 45.
- Dobell, C: Antony van Leeuwenhoek and his
«little animals». Bale, Sons & Danielsson,
London 1932.
- Ford, B. J.: The Leeuwenhoek legacy. Biopress,
Bristol 1991.
- Vickerman, ., M. Sleight, B. Leadbeater,
S. McCready: A century of protozoology in
Britain. The British Section of the Society of
Protozoologists, 2000.
- Wolf, M., K. Hausmann: Protozoology from the
perspective of science theory — History and
concept of a biological discipline. Linzer
biol. Beitr. 33 (2001) 461.
- Anderson, O. R.: Comparative protozoology.
Ecology, physiology, life history. Springer
Verlag, Berlin 1987.

- Biltschli, .: Protozoa. In: Bronn, H. G. (Hrsg): Klassen und Ordnungen des Tierreichs. Winter, Heidelberg 1880 1889.
- Chen, .: Research in protozoology, vol. I IV. Pergamon, New York 1967 1972.
- Coombs, G. H., M. J. North (eds): Biochemical protozoology. Taylor & Francis, New York 1991.
- Doflein, F., E. Reichenow: Lehrbuch der Protozoenkunde, 6. Aufl. Gustav Fischer Verlag, Jena 1949 1953.
- Dogiel, V. A. (revised by J. I. Poljanski, E. M. Chejsin): General protozoology, 2nd ed. Clarendon, Oxford 1965.
- Farmer, J. N.: The protozoa. Introduction to protozoology. Mosby, St. Louis 1980.
- Grassé, P. R: Protozoaires. In: Traité de Zoologie, vol. I, 1+2, and II, 1+2. Masson, Paris 1952/1953, 1984, 1994.
- Grell, K. G: Protozoology, 3rd ed. Springer Verlag, Berlin 1973.
- Harrison, F. W., J. O. Corliss (eds): Protozoa. In: F. W. Harrison (ed): Microscopic anatomy of invertebrates, vol. 1. Wiley Liss, New York 1991.
- Hyman, L. H.: The invertebrates, vol. 1: Protozoa through Ctenophora. McGraw Hill, New York 1940.
- Kidder, G. W.: Protozoa. In: I. M. Florin, . T. Scheer (eds): Chemical zoology, vol. 1. Academic Press, London 1967.
- Kudo, R. R.: Protozoology, 6th ed. Thomas, Springfield 1971.
- Levandowsky, M., S. H. Hutner: Biochemistry and physiology of protozoa, vol. I IV. Academic Press, London 1979 1981.
- Lipps, J. H. (ed): Fossil prokaryotes and protists. Blackwell Scientific Publications, London 1993.
- Mackinnon, D. L., R. S. J. Hawes: An introduction to the study of protozoa. Clarendon, Oxford 1961.
- Margulis, L., J. O. Corliss, M. Melkonian, D. J. Chapman (eds): Handbook of protozoology. Jones & Bartlett, Boston 1990.
- Margulis, L., H. I. McKhann, L. Olendzenski (eds): Illustrated glossary of protozoology. Jones & Bartlett, Boston 1993.
- Mehlhorn, H., A. Ruthmann: Allgemeine Protozoologie. Gustav Fischer Verlag, Jena 1992.
- Puytorac, de P., J. Grain, J. P. Mignot: Précis de protistologie. Boubee, Paris 1987.
- Sleigh, M.: Protozoa and other protists, 2nd ed. Arnold, London 1989 (first published as «The biology of protozoa», 1973).
- Wenyon, . M. Protozoology. Balliere, Tindall & Cox, London 1926.
- Anderson, D. ., A. W. White, D. G. Baden (eds): Toxic dinoflagellates. Elsevier Science Publisher, Amsterdam 1986.
- Berner, T (ed): Ultrastructure of microalgae. CRC Press, Boca Raton 1993.
- Bold, H. ., M. J. Wynne: Introduction to the algae. Structure and reproduction. Prentice Hall, Englewood Cliffs 1978.
- Bourrelly, P.: Les algues d'eau douce, tome I—III. Boubee, Paris 1966 1970.
- Cox, E. R. (ed): Phytoflagellates. Elsevier Science Publishers, Amsterdam 1980.
- Dodge, J. D.: The fine structure of algal cells. Academic Press, London 1973.
- Fott, .: Algenkunde, Gustav Fischer Verlag, Jena 1959.
- Green, J. ., B. S. C. Leadbeater (eds): The haptophyte algae. Oxford University Press, Oxford 1994.
- Green, J. ., B. S. C. Leadbeater W. L. Diver (eds): The chromophyte algae: problems and perspectives. Clarendon Press, Oxford 1989.
- Hoek, C. van den, D. G. Mann, H. M. Jahns: Algae. Cambridge University Press, Cambridge 1995.
- Leadbeater, B. S. C., J. C. Green (eds): The flagellates — Unity, diversity and evolution. Taylor & Francis, London 2000.
- Moestrup, O.: Flagellar structure in algae — A review, with new observations particularly on the Chrysophyceae, Phaeophyceae (Fuco phyceae), Euglenophyceae, and *Reckertia*. Phycologia 21 (1982) 427.

- Patterson, D. J., J. Larsen: The biology of free living heterotrophic flagellates. Clarendon Press, Oxford 1991.
- Pickett Heaps, J. D.: Green algae — Structure, reproduction and evolution in selected genera. Sinauer, Sunderland 1975.
- Pringsheim, E. G.: Farblose Algen — Ein Beitrag zur Evolutionsforschung. Gustav Fischer Verlag, Jena 1963.
- Round, F. E.: The ecology of algae. Cambridge University, Cambridge 1983.
- Spector, D. L.: Dinoflagellates. Academic Press, London 1984.
- Taylor, F. J. R. (ed): The biology of dinoflagellates. Blackwell Scientific Publications, Oxford 1987.
- Tomas, C. R. (ed): Marine phytoplankton: a guide to naked flagellates and coccolithophorids. Academic Press, London 1993.
- Wiessner, W., D. G. Robinson, R. C. Starr (eds): Algal development — Molecular and cellular aspects. Springer Verlag, Berlin 1987.
- Anderson, O. R.: Radiolaria. Springer Verlag, Berlin 1983.
- Boltovsky, E., R. Wright: Recent Foraminifera. Junk, The Hague 1976.
- Hedley, R. H., C. G. Adams: Foraminifera, vol. I + II. Academic Press, London 1974 1978.
- Hemleben, C.H., M. Spindler, O. R. Anderson: Modern planktonic Foraminifera. Springer Verlag, Berlin 1989.
- Jones, R. W.: The Challenger Foraminifera. Oxford University Press, Oxford 1994.
- Lee, J. J., O. R. Anderson: Biology of Foraminifera. Academic Press, London 1991.
- Loeblich, A. R., H. Tappan: Foraminiferal genera and their classification, part I + II. Chapman & Hall, New York 1988.
- Martinez, A. J.: Free living amebas: natural history, prevention, diagnosis, pathology, and treatment of disease. CRC Press, Boca Raton 1985.
- Murray, J. W.: Ecology and palaeoecology of benthic Foraminifera. Wiley & Sons, New York 1991.
- Page, F. C., F. J. Siemensma: Nackte Rhizopoden und Heliozoa. In: D. Matthes (Hrsg): Protozoenfauna, Vol. 2. Gustav Fischer Verlag, Stuttgart 1991.
- Rondanelli, E.G. (ed): Amphizoic amoebae. Human pathology. Piccin, Padova 1987.
- Takahashi, K.: Radiolaria: flux, ecology, and taxonomy in the Pacific and Atlantic. Woods Hole Oceanogr. Inst., Ocean Biocoenosis, Series No. 3, Woods Hole 1991.
- Davies, S. F. M., L. P. Joyner, S. B. Kendall: Coccidiosis. Oliver & Boyd, London 1963.
- Dubey, J. P., C. A. Speer, R. Fayer (eds): Sarcocystosis of animals and men. CRC Press, Boca Raton 1989.
- Garnham, P. C.: Malaria parasites and other haemosporidia. Blackwell, Oxford 1966.
- Hammond, D. M., P. L. Long: Coccidia: *Eimeria*, *Isospora*, *Toxoplasma*, and related genera. University Park, Baltimore 1973.
- Kreier, J. P.: Malaria, vol. I—III. Academic Press, London 1980.
- Levine, N. D.: Protozoan parasites of domestic animals and of man, 2nd ed. Burgess, Minneapolis 1973.
- Levine, N. D.: The protozoan phylum Apicomplexa, vol. I + II. CRC Press, Boca Raton 1988.
- Long, P. L.: The biology of Coccidia. Arnold, London 1982.
- Long, P. L.: Coccidiosis of man and domestic animals. CRC Press, Boca Raton 1990.
- Ristic, M. (ed): Babesiosis of domestic animals and man. CRC Press, Boca Raton 1988.
- Scholtyssek, E.: Fine structure of parasitic protozoa. Springer Verlag, Berlin 1979.
- Aescht, E.: Catalogue of the generic names of ciliates (Protozoa, Ciliophora). Denisia 1 (2001) 1.
- Berger, H.: Catalogue of ciliate names — 1. Hypotrichs. Verlag Helmut Berger, Salzburg 2001.
- Corliss, J. O.: The ciliated protozoa — Characterization, classification and guide to the literature, 2nd ed. Pergamon, Oxford 1979.

- Curds, J. R.: British and other freshwater ciliated protozoa, Part I. Ciliophora: Kinetofragminophora. In: D. M. Kermack, R. S. K. Barnes (eds): *Synopsis of the British fauna*. Cambridge University, Cambridge 1982.
- Curds, C. R., M. A. Gates, D. McL. Roberts: British and other freshwater ciliated protozoa, Part II. Ciliophora: Oligohymenophora and Polyhymenophora. In D. M. Kermack, R. S. K. Barnes (eds): *Synopsis of the British fauna*. Cambridge University, Cambridge 1983.
- Dragesco, J.: Cilies libres du Cameroun. Ann. Fac. Sci. Yaounde, Yaounde 1970.
- Dragesco, J., A. Dragesco Kerneis: Cilies mesopsammiques littoraux. Systematique, morphologie, ecologie. Trav. Stat. Biol. Roscoff (N. S.) 12 (1960) 1.
- Dragesco, J., A. Dragesco Kerneis: Cilies libres de l'Afrique intertropicale. Editions de l'ORSTOM, Paris 1986.
- Fenchel, T., J. Finlay: The biology of free living anaerobic ciliates. *Europ. J. Protistol.* 26 (1991) 201.
- Foissner, W., S. Agatha, H. Berger: Soil ciliates (Protozoa, Ciliophora) from Namibia (South-west Africa), with emphasis on two contrasting environments, the Etosha Region and the Namib Desert. *Denisia* 5 (2002) 1.
- Gall, J. G. (ed): *The molecular biology of ciliated protozoa*. Academic Press, London 1986.
- Hausmann, G., P. C. Bradbury (eds): *Ciliates: cells as organisms*. Gustav Fischer Verlag, Stuttgart 1996.
- Jones, A. R.: *The ciliates*. Hutchinson, London 1974.
- Lynn, D. H.: The organization and evolution of microtubular organelles in ciliated protozoa. *Biol. Rev.* 56 (1981) 243.
- Lynn, D. H., E. B. Small: A revised classification of the phylum Ciliophora Doflein, 1901. *Rev. Soc. Hist. Nat.* 47 (1997) 65.
- Matthes, D., W. Guhl, G. Haider: Suctorina und Urceolariidae (Peritricha). In: Matthes, D. (Hrsg): *Protozoenfauna*, vol. 7, 1. Gustav Fischer Verlag, Stuttgart 1988.
- Petz, W., W. Song, N. Wilbert: Taxonomy and ecology of the ciliate fauna (Protozoa, Ciliophora) in the endopagial and pelagial of the Weddel Sea, Antarctica. *Stapfia* 40 (1995) 1.
- Acanthamoeba**
- Byers, B. J.: Growth, reproduction and differentiation in *Acanthamoeba*. *Int. Rev. Cytol.* 61 (1979) 283.
- Amoeba**
- Jeon, K. W.: *The biology of Amoeba*. Academic Press, London 1973.
- Blepharisma**
- Giese, A. C.: *Blepharisma* — The biology of a light sensitive protozoon. Stanford University, Stanford 1973.
- Chlamydomonas**
- Harris, E. H.: *The Chlamydomonas sourcebook* — A comprehensive guide to biology and laboratory use. Academic Press, London 1989.
- Cryptosporidium**
- Dubey, J. P., C. A. Speer, R. Fayer: *Cryptosporidiosis of man and animals*. CRC Press, Boca Raton, Florida 1990.
- Fayer, D. (ed): *Cryptosporidium and cryptosporidiosis*. CRC Press, Boca Raton 1997.
- Tzipori, S., Widmer, G.: The biology of *Cryptosporidium*. *Contrib. Microbiol.* 6 (2000) 1.
- Dasycladales**
- Berger, S., M. J. Kaefer: *Dasycladales* — An illustrated monograph of a fascinating algal order. Thiem Verlag, Stuttgart 1992.
- Dictyostelida**
- Kessin, R. H.: *Dictyostelium* — Evolution, cell biology, and the development of multicellularity. Cambridge University Press, Cambridge 2001.
- Raper, J. B.: *The dictyostelids*. Princeton University Press, Princeton 1984.

Entamoeba

Ravdin, J. (ed): Amebiasis Human infection by *Entamoeba histolytica*. Churchill, Livingstone 1988.

Euglena

Buetow, D. E.: The biology of *Euglena*, vol. I IV. Academic Press, London 1968 1989.

Gojdics, M.: The genus *Euglena*. University of Wisconsin, Madison 1953.

Leedale, G. F.: Euglenoid flagellates. Prentice Hall, Englewood Cliffs 1967.

Leedale, G. F.: The euglenoids. Oxford University Press, Oxford 1971.

Wolken, J. J.: *Euglena*. An experimental organism for biochemical and biophysical studies, 2nd ed. Appleton, New York 1967.

Folliculinidae.

Hadzi, J.: Studien uber Follikuliniden. Dela Slov. Akad. Znan. Umet. Hist. Nat. Med. 4 (1951) 1.

Giardia

Meyer, E. A. (ed): Giardiasis. Elsevier Science Publishers, Amsterdam 1990.

Thompson, R. C. A., J. A. Reynoldson, A. J. Lymbery (eds): *Giardia*: from molecules to diseases. CAB International, Oxon 1994.

Kinetoplastida

Lumsden, W. H. R., D. A. Evans: Biology of the Kinetoplastida, vol. I + II. Academic Press, London 1976 + 1979.

Mallomonas

Siver, P. A.: The biology of *Mallomonas* — Morphology, taxonomy and ecology. Kluwer Academic Publishers, Dordrecht 1991.

Microsporidia

Bulla, L., C. Cheng: Comparative Pathology, vol. I: Biology of the Microsporidia, vol. II: Systematics of the Microsporidia. Plenum, London 1976, 1977.

Canning, E. U., J. Lom: The Microsporidia of vertebrates. Academic Press, London 1986.

Sprague, W.: Systematics of the Microsporidia. Plenum, New York 1977.

Weiser, J.: Die Mikrosporidien als Parasiten der Insekten. In: Zwölfer, W. (Hrsg): Monographien zur Angewandten Entomologie, Nr. 17. Paul Parey, Hamburg 1961.

Naegleria

de Jonckheere, J. E.: A century of research on the amoeboflagellate genus *Naegleria*. Acta Protistologica 41 (2002) 309.

John, D.: Primary amebic meningoencephalitis and the biology of *Naegleria fowleri*. Ann. Rev. Microbiol. 36 (1982) 101.

Opaline

Metcalf, M. M.: The opalinid ciliate infusorians. Smithsonian Institution, Bulletin 120, Washington 1923.

Metcalf, M. M.: Further studies on the opalinid ciliate infusorians and their hosts. Proceedings of the United States National Museum 87 (1940) 465.

Ophryoglena

Canella, M. E., I. Rocchi Canella: Biologie des *Ophryoglena* (cilies hymenostomes histophages). Ann. Univ. Ferrara 3 (1976) 1.

Oxytrichidae

Berger, H.: Monograph of the Oxytrichidae (Ciliophora, Hypotrichia). Kluwer Academic Publishers, Dordrecht 1999.

Paramecium

Ehret, C. F., G. de Haller: Origin, development, and maturation of organelles and organelle systems of the cell surface in *Paramecium*. J. Ultrastruct. Res., Suppl. 6 (1963) 1.

Görtz, H. D.: *Paramecium*. Springer Verlag, Berlin 1988.

Janisch, R.: Biomembranes in the life and regeneration of *Paramecium*. Purkyne University, Brno 1987.

Jurand, A., G. G. Selman: The anatomy of *Paramecium aurelia*. Macmillan St. Marin's Press, New York 1969.

Kalmus, H.: *Paramecium* — Das Pantoffeltierchen. Gustav Fischer Verlag, Jena 1931.

van Wagtendonk, W. J.: *Paramecium* — A current survey. Elsevier Science Publishers, Amsterdam 1974.

Wichterman, R.: The biology of *Paramecium*, 2nd ed. Plenum, New York 1986.

Pneumocystis

Cushion, M.: *Pneumocystis carinii*. In: Collier, L., A. Balows, M. Sussmann (eds): Topley and Wilson's microbiology and microbial infections, vol. 4. Oxford University Press, New York 1998.

Hopkin, J. M.: *Pneumocystis carinii*. Oxford University Press, Oxford 1991.

Walzer, P. D.: *Pneumocystis carinii* pneumonia, 2nd ed. Marcel Dekker, New York 1994.

Stentor

Tartar, V.: The biology of *Stentor*. Pergamon, Oxford 1961.

Tetrahymena

Asai, D. J., J. D. Forney (eds): *Tetrahymena thermophila*. Academic Press, London 2000.

Elliott, A.: The biology of *Tetrahymena*. Dowden, Hutchinson & Ross, Stroudsburg 1973.

Hill, D. L.: The biochemistry and physiology of *Tetrahymena*. Academic Press, London 1972.

Nilsson, J. R.: Physiological and structural studies on *Tetrahymena pyriformis* GL. C. R. Lab. Carlsberg 40 (1976) 215.

Toxoplasma

Dubey, J. P., C. P. Beattie: Toxoplasmosis of animals and man. CRC Press, Boca Raton 1988.

Kulda, J., J. Cerkasov (eds): Trichomonads and trichomoniasis. Acta Universitatis Carolinae — Biologica 30 (1986) 177.

Trypanosoma

Black, S. J., J. R. Seed (eds): The African trypanosomes. Kluwer Academic Publishers, Boston 2001.

Englund, P., S. L. Hajduk, J. C. Marini: The molecular biology of trypanosomes. Ann. Rev. Biochem. 51 (1982) 695.

Gibson, W.: Sex and evolution in trypanosomes. Int. J. Parasitol. 31 (2001) 643.

Hoare, C. A.: The trypanosomes of mammals. Blackwell Scientific Publisher, Oxford 1972.

Suza, W. de.: Cell biology of *Trypanosoma cruzi*. Int. Rev. Cytol. 86 (1984) 197.

Urceolariidae

Haider, G.: Monographie der Familie Urceolariidae (Ciliata, Peritricha, Mobilida) mit besonderer Berücksichtigung der im süddeutschen Raum vorkommenden Arten. Parasitol. Schr. Reihe 17 (1964) 1.

Winter, A., W. G. Siesser (eds): Coccolithophores. Cambridge University Press, Cambridge 1994.

Foissner, W.: Class Colpodea (Ciliophora). In: Matthes, D. (Hrsg): Protozoenfauna, Vol. 4/1. Gustav Fischer Verlag, Stuttgart 1993.

Olive, L. S.: The myxozoa. Academic Press, London 1975.

Kent, M. L., B. Andree, J. L. Bartholomew, M. El Matbouli, S. S. Desser, R. H. Devlin, S. W. Feist, R. P. Hedrick, R. W. Hoffmann, J. Khattra, S. L. Hallett, R. J. G. Lester, M. Longshaw, O. Palenzeula, M. E. Siddall, C. Xiao: Recent advances in our knowledge of the Myxozoa. J. Eukaryot. Microbiol. 48 (2001) 395 413.

Duff, B. A. Zeeb, J. P. Smol: Atlas of chrysophycean cysts, vol. I. Kluwer Academic Publishers, Dordrecht, 1995.

Kristiansen, J., R. A. Andersen (eds.): Chrysophytes: aspects and problems. Cambridge University Press, Cambridge 1986.

Kristiansen, J., G. Cronberg (eds): Chrysophytes: progress and new horizons. Nova Hedwigia Beih. 114 (1996) 1.

- Kristiansen, J., G. Cronberg, U. Geissler (eds): Chrysophytes: developments and perspectives. *Nova Hedwigia Beih.* 95 (1989) 1.
- Sandgren, C. D., J. P. Smol, J. Kristiansen (eds.): Chrysophyte algae: ecology, phylogeny and development. Cambridge University Press, Cambridge 1995.
- Wilkinson, A. N., B. A. Zeeb, J. P. Smol: Atlas of chrysophycean cysts, vol. II. Kluwer Academic Publishers, Dordrecht, 2001.
- Cavalier Smith, T.: Eukaryote kingdoms: seven or nine? *BioSystems* 14 (1981) 461.
- Cavalier Smith, T.: Kingdom Protozoa and its 18 phyla. *Microbiol. Rev.* (1993) 953.
- Cavalier Smith, T. A revised six kingdom system of life. *Biol. Rev.* 73 (1998) 203.
- Corliss, J. O.: An interim utilitarian («user friendly») hierarchical classification and characterization of the protists. *Acta Protozool.* 33 (1994) 1.
- Corliss, J. O.: Biodiversity, classification, and numbers of species of protists. In: Raven, P. H., T. Williams (eds): *Nature and human society — The quest for a sustainable world.* National Academic Press, Washington 2000.
- Corliss, J. O.: Biodiversity and biocomplexity of the protists and an overview of their significant roles in maintenance of our biosphere. *Acta Protozool.* 41 (2002) 199.
- Grell, K. G.: Unterreich Protozoa, Einzeller oder Urtiere. In: Gruner, H. E. (Hrsg): *Lehrbuch der Speziellen Zoologie.* 5. Aufl. Gustav Fischer Verlag, Stuttgart 1993.
- Honigberg, M., E. C. Bovee, J. O. Corliss, M. Gojdics, R. P. Hall, R. R. Kudo, N. D. Levine, A. R. jr. Loeblich, J. Weiser, H. D. Wenrich: A revised classification of the phylum Protozoa. *J. Protozool.* 11 (1964) 7.
- Levine, N. D., J. O. Corliss, F. E. G. Cox, G. Deroux, J. Grain, M. Honigberg, G. F. Leedale, A. R. Loeblich III, J. Lom, D. Lynn, E. G. Merinfeld, F. C. Page, G. Poljanski, V. Sprague, J. Vavra, F. G. Wallace: A newly revised classification of the protozoa. *J. Protozool.* 27 (1980) 37.
- Patterson, D. J.: The diversity of eukaryotes. *The American Naturalist* 65 (1999) S96.
- Coombs, G. H., K. Vickerman, M. A. Sleigh and A. Warren (eds): *Evolutionary relationships among protozoa.* Kluwer Academic Publishers, Dordrecht 1998.
- Gibbs, S. R.: The chloroplast endoplasmatic reticulum: structure, function, and evolutionary significance. *Int. Rev. Cytol.* 72 (1981) 49.
- Jeon, K. W.: Integration of bacterial endosymbionts in amoebae. *Int. Rev. Cytol. (suppl.)* 14 (1983) 29.
- Lee, R. E., P. Kugrens: Relationship between the flagellates and the ciliates. *Microbiol. Rev.* 56 (1992) 529.
- Martin, W., M. Müller: The hydrogen hypothesis for the first eukaryote. *Nature* 392 (1998) 37.
- Ragan, M. A., D. J. Chapman: *A biochemical phylogeny of the protists.* Academic Press, London 1978.
- Schlegel, M.: Protist evolution and phylogeny as discerned from small subunit ribosomal RNA sequence comparisons. *Europ. J. Protistol.* 27 (1991) 207.
- Sitte, P.: Symbiogenetic evolution of complex cells and complex plastids. *Europ. J. Protistol.* 29 (1993) 131.
- Sogin, M. L.: Early evolution and the origin of eukaryotes. *Current Opinion in Genetics and Development* 1 (1991) 457.
- Sogin, M. L., H. J. Elwood, J. H. Gunderson: Evolutionary diversity of eukaryotic small subunit rRNA genes. *Proc. Natl. Acad. Sci. USA* 83 (1986) 1383.
- Stoebe, U. G. Maier: One, two, three: nature's tool box for building plastids. *Protoplasma* 219 (2002) 123.
- Taylor, F. J. R.: On dinoflagellate evolution. *BioSystems* 13 (1980) 65.
- Taylor, F. J. R., D. J. Blackbourn, J. Blackbourn: The redwater ciliate *Mesodinium rubrum* and its incomplete symbionts — A review including new ultrastructural observations. *J. Fish. Res. Bd. Canada* 28 (1971) 391.

- Anderson, R.: Cytoplasmic origin and surface deposition of siliceous structures in *Sarcodina*. *Protoplasma* 181 (1994) 61.
- Bouck, G., H. Ngo: Cortical structure and function in euglenoids with references to trypanosomes, ciliates and dinoflagellates. *Int. Rev. Cytol.* 169 (1996) 268.
- Corliss, J. O.: Protozoan cysts and spores. In: *The Encyclopedia of Life Sciences*. Nature Publishing Group, London 2000.
- Corliss, J. O., S. C. Esser: Comments on the role of the cyst in the life cycle and survival of free living protozoa. *Trans. Amer. Microsc. Soc.* 93 (1974) 578.
- Grain, J.: The cytoskeleton in protists: nature, structure, and functions. *Int. Rev. Cytol.* 104 (1986) 153.
- Gutierrez, J. C., A. Marint Gonzales, T. Matsusaka: Towards a generalized model of encystment (cryptobiosis) in ciliates: a review and a hypothesis. *BioSystems* 24 (1990) 17.
- Leadbeater, B. S. C., R. Riding (eds): *Biomimicrization in lower plants and animals*. Clarendon Press, Oxford 1986.
- Melkonian, M., R. A. Andersen, E. Schnepf: *The cytoskeleton of flagellate and ciliate protists*. Springer Verlag, Wien 1991.
- Menzel, D. (ed): *Cytoskeleton of algae*. CRC Press, Boca Raton 1992.
- Morrill, L. C., A. R. Loeblich III: Ultrastructure of the dinoflagellate *Amphispma*. *Int. Rev. Cytol.* 82 (1983) 151.
- Mulisch, M.: Chitin in protistan organisms — Distribution, synthesis, and deposition. *Europ. J. Protistol.* 29 (1993) 1.
- Wetherbee, R., R. A. Anderson, J. D. Pickett Heaps (eds): *The protistan cell surface*. Springer Verlag, Wien 1994.
- Hovasse, R., J. P. Mignot, L. Joyon, J. Baudoin: Etude comparee des dispositifs servants à la fixation chez les protistes. *Ann. Biol.* 11 (1972) 1.
- Haacke Bell, R., R. Hohenberger Bregger, H. Plänner: Trichocysts of *Paramecium* — Secretory organelles in search of their function. *Europ. J. Protistol.* 25 (1990) 289.
- Harumoto, T., A. Miyake: Defensive function of extrusomes in ciliates. *Protozool. Monographs XX* (2003) X.
- Hausmann, K.: Extrusive organelles in protists. *Int. Rev. Cytol.* 52 (1978) 197.
- Hovasse, R.: Trichocystes, corps trichocystoïdes, cnidocystes et colloblastes. *Protoplasmatologia III F* (1965).
- Hovasse, R., J. P. Mignot: Trichocystes et organites analogues chez les protistes. *Ann. Biol.* 14 (1975) 397.
- Krillger, F.: Die Trichocysten der Ciliaten im Dunkelgebild. *Zoologica* 91 (1936) 1.
- Plattner, H., N. Klauke: Calcium in ciliated protozoa: sources, regulation, and calcium regulated cell functions. *Int. Rev. Cytol.* 201 (2001) 115.
- Rosati, G.: Epixenosomes: symbionts of the hypotrich ciliates *Euplotidium itoi*. *Symbiosis* 26 (1999) 1.
- Allen, R. D., Y. Naitoh: Osmoregulation and contractile vacuoles of protozoa. *Int. Rev. Cytol.* 215 (2002) 351.
- Dodge, J. D.: The ultrastructure of the dinoflagellate pusule: a unique osmoregulatory organelle. *Protoplasma* 75 (1972) 285.
- Hausmann, K., D. J. Patterson: Contractile vacuole complexes in algae. In: W. Wiessner, W. D. Robinson, R. C. Starr (eds): *Compartments in algal cells and their interaction*. Springer Verlag, Berlin 1984.
- Heuser, J., Q. Zhu, M. Clarke: Proton pumps populate the contractile vacuoles of *Dictyostelium amoebae*. *J. Cell Biol.* 121 (1993) 1311.
- Kitching, J. A.: Contractile vacuoles. *Biol. Rev.* 3 (1938) 403.
- Kitching, J. A.: Contractile vacuoles of protozoa. *Protoplasmatologia III D* (1956).
- Patterson, D. J.: Contractile vacuoles and associated structures: their organization and function. *Biol. Rev.* 55 (1980) 1.

- Blackman, J. J., L. Bannister: Apical organelles of Apicomplexa — Biology and isolation by subcellular fractionation. *Mol. Biochem. Parasitol.* 117 (2001) 11.
- Dubremetz, J. F., N. Garcia Reguet, V. Conseil, M. N. Fourmaux: Apical organelles and host cell invasion by Apicomplexa. *Int. J. Parasitol.* 28 (1998) 1007.
- Fenchel, P., J. Finlay: The structure and function of Mtiller vesicles in loxodid ciliates. *J. Protozool.* 33 (1986) 69.
- Gleeson, M.: The plastid in Apicomplexa: What use is it? *Int. J. Parasitol.* 30 (2000) 1053.
- Hackstein, J. H. P., A. Akhmanova, F. Voncken, A. van Hoek, T. von Alen, B. Boxma, S. Y. Moon van der Staay, G. van der Staay, J. Leunissen, M. Huynen, J. Rosenberg, M. Veenhuis: Hydrogenosomes: convergent adaptations of mitochondria to anaerobic environments. *Zoology* 104 (2001) 290.
- Hannert, V., P. A. M. Michels: Structure, function and biogenesis of glycosomes in Kinetoplastida. *J. Bioenerg. Biomembr.* 26 (1994) 205.
- Lynn, D. H., S. Frombach, M. S. Ewing, M. Kocan: The organelle of Lieberkithn as a synapomorphy for the Ophryoglenina (Ciliophora: Hymenostomatida). *Trans. Am. Microsc. Soc.* 110 (1991) 1.
- Marechal, E., M. F. Cesbron Delauw: The apico plast: a new member of the plastid family. *TPS* 6 (2001) 200.
- Morris, J., M. E. Drew, M. M. Klingbeil, S. A. Motyka, T. Saxowsky, Z. Wang, P. T. Englund: Replication of kinetoplast DNA: an update for the new millenium. *Int. J. Parasitol.* 31 (2001) 453.
- Mtiller, M.: The hydrogenosome. *J. Gen. Microbiol.* 139 (1993) 2879.
- Mtiller, M.: Core carbohydrate metabolism of extracellular amitochondriate parasitic protists. In: Marr, J., T. Nilsen, R. Komuniecki (eds): *Molecular medical parasitology*. Academic Press, London 2002.
- Opperdoes, F. R., P. A. M. Michels: The glycosomes of the Kinetoplastida. *Biochimie* 75 (1993) 231.
- Pitelka, D. R.: *Electron microscopic structure of protozoa*. Pergamon, Oxford 1963.
- Plattner, H. (ed): *Membrane traffic in protozoa*, part I + II. JAI Press, Greenwich 1993.
- Rybicka, K. K.: Glycosomes — The organelles of glycogen metabolism. *Tiss. & Cell* 28 (1996) 253.
- Stuart, K., J. E. Feagin: Mitochondrial DNA of kinetoplastids. *Int. Rev. Cytol.* 148 (1992) 65.
- Allen, R. D., N. Kamiya (eds): *Primitive motile systems in cell biology*. Academic Press, London 1964.
- Amos, W., J. G. Duckett (eds): *Prokaryotic and eukaryotic flagella*. Cambridge University Press, Cambridge 1982.
- Bloodgood, R. A. (ed): *Ciliary and flagellar membranes*. Plenum Press, New York 1990.
- Cachon, J., M. Cachon: Movement by non actin filament mechanisms. *BioSystems* 14 (1981) 313.
- Fukui, Y.: Toward a new concept of cell motility: cytoskeletal dynamics in amoeboid movement and cell division. *Int. Rev. Cytol.* 144 (1993) 85.
- Grebecki, A.: Membrane and cytoskeleton flow in motile cells with emphasis on the contribution of free living amoebae. *Int. Rev. Cytol.* 148 (1994) 37.
- Komnick, P., W. Stockem, K. E. Wohlfarth Bottermann: Cell motility: mechanisms in protoplasmic streaming and amoeboid movement. *Int. Rev. Cytol.* (1973) 169.
- Machemer, H.: Electromotor coupling in cilia. In: Ltittgau, H. S. (ed): *Membrane control of cellular activity*. *Fortschr. Zool.* 33 (1986) 205.
- Machemer, H.: Motor control of cilia. In: Görtz, H. D. (ed): *Paramecium*. Springer Verlag, Berlin 1988.
- Machemer, H.: Cilia in cell motility: membrane controlled rotary engines. *Zool. Sci.* 7 (1990) 23.
- Machemer, H., J. de Peyer: Swimming sensory cells: electrical membrane parameters, receptor properties and motor control in ciliated

- protozoa. Verh. Dtsch. Zool. Ges. 1977 (1977) 86.
- Melkonian, M (ed): Algal cell motility. Current Phycology, vol. III. Chapman and Hall, New York 1992.
- Parducz, J.: Ciliary movement and coordination in ciliates. *Int. Rev. Cytol.* 21 (1967) 91.
- Preston, J. M., C. A. King: Strategies for cell substratum dependent motility among protozoa. *Acta Protozool.* 35 (1996) 3.
- Preston, J. M., C. A. King, J. S. Hyams: The cytoskeleton and cell motility. Chapman and Hall, New York 1990.
- Sleigh, M. A.: Cilia and flagella. Academic Press, London 1974.
- Stockem, W., W. Klopecka: Ameboid movement and related phenomena. *Int. Rev. Cytol.* 112 (1988) 137.
- Stockem, W., K. Brix: Analysis of microfilament organization and contractile activities in *Physarum*. *Int. Rev. Cytol.* 149 (1994) 145.
- Taylor, D. L., J. S. Condeelis: Cytoplasmic structure and contractility in amoeboid cells. *Int. Rev. Cytol.* 56 (1979) 57.
- Allen, R. D.: Membranes of ciliates: ultra structure, biochemistry and fusion. In: Poste, G., L. Nicolson (eds): Membrane fusion. Elsevier Science Publishers, Amsterdam 1978.
- Allen, R. D.: *Paramecium* phagosome membrane: from oral region to cytoproct and back again. *J. Protozool.* 31 (1984) 1.
- Allen, R. D., A. K. Fok: Membrane trafficking and processing in *Paramecium*. *Int. Rev. Cytol.* 198 (2000) 277.
- Chapman Andresen, C: Studies on pinocytosis in amoebae. *C. R. Lab. Carlsberg* 33 (1962) 73.
- Fok, A. K., R. D. Allen: The phagosome lysosome membrane system and its regulation in *Paramecium*. *Int. Rev. Cytol.* 123 (1990) 61.
- Hausmann, K.: Food acquisition, food ingestion and food digestion by protists. *Jpn. J. Protozool.* 35 (2002) 85.
- Kitching, J. A.: Food vacuoles. *Protoplasma* 109 (1965).
- Mast, S. O.: The food vacuole in *Paramecium*. *Biol. Bull.* 92 (1947) 31.
- Nisbet, J.: Nutrition and feeding strategies in protozoa. Croom Helm, London 1984.
- Radek, R., K. Hausmann: Endocytosis, digestion, and defecation in flagellates. *Acta Protozoologica* 33 (1994) 127.
- Schnepf, E., M. Elbrachter: Nutritional strategies in dinoflagellates — A review with emphasis on cell biological aspects. *Europ. J. Protistol.* 28 (1992) 3.
- Sikora, J.: Cytoplasmic streaming in *Paramecium*. *Protoplasma* 109 (1981) 57.
- Stockem, W., E. Wohlfarth Bottermann: Pinocytosis (endocytosis). In: Lima de Faria, A. (ed): Handbook of molecular cytology. Elsevier Science Publishers, Amsterdam 1969.
- Verni, F., P. Gualtieri: Feeding behaviour in ciliated protists. *Micron* 28 (1997) 587.
- Adl, S. M., J. D. Berger: Commitment to division in ciliate cell cycles. *J. Euk. Microbiol.* 43 (1996) 77.
- Aufderheide, K. J., J. Frankel, N. E. Williams: Formation and positioning of surface related structures in protozoa. *Microbiol. Rev.* 44 (1980) 252.
- Beisson, J., M. Jerka Dziadosz: Polarities of the centriolar structure: morphogenetic consequences. *Biol. Cell* 91 (1999) 367.
- Berger, J. D.: Riding the ciliate cell cycle — A thirty five year prospective. *J. Euk. Microbiol.* 48 (2001) 505.
- Frankel, J. (ed): Pattern formation: ciliate studies and models. Oxford University Press, New York 1989.
- Fulton, C: Cell differentiation in *Naegleria gruberi*. *Ann. Rev. Microbiol.* 31 (1977) 597.
- Grimes, G. W., K. J. Aufderheide: Cellular aspects of pattern formation: the problem of assembly. Monographs in Developmental Biology, vol. 22. Karger, Basel 1991.
- Grimstone, A. V.: Fine structure and morphogenesis in protozoa. *Biol. Rev.* 36 (1961) 97.

- Jeon, S. W., J. F. Danielli: Microsurgical studies with large free living amebas. *Int. Rev. Cytol.* 56 (1979) 57.
- Jerka Dziadosz, M.: Control of pattern formation in ciliated protozoa. In: Nover L., F. Lynen, K. Mothes (eds): *Cell compartmentation and metabolic channeling*, Gustav Fischer Verlag, Jena 1980.
- Lwoff, A.: *Problems of morphogenesis in ciliates*. Wiley, New York 1950.
- Menzel, D.: The role of the cytoskeleton in polarity and morphogenesis of algal cells. *Curr. Opin. Cell Biol.* 8 (1996) 38.
- Nanney, D. L.: *Experimental ciliatology: an introduction to genetic and developmental analysis in ciliates*. Wiley, New York 1980.
- Ameisen, J.: The evolutionary origin and role of programmed cell death in single celled organisms: a new view of executioners, mitochondria, host pathogen interactions, and the role of death in the process of natural selection. In: Lockshin, R. A., Z. Zakeri, J. L. Tilly (eds): *When cells die*. Wiley Liss, New York 1998.
- Beale, G. H.: *The genetics of Paramecium aurelia*. Monographs of experimental biology. Cambridge University Press, Cambridge 1954.
- Belar, K.: *Der Formwechsel der Protistenkerne*. Gustav Fischer Verlag, Jena 1926.
- Bell, G.: *Sex and death in protozoa. The history of an obsession*. Cambridge University Press, Cambridge 1989.
- Dini, F., J. O. Corliss: Protozoan sexuality. In: *The Encyclopedia of Life Sciences*. Nature Publishing Group, London 2001.
- Dini, E., D. Nyberg: Sex in ciliates. *Advances in Microbial Ecology* 13 (1993) 85.
- Heywood, P., P. T. Magee: Meiosis in protists. *Bact. Rev.* 40 (1976) 190.
- Loidl, P., A. Eberharter: Nuclear matrix and the cell cycle. *Int. Rev. Cytol.* 162 (1995) 377.
- Luporini, P., A. Vallesi, C. Miceli, R. A. Bradshaw: Chemical signaling in ciliates. *J. Euk. Microbiol.* 42 (1995) 208.
- Luporini, P., A. Vallesi, C. Miceli, R. A. Bradshaw: Ciliate pheromones as early growth factors and cytokines. *Ann. NY Acad. Sci.* 712 (1994) 195.
- Miyake, A.: Cell communication, cell union, and initiation of meiosis in ciliate conjugation. *Curr. Top. Dev. Biol.* 12 (1978) 37.
- Ng, S. E.: Developmental heterochrony in ciliated protozoa: overlap of asexual and sexual cycles during conjugation. *Biol. Rev.* 65 (1990) 19.
- Raikov, I.: The protozoan nucleus — Morphology and evolution. Springer Verlag, Wien 1982.
- Raikov, I.: The diversity of forms of mitosis in Protozoa: a comparative review. *Europ. J. Protistol.* 30 (1994) 253.
- Raikov, I. B.: Meiosis in protozoa: recent advances and persisting problems. *Europ. J. Protistol.* 31 (1995): 1.
- Raikov, I.: Structure and genetic organization of the polyploid macronucleus of ciliates: a comparative review. *Acta Protozoologica* 34 (1995) 151.
- Smith Sonneborn, J.: Genetics and aging in protozoa. *Int. Rev. Cytol.* 73 (1981) 319.
- Takagi, Y.: Clonal life cycle of *Paramecium* in the context of evolutionally acquired mortality. *Progr. Mol. Subc. Biology* 24 (1999) 81.
- Tarin, J. J., A. Cano (eds): *Fertilization in protozoa and metazoan animals — Cellular and molecular aspects*. Springer Verlag, Berlin 2000.
- Weiss, M. S., D. H. Anderson, S. Raffioni, R. A. Bradshaw, C. Ortenzi, P. Luporini, D. Eisenberg: A cooperative model for receptor recognition and cell adhesion: evidence from the molecular packing in the 1.6 Å crystal structure of the pheromone Er 1 from the ciliated protozoan *Euplotes raikovi*. *Proc. Natl. Acad. Sci. USA* 92 (1995) 10172.
- Carlile, M. J.: Primitive sensory and communication systems. The taxes and tropisms of micro organisms and cells. Academic Press, London 1975.
- Colombetti, G.: New trends in photobiology: photomotile responses in ciliated protozoa. *J. Photochem. Photobiol.* 15 (1990) 243.

- Dodge, J. D.: A review of the fine structure of algal eyespots. *Brit. phycol. J.* 4 (1969) 199.
- Fenchel, P., J. Finlay: Oxygen toxicity, respiration and behavioural responses to oxygen in free living anaerobic ciliates. *J. Gen. Microbiol.* 136 (1990) 1953.
- Haupt, W.: Phototaxis in plants. *Int. Rev. Cytol.* 19 (1966) 267.
- Houten, J. van.: Chemosensory transduction in eukaryotic microorganisms. *Ann. Rev. Physiol.* 54 (1992) 639.
- Hegemann, P.: Vision in microalgae. *Planta* 203 (1997) 265.
- Hegemann, P., M. Fuhrmann, S. Kateriya: Algal sensory photoreceptors. *J. Phycol.* 37 (2001) 668.
- Houten, J. van.: Chemosensory transduction in eukaryotic microorganisms. *Ann. Rev. Physiol.* 54 (1992) 639.
- Jennings, H. S.: Behaviour of lower organisms. Columbia University Press, New York 1906.
- Korohoda, W., M. Mycielska, E. Janda, Z. Madeja: Immediate and long term galvanotactic responses of *Amoeba proteus* to dc electric fields. *Cell Motil. Cytoskel.* 45 (2000) 10.
- Kreimer, G.: Cell biology of phototaxis in flagellate algae. *Int. Rev. Cytol.* 148 (1994) 229.
- Kung, C, Y. Saimi: The physiological basis of taxes in *Paramecium*. *Ann. Rev. Physiol.* 44 (1982) 519.
- Kusch, J.: Induction of defensive morphological changes in ciliates. *Oecologia* 94 (1993) 571.
- Machemer, H.: Galvanotaxis: Grundlagen der elektromechanischen Kopplung und Orientierung bei *Paramecium*. In: Zupanc, G. H. K. (Hrsg): *Praktische Verhaltensbiologie*. Paul Parey, Berlin 1988.
- Machemer, H.: Unicellular responses to gravity transitions. *Space Forum* 3 (1998) 3.
- Machemer, H.: Cellular behaviour modulated by ions: electrophysiological implications. *J. Protozool.* 36 (1989) 563.
- Machemer, H.: The swimming cell and its world: structures and mechanisms of orientation in protists. *Europ. J. Protistol* 37 (2001) 3.
- Machemer, H., R. Braucker: Gravireception and gravireponse in ciliates. *Acta Protozool.* 31 (1992) 185.
- Machemer, H., J. W. Deitmer: From structure to behaviour: *Stylonychia* as a model system for cellular physiology. *Progr. Protistol.* 2 (1987) 213.
- Machemer, H., J. de Peyer: Swimming sensory cells: electrical membrane parameters, receptor properties and motor control in ciliated protozoa. *Verh. Dtsch. Zool. Ges.* 1977 (1977) 86.
- Melkonian, M., H. Robenek: The eyespot apparatus of flagellated green algae — A critical review. *Progr. Phycol. Res.* 3 (1984) 193.
- Nakaoka, Y, T. Kurotani, H. Itoh: Ionic mechanism of thermoreception in *Paramecium*. *J. Exp. Biol.* 127 (1987) 95.
- Nultsch, W., D. P. Hader: Photomovement of motile microorganisms. *Photochem. Photobiol.* 29 (1979) 423.
- Song, P. S., K. L. Poff: Photomovement. In: Smith, C. (ed): *The science of photobiology*, 2nd ed. Plenum, New York 1989.
- Song, P. S., I. H. Kim, J. S. Rhee, J. W. Huh, S. Florell, B. Faure, K. W. Lee, T. Kahsai, N. Tamai, T. Yamazaki, I. Yamazaki: Photo-reception and photomovements in *Stentor coeruleus*. In: Lenci, E, F. Ghetti, G. Colombetti, D. P. Hader, P. S. Song (eds): *Biophysics of photoreceptors and photomovements in microorganisms*. Plenum Press, New York 1991.

Protozoa

- Arndt, H.: A critical review of the importance of rhizopods (naked and testate amoebae) and actinopods (heliozoa) in lake plankton. *Marine Microbial Food Webs* 7 (1993) 3.
- Baden, D. G.: Marine food borne dinoflagellate toxins. *Int. Rev. Cytol.* 82 (1983) 99.
- Boney, A. D.: *Phytoplankton*, 2nd ed. Arnold, New York 1989.
- Capriulo, G.M. (ed): *Ecology of marine protozoa*. Oxford University Press, New York (1990).
- Cairns, J.: Freshwater protozoan communities. In: Bull, A. T., J. H. Slater (eds): *Microbial*

- interactions and communities, vol. 1. Academic Press, London 1982.
- Cosper, E. M., V. M. Bricelj, E. J. Carpenter (eds): Novel phytoplankton blooms, causes and impacts of recurrent brown tides and other unusual blooms. Springer Verlag, Berlin 1989.
- Curds, C. R.: The ecology and role of protozoa in aerobic sewage treatment processes. *Ann. Rev. Microbiol.* 36 (1982) 27.
- Curds, C. R.: Protozoa in the water industry. Cambridge University Press, Cambridge 1992.
- Fenchel, P.: The ecology of marine microbenthos, I IV. *Ophelia* 4 (1967) 121; 5 (1968) 73; 5 (1968) 123; 6 (1969) 1.
- Fenchel, P.: Ecology of protozoa: the biology of free living phagotrophic protists. Springer Verlag, Berlin 1987.
- Fenchel, P., J. Finlay: Ecology and evolution in anoxic worlds. In: May, R. M., P. Harvey (eds): Oxford series in ecology and evolution. Oxford University Press, Oxford 1995.
- Finlay, B. J.: Physiological ecology of free living protozoa. *Adv. Microb. Ecol.* 11 (1990) 1.
- Fukuyo, Y., H. Takano, M. Chihara, K. Matsuoka: Red tide organisms in Japan. Uchida Rokakuho, Tokyo 1990.
- Granéli, E., B. Sundstrom, D. M. Anderson: Toxic marine phytoplankton. Elsevier Science Publishers, Amsterdam 1990.
- Hallegraeff, G. M.: Aquaculturists' guide to harmful Australian microalgae. SCIRO, Hobart 1991.
- Laybourn Parry, J.: Protozoan plankton ecology. Chapman and Hall, London 1992.
- Lloyd, D., G. H. Coombs, T. A. Paget (eds): Biochemistry and molecular biology of anaerobic protozoa. Harwood Academic Publishers, London 1988.
- Nilsson, J. R.: *Tetrahymena* in cytotoxicology: with special reference to effects of heavy metals and selected drugs. *Europ. J. Protistol.* 25 (1989) 2.
- Sieburth, J. McN.: Sea microbes. Oxford University, New York 1979.
- Smayda, T. J., Y. Shimizu (eds): Toxic phytoplankton blooms in the sea. Elsevier, Amsterdam 1993.
- Yasumoto, T., Y. Oshima, Y. Fukuyo (eds): Harmful and toxic algal blooms. IOC UNESCO, Paris 1996.

Protozoa

- Aikawa, M., C. R. Sterling: Intracellular parasitic protozoa. Academic Press, London 1974.
- Baker, J. R.: Parasitic protozoa. Hutchinson, London 1969.
- Baker, J. R.: Biology of parasitic protozoa. Arnold, London 1982.
- Baker, J., R. Muller, D. Rollinson (eds): Opportunistic protozoa in humans. Academic Press, London 1998.
- Bush, A. O., J. C. Fernandez, G. W. Esch, J. R. Seed: Parasitism — The diversity and ecology of animal parasites. Cambridge University Press, Cambridge 2001.
- Dollet, M.: Plant diseases caused by flagellate protozoa (*Phytomonas*). *Ann. Rev. Phyto. pathol.* 22 (1984) 115.
- Gardiner, J. H., R. Fayer, J. P. Dubey: An atlas of protozoan parasites and animal tissues. US Dept. of Agriculture, Agriculture Handbook No. 651, Washington 1988.
- Honigberg, S. M. (ed): Trichomonads parasitic in humans. Springer Verlag, Heidelberg 1990.
- Kreier, J. P.: Parasitic protozoa, 10 volumes, 2nd ed. Academic Press, London 1991 1995.
- Kreier, J. P., J. R. Baker: Parasitic protozoa. Allen & Unwin, Winchester 1987.
- Martinez, A. J., G. S. Visvesvara: Free living, amphizoic and opportunistic amebas. *Brain Pathol.* 7 (1997) 583.
- Mehlhora, H. (ed): Encyclopedic reference of parasitology, 2nd ed. Springer Verlag, Berlin 2001 (first published as «Parasitology in focus», 1988).
- Lorn, J., I. Dykova: Protozoan parasites of fishes. Elsevier Science Publishers, Amsterdam 1992.
- Rondanelli, E. G., G. Carosi, G. Filice: Human pathogenic protozoa. Piccin Padova 1987.
- Rondanelli, E. G., M. Scaglia: Atlas of human protozoa. Masson, Milano 1993.
- Breznak, J. A.: Intestinal microbiota of termites and other xylophagous insects. *Ann. Rev. Microbiol.* 36 (1982) 323.

- Finlay, J., Fenchel: Methanogens and other bacteria as symbionts of free living anaerobic ciliates. *Symbiosis* 14 (1992) 375.
- Görtz, H. D.: Endonuclear symbionts in ciliates. *Int. Rev. Cytol.* 14 (suppl.) (1983) 145.
- Görtz, H. D., T. Brigge: Intracellular bacteria in protozoa. *Naturwiss.* 85 (1998) 359.
- Görtz, H. D., H. W. Kuhlmann, M. Möllenbeck, A. Tiedtke, J. Kusch, H. J. Schmidt, A. Miyake: Intra- and intercellular communication systems in ciliates. *Naturwiss.* 86 (1999) 422.
- Heckmann, K.: Endosymbionts of *Euplotes*. *Int. Rev. Cytol.* 14 (suppl.) (1983) I'll.
- Honigberg, M.: Protozoa associated with termites and their role in digestion. In: Krishna, K., F. M. Weesner (eds): *Termites*, vol. II. Academic Press, London 1970.
- Jeon, K. W.: The large, free living amoebae: wonderful cells for biological studies. *J. Euk. Microbiol.* 42 (1995) 1.
- Lee, J. J.: Perspective on algal endosymbionts in larger Foraminifera. *Int. Rev. Cytol.* 14 (suppl.) (1983) 49.
- Lee, J. J.: «Living sands»: larger Foraminifera and their endosymbiotic algae. *Symbiosis* 25 (1998) 71.
- Ogimoto, K., S. Imai: Atlas of rumen microbiology. Japan Sci. Soc, Tokyo 1981.
- Ossipov, D., S. A. Karpov, A. V. Smirnov, M. S. Rautian: Peculiarities of the symbiotic systems of protists with diverse patterns of cellular organisation. *Acta Protozool.* 36 (1997) 3.
- Preer, J. R., J. L. B. Preer, A. Jurand: Kappa and other endosymbionts in *Paramecium aurelia*. *Bact. Rev.* 38 (1974) 113.
- Reisser, W. (ed): Algae and symbioses: plants, animals, fungi, viruses, interactions explored. Biopress, Bristol 1992.
- Reisser, W.: Enigmatic chlorophycean algae forming symbiotic associations with ciliates. In: Seckbach, J. (ed): *Evolutionary pathways and enigmatic algae: Cyanidium caldarium* (Rhodophyta) and related cells. Kluwer Academic Publishers, Dordrecht 1994.
- Reisser, W., W. Wiessner: Autotrophic eucaryotic freshwater symbionts. *Encyclop. Plant Physiol.* (New Series) Springer Verlag, Berlin 1984.
- Soldo, B.: The biology of the xenosome, an intracellular symbiont. *Int. Rev. Cytol.* 14 (suppl.) (1983) 79.
- Souza, W. de, M. C. Machado Motta: Endosymbiosis in protozoa of the Trypanosomatidae family. *FEMS Microbiol. Letters* 173 (1999) 1.
- Taylor, D. L.: Chloroplasts as symbiotic organelles. *Int. Rev. Cytol.* 27 (1970) 29.
- Williams, A. G., G. S. Coleman: The rumen protozoa. Springer Verlag, Berlin 1992.
- Canter Lund, H., J. W. G. Lund: Freshwater algae — Their microscopic world explored. Biopress, Bristol 1995.
- Carey, P. G.: Marine interstitial ciliates — An illustrated key. Chapman & Hall, London 1992.
- Cash, J., G. H. Wailes: The British freshwater rhizopoda and heliozoa, vol. 1 V. Roy. Soc, London 1905 1921.
- Dillard, G. E.: Common freshwater algae of the United States — An illustrated key to the genera (excluding the diatoms). Gebrüder Borntraeger Verlagbuchhandlung, Berlin 1999.
- Dodge, J. D.: Atlas of dinoflagellates. Ferrand Press, London 1985.
- Ettl, H., J. Gerloff, H. Heynig, D. Mollenhauer (Hrsg): Süßwasserflora von Mitteleuropa, 20 Bände. Gustav Fischer Verlag, Stuttgart 1978 — im Druck.
- Foissner, W., H. Berger, J. Schaumburg: Identification and ecology of limnetic plankton ciliates. Informationsberichte des Bayerischen Landesamtes für Wasserwirtschaft, München 1999.
- Foissner, W., H. Blatterer, H. Berger und F. Kohmann: Taxonomische und ökologische Revision der Ciliaten des Saprobien-systems. Band 1: Cytrophorida, Oligotrichida, Hypotrichida, Colpodea.
Band 2: Peritrichia, Heterotrichida, Odontostomatida.
Band 3: Hymenostomata, Prostomatida, Nassulida.

- Band 4: Gymnostomata, Suctoria, *Loxodes*. Informationsberichte des Bayerischen Landesamtes für Wasserwirtschaft, München 1991—1995.
- Hausmann, K., D. J. Patterson: Taschenatlas der Einzeller. Protisten. Arten und mikroskopische Anatomie, 2. Aufl. Franckh'sche Verlagshandlung, Stuttgart 1987.
- Jahn, T. L., E. C. Bovee, F. F. Jahn: How to know the Protozoa, 2nd. ed. WCB / McGraw Hill, Boston 1978.
- Kahl, A.: Urtiere, oder Protozoa. I. Wimpertiere oder Ciliata (Infusoria). In: Dahl, F. (Hrsg): Die Tierwelt Deutschlands. Gustav Fischer Verlag, Jena 1930 1935.
- Lee, J. J., G. F. Leedale, P. C. Bradbury (eds): Illustrated guide to the protozoa, vol. I+II 2nd ed., Allen Press, Lawrence 2000.
- Lepši, I.: Fauna Republicii Populare Romine, Protozoa, Vol. I, Rhizopoda, Fasc. 2, Euamoebidea. Editura Academiei Republicii Populare Romine, 1960.
- Murray, J. W.: An atlas of British recent foraminiferids. Heinemann, London 1971.
- Ogden, C. G., R. H. Hedley: An atlas of freshwater testate amoebae. Oxford University, Oxford 1980
- Page, F. C.: An illustrated key to freshwater and soil amoebae with notes on cultivation and ecology. Freshwater Biological Association, Sci. Publ. No. 34. Wilson, Kendal 1976.
- Page, F. C.: Marine Gymnamoebae. Institute of Terrestrial Ecology, printed by Lavenham Press, Lavenham 1983.
- Page F. C.: A new key to freshwater and soil gymnamoebae with instructions for culture. Freshwater Biological Association, Ambleside 1988.
- Patterson, D.: Free living freshwater protozoa. A color guide. CRC Press, Boca Raton 1992.
- Streble, H., D. Krauter: Das Leben im Wassertropfen. Mikroflora und Mikrofauna des Süßwassers, 9. Aufl. Franckh'sche Verlagshandlung, Stuttgart 2002.
- Tomas, C.R. (ed): Identifying marine phytoplankton. Academic Press, London 1997.
- Vors, N.: Heterotrophic amoebae, flagellates and heliozoa from the Tvarminne Area, Gulf of Finland, in 1988 1990. *Ophelia* 36 (1992) 1.
- Zhukov, B. F.: Atlas of freshwater heterotrophic flagellates (biology, ecology, taxonomy) (in Russian). Russian Academy of Sciences, Institute of the Biology of Inland Waters, Borok 1993.
- Zhukov, B. F., S. A. Karpov: Freshwater choanoflagellates (in Russian). Nauka, Leningrad 1985.
- Finlay, J., A. Rogerson, A. J. Cowling: A beginner's guide to the collection, isolation, cultivation and identification of freshwater protozoa. CCAP, Ambleside 1988.
- Jensen, J. B. (ed): In vitro cultivation of protozoan parasites. CRC Press, Boca Raton 1983.
- Lee, J. J., A. T. Soldo: Protocols in protozoology. Society of Protozoologists, Allen Press, Lawrence 1992.
- Anderson, O. R., M. Druger (eds): Explore the world using protozoa. National Science Teachers Associations, Arlington 1997.
- Rottger, R. (Hrsg): Praktikum der Protozoologie. Gustav Fischer Verlag, Stuttgart 1995.

(Protozoa) -

(

) . 1993. . 1993.

. T.I. . 1972.

. 1978.

. ()

. 1981.

. 1951.

. 1976. 2.

. 1977. .

. 1968.

. 1977.

. 1990.

. 2001.

2005.

. 1994. 1, 2.

I:

. 1994.

II:

. 1998.

Myxomycota, .1.

Myxomycetes. . 1993.

Nas

sellaria . 1981.

.1. : . 2000.

.2. : . 2007.

. 1978.

(Acantharicia, Protozoa)

. 1981.

. 1984.

. 1999.

. 1968.

. 1984.

. 1984.

. 1991.

. 1966.

. 1982.

- Acanthamoeba* 207, 208, **261**, 357, 358, **434**, 443
 — *castellanii* 208, 450
 — *culbertsoni* 208
 — *palestinensis* 450
 — *polyphaga* 208
Acantharea 38, 53, 55, 243, **245**, 309
Acantharia 56, 59
Acanthocolla 247
Acanthocystidae **244**
Acanthocystis 252, **271**
 — *pantopodeoides* **434**
 — *turfacea* 429
Acanthoecopsis apoda **235**
Acantholithium 247
Acanthometra 247
Acarpomylax 55, 205, 208, 211, 213
Acetabularia **198**
 — *acetabulum* 198
Achlya 116, 117
Acineta **164**
 — *tuberosa* 367
Acinetopsis **165**
Aconchulina 38, 211, 213, **214**, 216, 318
Aconchulinida 213
Aconoidasida 132, 139
Aconoidina 139
Acrasea 55, 56, 61, 88, **89**, 211, 356
Acrasida 56
Acrasis 89
 — *rosea* **89**
Acrita 10
Actinobolina radians **434**
Actinomonas 251, **315**
Actinophryida **244**, 250
Actinophrys 18, **38**, **40**, **44**, 250, 257, 314, 337,
 338, 341, 342, 344
 — *sol* **39**, **243**, **250**, **259**, **325**, 349, **350**, 357, **459**
Actinopoda 56, 57, 58, 242, **243**, 303
Actinopodea 55
Actinosphaerium 250, **261**, 336
Actinosporea 55, 56, 239
Acytostelium 213
Adeleida 135
- Adineta* 278
Aedes 139
Aeromonas salmonicida 450
Agamococcida 135
Aggregata 138
Albugo 117
Alexandrium 123, 125
 — *catenella* 123
 — *tamarensis* 123, 370
Allogromia 38, 40, 190
Allogromiida 185, 186, 188
Allogromiidae 456
Alveolata 57, 58, 61, 117, 118, 119, 124, 125,
 126, 145, 177, 179, 192
Amblyospora 343
Amblyostoma 224
Amoeba 18, 37, 40, 44, 208
 — *proteus* 11, 37, 39, 207, 260, 299, 300, 313,
 337, 341, 412, 425, 429, 450
Amoebae 456
Amoebidium 234
 — *parasiticum* 234
Amoebomastigota 56
Amoebophrya 123
Amoebozoa 57, 58, 61, 205, 207, 209
Amphiacantha 224
Amphiacon 247
Amphidinium 420
 — *cryophilum* 312
 — *poecilochroum* 124
Amphileptus 161
Amphipleura pellucida 106
Amphipoda 439
Anaeromonada 58
Anaitides mucosa 440
Animalcula 8, 15, 53
Animalcula Infusoria 9
Animalia 8, 10, 215, 232
Animalia Microscopica 9
Anisolpidium 115
Anisonema 75, 78
Anopheles 139, 140
 — *gambia* 458

- Anoplophrya* 176
Anthophysa 103, **103**
Anurofeca 234
— *richardsi* 234
Apicomplexa 24, 33, **50**, 54, 55, 57, 59, 61, 117, **118**, **124**, 126, **127**, **128**, 129, **130** **132**, **136**, **140**, 192, 218, 272, 311, 313, 336, 338, 341, 347, **348**, 349, 356, 364, 368, 390, 393, 444
Apiosoma amoeba **261**
Apostomatia 154, 171, 368
Apusozoa 58
Arabidopsis 395
Arachnoidiscus **105**
Arachnula 214, 341
Arcella 18, 208, 341, 343, 349
— *vulgaris* **207**, 365
Arcellinida 59
Archaea 66
Archaeascomycota 215, 224, 227
Archaezoa 9
Archamoeba 58, **209**, **210**
Archamoebaea 57
Archezoa 10, 11, 58
Archigregarinida 134
Armophorida 158
Arthracanthida 247
Ascetospora 54, 57, 117, 179, 254
Ascomycetes 200
Ascomycota **48**, 215, 216, 224, **225** **229**
Ascospionia 198
Askenasia volvox **434**
Aspidisca 159
— *cicada* **434**
Astasia 78
— *longa* **303**
Asterias amurensis 444
Asterionella formosa **105**
Astomatia 154, 176, 368
Astracantha 249
Astrorhiza limicola **190**
Athalamea 57, 185
Aulacantha 249
Aulacomonas submarina **64**
Auloceros elegans **249**
Aurantiactinomyxon 343
AveHa 156
Axostylaria 58
Axostylata 57
Babesia 144
— *bigemina* **143**, 144
— *bovis* 144
— *divergens* 144
— *microti* 144
Bacillaria 108
Bacillariophyceae **50**, 57, 104, **105**, **106**
Bacillariophyta 57
Bacteria 456
Balantidium 162
Barbulanympha 75, 338
Basidiomycota **48**, 215, 216, 229
Bicoeca **113**
Bicoecida 56
Bicosoeca **113**, **315**
Bicosoecida 433
Bicosoecidea **113**, 456
Biddulphia 108
— *aurita* **105**
— *sinensis* 457
Bilateria 215
Biliphyta **31**, **48**, 190, **191**, **193**
Biomyxa 185
Blaps mortisaga **133**
Blastocrithidia triatomae **81**
Blastodinium 122, 123
Blepharisma **157**, 272, 273, 353, 357, **358**, 393, 411
— *americanum* **430**
— *intermedium* 352
— *japonicum* 272, 352, 353
Bodo 18, **78**, **80**, 82, **315**
— *saltans* 82, **315**
Bodonea **78**, 80, **80**, 81, 456
Bordnamonas 76
Brachonella spiralis **434**
Bracteacoccus **199**
Bresslaua 167
Bresslauides australis **168**
Bursaria 167, 343, 357
— *truncatella* 17, 167, **168**, **430**
Caenomorpha 422
— *lauterborni* **434**
— *levanderi* **435**
Caenorhabditis 395
Cafeteria 113, **315**
— *roenbergensis* **315**
Calcarea 215

- Calonympha* 73
 Calonymphidae 73
Camptonema 250
Candida 215
 — *albicans* 227
Carchesium 18, **173**, 260
Carpediemonas 67
Caulerpa 198
Caviomonas 69
Cavostelium 211
 Centrales 108
 Centrohelida **244**, 251, **252**
Centropyxis **434**
Cepedia 100
Ceratiomyxa 211
Ceratium 121, 123
 — *cornutum* **120**
 — *hirudinella* 17
 — *macroceros* **120**
 — *ripos* **120**
Ceratocorys horrida **120**
Cercobodo **183**
 — *fraco* **183**
 — *norrvicensis* **183**
 — *pyriformis* **183**
 — *varians* **183**
Cercomonas **183**
 Cercozoa 38, 58, 65, 112, 179, **181**, **182**, 183,
 205, 213, 243
Chaenea sapropelica **434**
Chaetoceros castracanei **105**
 — *convolutus* 107
 Chaetognatha 456
 Chaetophorales 201
Chaetosphaeridium 204
Challegeron wyvillei **249**
C/zaos 208, 336
 — *carolinense* 207, 455
 — *c/iaos* 299, 429
 — *illinoisense* 455
 Charales 203
 Charophyceae 57, 196
Chattonella **112**, 113
 — *antiqua* 112
 — *marina* 112
 Chaunacanthida 247
Chilodonella **163**, 345
 — *cuculus* 346
Chilomastix 67
 — *gallinarum* 67
 — *mesnili* 67
Chilomonas **35**, **42**, 96, **287**, **308**, 404
 — *Paramecium* **276**
Chitonella 163
Chlamydia 450
Chlamydonon 163, 414
Chlamydomonas 18, **199**, **202**, 203, 284, 344,
 347, 390, 396, 411, 412, **413**, 414
Chlamydomyxa 109
 Chlorarachnida 56, 180
Chlorarachnion 65, **182**, 447
 — *reptans* 181
 Chlorarachniophyceae 56
Chlorella **199**, 201, 423, 429, 444, **445**, **446**
 Chlorobionta **48**, **51**, 192, 193
Chlorobotrys 109
 Chlorococcales 201, 202
Chlorococcum **199**, 203
 Chlorodendrales 196, 198
Chlorogonium 202
 Chlorokybophyceae 196, 203, 204
Chlorokybus atmosphyticus 204
Chloromeson 109
 Chloromonada 433
 Chloromonadea 112, 456
 Chlorophyceae 57, 196, 201, **202**, 420
 Chlorophyta **31**, 51, 54, 57, 61, 78, 95, 195, 196,
197-199, **202**, **291**, 390
 Choanoflagellata 57, 59, 215, 231, 234, **235**, 433,
 456
 Choanomastigota 56
 Choanozoa 58, 215, 230, **231**, **233**, **235**, **237**
 Chonotricha 152
 Chonotrichia 154, 164
 Choreotrichia 154, 158, 160
Choriocystis **199**
 Chromista 57, 91, **92**, **94**, **98**
Chrysamoeba 102, 103
 — *radians* **100**
Chrysarachnion 102, 103
Chrysochromulina 92, 93
 — *hirta* **317**
 — *polylepis* *All*
 Chrysomonada 59, 433
 Chrysomonadea **31**, 38, **65**, 101, 102, **100**, **101**,
103, **104**, **263**, 456
 Chrysomonadida 9, 102, 103
 Chrysophyceae 56, 101

- Chrysophyta 56
Chrysothephanosphaera 103
 Chytridiales 216, 217
 Chytridiomycetes 56, 216
 Chytridiomycota 10, 38, 54, 56, 215, 216, 217, 253, 452
 Ciliata 53, 144, 433
 Ciliatea 53
 Ciliophora 26, 53, 54, 55, 57, 58, 59, 61, 90, 99, 117, 144, 145, 153, 154, 156, 159, 169, 218, 355, 390
 Ciliophryida 244, 251
Ciliophrys 251
Cinetochilum margaritaceum 434
Citharistes regius 121
Cladophora 198, 351
Clathrulina 251, 271
 — *elegans* 251, 360
 Clathralinidae 244
Clevelandella 176
 Clevelandellida 158, 176
Climacostomum 149, 153, 261, 314, 324, 330, 406, 459
 — *virens* 273, 423, 429, 445
Closterium 10, 205
 — *costatum* 206
 Cnidaria 215, 237, 456
 Cnidospora 53, 54, 200, 236
 Coccidea 132, 134, 136, 138, 344
 Coccidia 57, 336
 Coccidiomorpha 58
 Coccolithophorida 18
Coccolithus 93
 — *pelagicus* 92
Coccomyxa 199
Cochliopodium 28, 207, 208
Cochlosoma 73
 Cochlosomatidae 73
Codonella 160, 161
 — *cratera* 60
Codonocladium 234
Codonosiga 44, 236, 315
Coelodendrum 249
 Coelosporidiidae 228
Coelosporidium 228
 Coelotrophida 135
Colacium 11
 Coleochaetales 203
 Coleochaetophyceae 196
Coleospora 229
Coleps 145, 153, 168
 — *hirtus* 168, 434
Collozoum 249
Colpidium 150, 152, 153, 171, 325
 — *campylum* 430
Colpoda 125, 167, 168, 357, 373, 417, 419
 Colpodea 55, 57, 153, 154, 167, 168, 438
Colpodella 118, 124, 126
 — *gonderi* 125, 444
 Colpodellidae 59, 117, 118, 125, 126
Colponema loxodes 41
Conchophthirus 152
 — *curtus* 258
Condylostoma 157
Coniculostomum monilata 358
 Conjugatophyceae 56, 203, 204, 205, 206
 Conjugatophyta 56
 Conoidasida 132
 Conosa 37, 58, 65, 205, 208, 209, 212
Convoluta roscoffensis 197
 Copepoda 456
Corallomyxa 208
Coronympha 13
 Coscinodiscophyceae 57
Coscinodiscus 108
 — *pantocseki* 105
 — *wailiesii* 457
Cothurnia 173
Crebricoma 163
Crithidia 390
 — *fasciculata* 81
Cryothecomonas 183
Cryptobia 82, 298
Cryptocercus 75, 344
Cryptococcus 228
 — *neiformans* 228
 Cryptomonada 9, 31, 50, 65, 93, 94, 95, 456
 Cryptomonadida 59
Cryptomonas 18, 96
 — *ovata* 36, 94
 Cryptophyceae 56
 Cryptophyta 56
Cryptosporidium 139, 395
 — *parvum* 138, 139, 444
Cryptothecodinium cohnii 370
 Ctenophora 215
Culex 139
 Cyanobacteria 433, 456

- Cyanophora* 193
 — *paradoxa* 192
Cyanoptycha 193
Cyclidium 27, 170, **434**
 — *glaucoma* **430**
Cymbomonas 197
Cyphoderia 38, **40**, 183
 Cyprinoidae 242
Cyrtocalpis urceolus **247**
 Cyrtophora 55
- Dactylamoeba* **28**, 208
Dactylosoma 144
 Dasycladales 198
Dasycladus 198
 Demospongia 215
Dendrocometes **165**
 — *paradoxus* 439
Dendrosomides grassei **165**
Deplauxis 341
Derbesia 198
Dermocystidium 231, 232, 234
 Desmodontidae 84
 Desmothoracida **244**, 250, **251**
Desportesia 224
 Deuteromycetes 230
Devescovina **365**
 Devescovinidae 75
Diacronema 93
 Diatomea 433, 456
 Diatomeae 104
Dictyocha 104
 Dictyochales 103
Dictyochloropsis **199**
 Dictyochophyceae 56
Dictyostela 57, 61, 211, 212, **213**, 356
Dictyostelia 58, 390
 Dictyostelida 56
Dictyostelium **213**, **280**, 299, 390, 395, 396
 — *discoideum* 362, **363**, 370
Didinium 161, **162**, 270, **367**, **407**, **408**, 411
 — *nasutum* **318**, 427
Didymium 390
Dientamoeba 72, 73
Diffugia **60**, **207**, 208, **259**, **434**
 Dikaryomycota 218
 ZWepto 161, 272, 279, 358
 Dimasigota 57
Dimorpha mutans 365
- Diniferea 123
Dinobryon 18, **100**, 102, 103
 Dinoflagellata **50**, 56, 58, **65**, 117, 118, **119**, **120**,
 123, **124**, 126, 433, 456
 Dinophyceae 56
Dinophysis 123
 — *homunculus* **120**
 — *sphaerica* **120**
 Dinophyta 118
 Dinozoa 58, 59, 118
Diphyllia rotans **64**
 Diplomonadea 61, 68, **69**, 313
 Diplomonadida 9, 56, 59, 68, 69
Diplonema 87
 Diplonemida 87
Diplothea costata **235**
 Discicristata 58, 61, 75, **75**, 89
Discoideum murocoides 364
Discomorpha pectinata **177**
Discomorphella 176
Discophrya **44**, 165
Disematostoma **434**
Distephanus 104
 — *speculum* **104**
Distigma **303**, 304
Donax vittatus **261**
Dreissena polymorpha 458
Dunaliella 202, 420
 — *tertiolecta* 370
Dysteria 163
- Ebrüida 57
Echinostelium 212
Edwardsiella tarda 450
 £ **44**, **127**, 130, 137, 139, 368, 395
 — *canadensis* **131**
 — *maxima* **130**
 — *stiedae* **127**
 Eimeriida 135
 Eithiere 9
Eleutheroschizon 135
Ellobiophrya donacis **261**
 Ellobiopsida 57
Elphidium crispum 349
 Embryophyta 193, 196, 203
Emiliania 93
Encephalitozoon **222**, 223, 224
 Enchelydium
 — *amphora* **434**

- *clepsiniforme* **434**
Enchylis **434**
Entamoeba 24, 32, **44**, 210, 331, 395, 396
— *histolytica* 20, 32, 210, 333
Enterocytozoon **222**, 223, 224
Enteromonadida 68
Enteromonas 69
— *hominis* 69
Enteropneusta 134
Entodiniomorpha 441
Entodinium **163**
Entosiphon **41**, 78
— *sulcatum* **25**, **449**
Eopharyngia 58
Epalxella 176, **434**
Ephelota **152**, 165, **368**
— *gemmipara* 367
Epidinium **441**
Epiplasmata 58
Epistylis **173**, 357
— *Iwoffi* **261**
Erastophrya chattoni **261**
Euascomycota 215, 224
Euastrum *agalma* **206**
— *apiculatum* **206**
— *pecten* **206**
Eubacteria 66
Eucarya 64
Eucomonomphidae 75
Eucoronis 249
Eudorina 202, **202**, 347
Eufolliculina **42**, **157**, **260**, **304**, **316**, 364
— *uhligi* 257, **360**, 370
Euglena 18, **44**, 78, **303**, **365**, 366, 400
— *gracilis* **11**
Euglenida **31**, **50**, 56, 61, **65**, **75**, 76, **77**, 78, 192, 271, 456
Euglenophyceae 56
Euglenozoa 57 59, 67, 75, 76, 255
Euglypha **182**, 183, 341, **365**
Eugregarinida 134
Eukaryota 46, 57, 64, 242
Eumycota 215, 218, **219**, **225**, 233
Eumyxa 58, 211, 340
Euplotes 18, **38**, 145, **150**, **159**, **334**, **337**, **340**, 346, 357, 359, 386, 390, 393, 397, 411, **420**
— *aediculatus* 447
— *antarcticus* **420**
— *balteatus* **420**
— *crassus* 352
— *daidaleos* **434**
— *moebiusi* **430**
— *musciicola* 357
— *octocarinatus* 353, **359**
— *patella* 17
— *raikovi* 354
— *vannus* **150**, **407**, **420**
Euplotidium itoi **211**
Eustigmatophyceae 56, **109**
Eustigmatophyta 56
Eustigmatos 109
Eutreptia 78
Excavata 66, 67

Fabrea 357, 414
Favella 161
Fibrocapsa 113
— *japonica* 112
Filocorticata 58
Filosea 53, 55, 56, 182
Flagellata 53, 62
Foaina **41**
Foettingeria 171, **172**, 368
Folliculina 157
— *boltoni* 457
Folliculinidae 157
Foraminifera 17, 20, 38, **40**, 57, 58, 183, **184**, **190**, 350, 425
Fragilaria **105**
Fragilariophyceae 57
Frenkelia 137 139
Frontonia **149**, 170, **261**, 357, 423
— *leucas* **434**
— *vernalis* **434**
Fungi 61, 182, 215, 216, **217**, **219**, 224, 232
Furgasonia 167, 373
— *blochmanni* **376**
Fusulinida 187

Gambierdiscus 124
— *toxicus* 123
Gastropoda 456
Geleia **153**, 156
Gemmocystis 135
Giardia 24, **69**, 70
— *intestinalis* 333
— *lamblia* 357, 395
Glabratella sulcata 349

- Glaucocystis* 192, 193
 — *nostochinearum* 192, **193**
Glaucocystophyceae 56
Glaucocystophyta **50, 51, 56, 61, 190, 192, 193**
Glaucoma 390
 — *ferox* 147
 — *scintillans* **430**
Glenodinium 420
Globigerina 190
 — *bulloides* **189**
Gloeochaete 193
Glossina 83, 84
Glugea **222, 223, 224**
Gobiella 214, 318, **321**
Goniodoma acuminatum **120**
Goniomonas **26, 30, 282**
Gonyostomum 113
Gonium 202, **202**
Gonospora beloneides **310**
Gonyaulax 123, 334
 — *tamarense* 123
Granuloreticulosa 57, 183, 185
Granuloreticulosea 55, 59
Gregarina **44, 134**
Gregarinae **132, 133**
Gregarinia 57
Gregarinida 53
Grellia 135
Gromia **40**
Gromiida 182, 213
Grossglockneria 318
Guillardia 96
 — *retio* 95
Gymnamoebae 205, 213, **207**
Gymnochloa 182
Gymnodinium 124, 193, 318, 420
 — *acidotum* 121
 — *tena* 189
 — *ftreve* 121
 — *catenatum* 123
 — *chlorophorum* 121
 — *eucyaneum* 121
 — *galatheanum* 121
 — *mikimotoi* 121
Gymnosphaera 252
Gymnosphaeridae **244**

Haematozoa 132, 139, **140 144**
Haemogregarina 135

Haemoproteus 143
Haemosporida 143, 344
Haemosporidia 139
Halimeda 198
 / *tena* **160, 345, 367**
 — *grandinella* **434**
 chlorigella **434**
Haplophrya 176
Haplospora 59, 117, 176, **177, 178, 179, 253, 254**
Haplosporea 56
Haplosporidia 56
Haplosporidium 176, **177, 179**
Haplozoon axiothellae **119**
Haptoglossa 117, 277
 — *mirabilis* **278**
Haptomonada **65, 91, 299**
Haptophrya 368
Haptophyta 91
Haptoria 154, 161, 275
Hartmannella 207, 208
 — *vermiformis* 450
Hastigerina 190
Hausmanniella 167, **168**
Hedraiophryidae **244**
Hedraiophrys 252
Hedriocystis 251
Helicosporidium **200, 201**
 — *parasiticum* 199
Heliochona 164
Heliozoa 53, 56, 58, 59, 243
Heliozoa 55, **243, 250, 251, 456**
tfe/ 298
Hemiascomycota 215, 224, 227
Hemimastigophora 59, 76, 89, **90**
Hemimastix 89
 — *amphikineta* **90**
Hemiohrya **427**
Henneguya 242
Heterokaryota 58
Heterokonta 38, 61, 96, **98 100, 105, 109, 110,**
 111, 112 115, 179, 291
Heterolobosa 37, 57, 67, 75, 87, **88**
Heterolobosea 59, 421
Heteromonadea 108
Heterophryidae **244**
Heterophrys 252
 — *marina* **252**
Heterosigma 113
 — *akashwo* 112, 452

- Heterostegina* 190
 — *depressa* **189**, 350
Heterotrichea 154, 155, 156, **157**, 305
Heterotrichida 157, 456
Hexactinellida 215
Hexamita 70, 422
Histiona 67
Histioneis remora **120**
Histomonas 72
Holocanthida 247
Holomastigotidae 75
Holophrya 168
Holospira 448
 — *elegans* **449**
Holosticha **434**
Holotricha 152, 155
Homalozoon 161, **162**, **274**, 279, **289**, **307**, **343**
Hyalodiscus 38, 214, 318, **321**
 — *predatus* **39**
Hyalogonium 202
Hyalophysa 171
 — *chattoni* 357
Hyalosphenia 208
 — *papilio* 429
Hymenomonas carterae 351
Hymenostomata 386
Hymenostomatia 154, 170, 171, 388
Hypermastigida 27, 73, **74**, 75, 366
Hyphochytriomycetes **114**
Hyphochytrium **114**, 115
Hypocoma **153**, 163
Hypotrichia 154, 158, 159, 166, 386, 393, 438, 456
Hypotrichidium conicum **434**
- Ichthyobodo* 82
Ichthyophonus 231, 232, 234
 — *hoferi* 232
Ichthyophthirius **153**, 171
 — *multifiliis* **172**, 439
Ichthyosporea 231
Ichthyosporidium 212
Infusoria 9, 53, 144
Intramacronucleata 154, 157, **159**, **162**, **163**, **167**—**170**, 176
Isomita 58
Isonema 87
Isozona 137, 139
Isotricha **153**, 298
- Ixodidae* 143
- Jakoba* 67
Joenia **29**, **38**, **42**, **44**, 75, 366, **451**
 — *annectens* **32**, **74**
- Kalotermes flavicollis* **74**
Karotomorpha 91
 — *bufonis* **98**
Karyoblastea 56
Karyolysus 135
Karyorelictea 55, 57, **153**, 154, 155, **156**
Karyorelictida 150, 155
Katablepharis 96, 197
 — *remigera* **95**
Keronopsis 161, 390
 — *rubra* 388
Kinetofragminophorea 154, 373
Kinetoplasta 61, 76, **78**, **79**
Kinetoplastida 56, 433
Kinetoplastidea 390
Klebsormidiophyceae 196, 203, 204
Klebsormidium 204
Klossia 135
Koruga bonita **71**
- Labyrinthomorpha* 54, 55
Labyrinthomyxa 253
Labyrinthula 110, **111**, 344
 — *coenocystis* **110**
 — *macrocystis* 110
 — *zosteræ* 110
Labyrinthulea 38, 55, **65**, 109, **110**, **111**, 456
Labyrinthulida 56, 109
Labyrinthulidae 109
Labyrinthulomycota 56, 109
Labyrinthuloides 111
Lacrymaria 161
 — *olor* 17, **306**
Lamblia **69**
Lateromyxa 114, 318, 341
 — *gallica* **214**, **336**, 343, **344**, 357
Lecythium 182, 183
Legionella pneumophila 448, 450
Leishmania 83, 84, 87, 395
 — *donovani* 86
 — *infantum* 87
 — *mexicana* 370
Lembadion **359**

- *magnum* **434**
Lemna minor 426
Lepidodinium 124
 — *viride* 121
Lepidotrachelophyllum **28, 153, 161**
Leptomyxa 208
Leptotheca elongata **237**
Leucaena leucocephala 441
Leucocytozoon 143
Licmophora flabellata **105**
 Licnophorida 157
Lieberkuhnia **185, 190**
Listeria monocytogenes 450
Lithodesmium undullatum **106**
Litonotus 161, **162**
 Litostomatea 55, 57, **153, 154, 161, 162, 163, 346**
 Lobosa 37, 38, 58, 61, 205, 213, **207**
 Lobosea 55, 56
Loma 222
Lophomonas 75
Lotharella 182
 — *amoebiformis* 181
Loxocephalus luridus **434**
 Zoxoufes 18, **156, 272, 406, 407, 409, 423, 424**
 — *magnus* **434**
 — *striatus* **434**
 Loxodida 155, 156
Loxophyllum 161, **162, 271, 274, 279, 308**
 — *meleagris* **37, 346**
Lutzomyia 83
- Macrochloris* **199**
Malawimonas 67
Mallomonas 101
Mamiella 197
 — *gilva* **197**
 Mamiellales 196, 197
Mantoniella squamata **197**
 Manubrispora 58
Marteilia 253, 254
 — *refringens* 254
 Martelliidea 56
Massartia 193
Mastigamoeba 210
Mastigella 209, 210, 448
Mastigina **209, 210**
Mastigophora 53-55, 62
 Mastigota 57, 62
Mattesia 134
- Mayorella* 37, **40, 208**
 — *viridis* 429
Medicago sativa **441**
Mesodinium 161
 — *rubrum* **47, 161, 447**
 Mesomycetozoa 215, 230, **231, 232, 233**
Mesostigma 194, 204
 — *vincens* **203**
 Mesostigmatales 203
 Mesostigmatophyceae 196, **203**
 Metakaryota 57
 Metamonada 58
Metaphrya **152**
 Metazoa 8, 10, 46, **48, 61, 182, 215, 230-232, 236, 237, 456**
Metchnikovella 224
 Metchnikovellidae 55, 223
Metopus 422, 442
 — *contortus* **32**
 — *curvatus* **434**
 — *undulans* **434**
 Mezomycetozoa 37
Micrasterias 205
 — *denticulata* **206**
 — *melitensis* **206**
 — *trigemina* **206**
Microgemma 222
Microgromia 185
 Microspora 20, 44, 54-57, 61, **200, 215, 218, 219-222, 331**
 Microsporea 55, 56, 215, 218, 223, 224, 253
 Microsporidia 20, 53, 59
 Microsporididea 55
 Microthoracida 167
Microthorax 167
 Microzoaires 10
 Miliolida 187, 188
Minchinia 179
 — *louisiana* **178**
 — *nelsoni* **178**
 Miozoa 58
Mixotricha paradoxa 73, 297, 451
Mnemiopsis leidyi 458
 Mobilida 175
 Monadofilosa 58, 179, 180, 182, **182, 183**
Monas 9, 17
 Monera 10
Monocercomonas 73
Monocercomonoides 71

- *hausmanni* 70
Monocystis 134, 340
Monodinium balbiani 434
Monodopsis 109
Monosiga 234
 — *ovata* 341
 Monothalamea 185
 Mrazekidae 219, 222
Multicilia 205, 207, 208
 Muscidae 84
 Mycetozoa 53, 58, 59, 211, 212, 214
 Mycetozoea 55
Mycoplasma 450
 — *hominis* 73
Mylestoma 176
 — *anatinum* 434
Myrionecta 161
 — *rubra* 47, 161
Myrmecia 199
Myxobolus 237, 241, 242
 — *cerebralis* 237, 238, 239, 240, 241, 242
 — *pfeifferi* 242
Myxogastra 57
Myxogastrea 8, 61, 211, 212, 356, 364, 390
Myxomycotina 56
Myxosporea 55, 56, 239
Myxosporidia 20, 53
Myxozoa 8, 20, 44, 54, 57, 59, 200, 215, 236,
 237, 238, 239, 240, 241, 242, 253, 343, 454

Naegleria 88, 89, 359, 360, 422, 443, 450
 — *andersoni* 422
 — *australiensis* 88, 421, 422
 — *carteri* 422
 — *chilensis* 422
 — *clarki* 422
 — *fowleri* 88, 322, 421, 422, 458
 — *fultoni* 422
 — *galeacystis* 422
 — *gruberi* 422, 357, 359
 — *indonesiensis* 422
 — *italica* 422
 — *jadini* 422
 — *jamiesoni* 422
 — *lovaniensis* 422
 — *minor* 422
 — *morganensis* 422
 — *niuginensis* 422
 — *pagei* 422
 — *pringsheimi* 422
 — *pussardi* 422
 — *robinsoni* 422
 — *sturti* 422
 — *tihangensis* 422
Nanochlorum 201
Narcomedusa 237
Nasselaria 249
Nassellarida 246
Nassophorea 55, 57, 153, 158, 162, 166, 167, 169
Nassula 18, 38, 153, 167
 — *ornata* 167
Nassulida 167
Navicula 108
Nebela 37, 40, 208
Nematoda 456
Neocallimastigales 217
Neocallimastix 216, 217
 — *frontalis* 217
Neochloris 199
Neogregarinida 132, 134
Neomonada 58
Neozoa 58
Nephridiophaga 229
 — *apis* 228
 — *blattellae* 229, 230
Nephridiophagidae 215, 228, 229, 230
Nephroselmis 197
 — *olivacea* 366
Neurospora 395
Nitzschia 108
Noctiluca 121, 122, 124, 338, 421
 — *scintillans* 121, 123, 309, 421
Nosema 222, 224
 — *apis* 221, 223,
 — *bombycis* 20, 223
 — *locustae* 223
 — *tractabile* 220
Nuclearia 38, 39, 40, 214
Nyctotherus 176
 — *cordiformis* 346

Ochromonas 30, 103, 294, 315
 — *danica* 295
 — *tuberculatus* 273
Octomitus 70
Odontella 108
 — *aurita* 105
 — *sinensis* 457

- Odontostomatida 158, 176
 Oedogoniales 201
Oedogonium 319, 321
Oikomonas 103
 Oligohymenophorea 55, 57, 153, 154, 169, **170**–
 177, 296
Oligotrichia 154, 155, 158–160
Olpidium 217
 — *brassicae* 453
Onychodromus 390
 — *quadricornutus* 359
Oodinium 121, 122, 124, 288
 Oomycetes 10, 61, 115, 271
 Oomycota 54, 57
 Oozoa 9
Opalina **99**, 100, 296–298, 336, 404
 — *ranarum* **99**, 349
 Opalinata 53, 55, 56
 Opalinatea 55
 Opalineae 97, **99**
Opercularia 367
Ophrydium 173, 174
 — *versatile* 425, 427
Ophryodendron 152
Ophryoglena 171, 414, 436
 — *atra* 171
Ophryoscolex 162, 163
 Opisthokonta 61, 214–216, 217, 231, 315
Orbitolina 186, 190
Orbulinella 251
Orchitophrya 170
 — *stellarum* AAA
Ornithocercus 124
 — *magnificus* 120, 121
Oryctospora 229
Oscillatoria 316, 320
Oscillosignum 434
Ostrea edulis 253
 Oxymonada 59
 Oxymonadea 70
 Oxymonadidae 70
Oxymonas 71
Oxyrrhis 269
Oxytricha 372, 386, 388, 390, 392, 393
 — *fallax* 37A, 388, 420
 — *nova* 388
Palmellococcus 199
Pandorina 202
 Parabasalea 61, 71, 72, 333
 Parabasalia 52, 56, 59
Paramarteilia 253, 254
 — *orchestiae* 253
Paramastix 89
Paramecium 29, 34, 36, 38, 44, 147–149, 152,
 168, 170, 256, 257, 260, 265, 267, 268–270,
 276, 279, 281, 282, 283, 287–289, 294, 295,
 296, 297, 298, 309, 314, 318, 326, 327, 329,
 331, 333, 334, 335, 339, 343, 345, 346, 355,
 356, 370, 371, 372, 373, 378, 386, 387, 390,
 392, 393, 395, 400, 401, 402, 404, 405, 406,
 407, 409–412, 447, 448
 — *aurelia* 338, 346, 352, 447
 — *bursaria* 199, 346, 352, 386, 412, 423, 446
 — *caudatum* 30, 37, 151, 170, 286, 287, 338,
 351, 352, 353, 354, 369, 407, 427, 430, 449
 — *multimicronucleatum* 352, 412, 417
 — *tetraurelia* 333, 334, 345, 370
Paramyxa 254
 Paramyxia 56, 179, 252, 253, 254
 Paramyxidea 56
Paraphysomonas 101
 — *cylicophora* 295
Parauronema 334
Paraurostyla 373, 374, 390, 393
 — *weissei* 372, 376, 388
Parrellina hispidula 186
Paruroleptus 434
Parvicorbicula 236
Parvilucifera 125
 — *infectans* 125
Paulinella 183
 — *chromatophora* 182, 193, 444
Paulsenella 318
Pavlova 93
Pediastrum 203
Pedinella 103
 Pedinellida 102, 103
 Pedinellophyceae 56
 Pedinophyceae 59
 Pelagophyceae 59
 Pelobiontida 59, 209
Pelodinium reniforme 434
Pelomyxa 209, 210, 336, 368, 448
 — *palustris* 209, 210, 434
 Peniculia 154, 169
 Pennales 108
Pentatrachomonas 73

- Peranema* 75, 76, 78
 Percolozoa 58
 Peridinea 120
Peridiniopsis 318
Peridinium 18
 — *balticum* 121, 336, 447
 — *bipes* 119
 — *divergens* 120
 — *foliaceum* 121
 Peritricha 152, 157, 173, 175
 Peritrichia 154, 172, 456
Peritromus 157
 Perkinsida 55
 Perkinsozoa 117, 118, 124, 126
Perkinsus 117, 118, 124, 125, 126
 — *marinus* 124
 Peronosporomycetidae 57
Pfiesteria 124
 — *piscicida* 123
 Phacodiniidia 154, 158
Phacodinium 158
 — *metchnikoffi* 159
Phacus II, 78
 Phaeocalpida 249
 Phaeoconchida 249
 Phaeocystida 249
Phaeocystis 92, 422, 452
 Phaeodarea 38, 55, 249, 249
 Phaeodaria 56, 59
 Phaeodendrida 249
Phaeodina 249
 Phaeogromida 249
 Phaeogymnocellida 249
 Phaeophyceae 57, 61
 Phaeophyta 10, 48, 54, 57, 96
 Phaeosphaerida 249
Philasteria 170
Phlebotomus 83, 84
Phreatamoeba 210
 Phyllopharyngea 55, 57, 153, 162, 163 165
 Phyllopharyngia 163
Physarum 212, 301, 302, 384, 390, 392
 — *confertum* 212
 — *polycephalum* 44, 370
 Phytomastigophorea 55, 62
 Phytomonadea 201
Phytomonas 87
 Phytomyxa 58, 179, 181, 452
Phytophthora 117
 — *infestans* 115
Pinnularia viridis 105
Piromyces 216, 217
Piroplasma 144
 Piroplasmida 139, 143, 344
Plagiopyla 169
 — *frontata* 32, 169
 Plagiopylea 154, 168, 169
 Plants 61
 Plasmodiophora 59
Plasmodiophora 180, 181, 452
 — *brassica* 180
 Plasmodiophorea 55, 179
 Plasmodiophorida 56
 Plasmodiophoromycota 54, 56
Plasmodium 20, 33, 139, 141, 142 144, 310, 390,
 393 395, 411
 — *falciparum* 33, 142, 143, 370, 393, 394, 395
 — *knowlesi* 142
 — *malariae* 142, 393
 — *ovale* 142, 393
 — *vivax* 140, 142, 393
Plasmopara 111
 — *viticola* 116
Platymonas convolutae 197
Pleistophora 222, 224
 — *hyphessobryconis* 219
Pleodorina 202
Pleurochrysis 28, 93, 257, 259
Pleuronema 170
 — *coronatum* 435
Pleurosigma 108
Pleurotricha 390
 — *indica* 388
 Plicostoma 58
 Pneumocystidales 224
Pneumocystis 86, 215, 225, 444
 — *carinii* 224, 225, 226, 227
Pocheina 89
Podolampas 124
 — *bipes* 121
 Polycystina 55, 56, 59
 Polycystinea 38, 53, 245 248
 Polyhymenophorea 154
Polykrikos 122, 278
 Polymastigidae 70
Polymyxa 452
Polynucleobacter necessarius 447
Polyphagus 216, 217

- Polysphondylium* 213
Polyspira delagei **361**
Polytoma 202
Pontomyxa 185
Porphyridium 192
— *omentum* **191**
Postciliodesmatophora 55, 154, 155, **156, 157**
Postgaardi 76
Poterioochromonas 262, **263, 295**
— *malhamensis* **100, 263**
Prasinomonadea 9, 196
Prasinomonas 198
Prasinophyceae 57, 59
Primociliata 90
Prochlorophyta 433
Prokaryota 10
Prorocentrum 124, 343
— *minimum* 370
Prorodon 18, 168, **434**
Prostomatea 55, 57, **153, 154, 167, 168, 438**
Protalveolata 58
Proteromonadea 97, **98**
Proteromonadida 9, 56
Proteromonas 97
— *lacertae-viridis* **98**
Proterospongia 234
— *haeckeli* **235**
Protista 8, 10, 11, 17, 60
Protococcida 134, 135
Protocruzia **153, 155, 158, 343**
Protocruziida 154, 158
Protoctista 10, 11, 54, 56, 61
Protoheterotrichida 155, 156
Protoopalina 100
Protoperidinium 122, 124
— *conicum* **322**
Protostela 57
Protostelea 38, 211
Protostelida 56
Protostelium 211
Protostomatida 155, 156
Protozoa 7-11, 20, 53-55, 58, 61
Prymnesiida 59
Prymnesiomonada **50, 65, 91, 92, 93, 315, 433**
Prymnesiophyceae 56
Prymnesiophyta 56
Prymnesium 93
Psamminida 56
Pseudobodo 113
Pseudociliata 56, 58, 90, **91**
Pseudococcomyxa **199**
Pseudodiffugia 182, 183
Pseudomicrothorax **29, 35, 147, 167, 282, 314, 316, 319, 320, 324, 357**
— *dubius* 317, 324, 429, **459**
Pseudomonas 450
Pseudo-nitzschia 107, 108
— *australis* 107
— *multiseriis* 107
— *pseudodelicatissima* 107
— *pungens* 107
— *seriata* 107
Pseudoplatyophrya **153, 318**
Pseudocourfeldia 197
Pseudocourfeldiales 196, 198
Psorospermium 231, 232, 234
— *haeckeli* **231, 232, 233**
Psychodidae 84
Pteridomonas 103, 251
Pyramimonadales 196, 197
Pyramimonas 197
— *tetrarhynchus* **197**
Pyrenomonas 96
Pyrgidium pyriforme **120**
Pyrsonympha 71
Pyrsonymphida 56
Pyrsonymphidae 70
Pythium 116, 117

Radiolaria 53, 58, 243
Radiophrya **176, 368**
Radiosphaera **199**
Radiozoa 58
Raphidiophrys contractilis **271**
Raphidomonadea **112**
Raphidomonadida 59
Raphidonema 204
Raphidophyceae 56
Raphidophyta 56
Rastrimonas 125
Reclinomonas 67
Reduviidae 84, **85**
Remanella 156, 435, **436**
Reticulofilosa **50, 58, 179, 180, 182**
Reticulomyxa 38, 185, 190, 279, 425
— *fllosa* **39, 184, 185, 425, 457**
Reticulosphaera 109, 180
Retortamonada 57

- Retortamonadea 67, 68, 313
 Retortamonadida 56, 59
Retortamonas 41, 67, 68
 Rhabdophora 55
Rhagadostoma 434
Rhinosporidium 234
 — *seeberi* 231, 234
Rhizidiomyces 114, 115
Rhizochloris 109
Rhizophyidium sphaerotheca 217
 Rhizopoda 53, 54, 56, 62, 179, 209
 Rhizopodea 55
Rhizosolenia 108
Rhodnius 83, 84
Rhodomonas 29, 30, 96, 258
 Rhodophyceae 56
 Rhodophyta 10, 50, 51, 54, 56, 61, 95, 190, 191, 192
 Rhynchodia 163
Rhynchomonas nasuta 82
Rhynchopus 87
Rhytidocystis 135
Rickettsia 450
Rotaliella 190, 349
 — *heterokaryotica* 190, 336
 Rotaliida 187, 188
 Rotifera 456
 Rudimicrospora 223
 Rudimicrosporea 55, 56

Saccamoeba 37, 40, 44, 208
Saccharomyces 227, 395
 — *cerevisiae* 224, 227, 386
Saccinobaculus 71
 Saccostoma 58
 Salivaria 379
Salmonella 450
Salpingoeca 234, 236
 — *amphoridium* 235
 — *cornuta* 235
Saprodinium 176, 434
 — *putrinium* 177
Saprolegnia 115, 116, 117
 Saprolegniomycetidae 57
Sarcozystis 137 139, 368
 — *equicanis* 138
 — *ovifelis* 138
 — *suihominis* 138
 Sarcodina 17, 53 55, 62, 87, 242

Sarcomastigophora 17, 53 55
 Sarcomastigota 58
 Sarcomonadea 183
 Sarcosporidia 20, 53
Scenedesmus 203
 Schizocladidae 59
 Schizopyrenida 421
 Schizopyrenidea 61, 88, 205
Schizosaccharomyces pombe 227
 Schizosaccharomycetales 227
Schwagerina 190
 Scleractinia 122
Scotiellopsis 199
 Scuticociliata 170, 434
 Scuticociliatia 154
 Scuticociliatida 456
Selinidioides 134
 Sessilida 173
Shigella 450
Siedleckia 134
 Silicoflagellata 56, 59
 Silicoflagellida 102, 103, 104
 Sipunculida 134
 Slopalinida 59
Sonderia 169
Sorites 186
Sorogena 153, 167, 263, 264, 356, 419
Sorosphaera 180
 Spasmaria 58
 Spermatozoa 15
Sphaeroeca volvox 234
Sphaeromonas 216, 217
Sphaeroforma arctica 234
Sphaerosoma 242
Spirochona 162, 425
 — *gemmaipara* 164
Spirogyra 319
Spiromonas 125, 126
 — *gonderi* 444
Spirotrichia 89
Spirotrichia 70
Spirophrya 171
 — *subparasitica* 361
Spirostomum 18, 152, 157, 279, 403, 406, 423
 — *teres* 434
Spirotaenia condensata 206
 Spirotricha 152
 Spirotrichea 55, 57, 153, 154 156, 158, 159
 Spirotrichia 166

- Spirotrichonymphidae 75
 Spizellomycetales 217
Spongiochloris **199**
Spongospora 180, 452
 Sporozoa 19, 20, 53, 54, 58, 126, 218
 Sporozoasida 55
Spraguea **222**
Spumella **315**
 Spumellaria 249
 Stanomida 56
 Staurastrum
 — *aculeatum* **206**
 — *furcatum* **206**
 — *paradoxum* **206**
 — *spinosum* **206**
 — *vestitum* **206**
Staurojoenina **35**
Stentor 36, 157, 260, 272, 273, 304, 343, 357,
 370-373, 375, 376, **377**, 403, 406, 414, 425
 — *coeruleus* 157, 272
 — *igneus* 157
Stephanopogon 76, 90, 91, **91**
 — *apogon* 90
Stereomyxa 37, **40**, 208
Stereonema 89
Stichococcus 204
Sticholonche 251
Stichotricha 161
Stichotrichia 154, 155, 158, 159, 161, 386, 388,
 456
Stokesia vernalis **434**
Stomoxys 83
 Streptophyta 61, 195, 196, **203**, **206**
Strobilidium 161
 — *velox* **434**
Strombidinopsis 161
Strombidium 160, **434**
 — *viride* **434**
Stylocephalus 134
 — *longicollis* **133**
Stylochona 164
Stylonychia **41**, **152**, **153**, **161**, **316**, **340**, 346,
 358, 386, 387, 390, 392, 393, 397, 403, 406,
 434
 — *lemmae* **345**, 346, 370, **386**, 388
 — *mytilus* 17, 388, **397**
 — *pustulati* 388
 Suctoria 53, 152, 154, 164, 360, 367, 456
Symbiodinium 108, 122, 124, 189
 Symphyacanthida 247
 Syndinea 123
 Syndiniophyceae 56
Syndinium 124
Synedra gracilis **105**
Synhymenia 166
 Synhymeniida 166
Synura 18, 101, 103
 — *petersenii* **101**
 Synurophyceae 59
 Tabanidae 84
Tabanus 83, 84
Tabellaria **105**
 — *flocculosa* **105**
Tachyblaston 368
 — *ephelotensis* 367
 Taxopodida 251
Telohania **222**
 Telosporea 53
Teratonympha mirabilis **74**
 Testacealobosea 205, **207**, 208, 213
Tetrahymena 26, 40, **44**, 149, 170, 171, 337, 338,
 346, 369-371, 373, 374, 378, 386, 387, 389-
 393, 395, 436, 455
 — *americanis* **455**
 — *australis* **455**
 — *borealis* **455**
 — *canadensis* **455**
 — *capricornis* **455**
 — *cosmopolitanis* **455**
 — *hyperangularis* **455**
 — *pigmentosa* **455**
 — *pyriformis* 171, 345, 369, 386, **455**
 — *thermophila* 171, 338, 353, 369, 370, 376,
 386, 389, 391, 392, 393, 450, **455**
 — *tropicalis* **455**
 — *vorax* 358
 Tetramastigota 57, 61, 66, 67, 68
Tetramicra **222**
 Tetramitia 58
Tetramitus 88, 89, 359, 360, 448
Tetramyxa 180
Tetraselmis 197, 198
 — *bichlora* 197
 — *convolutae* 197
Tetraspora 241
Tetratoxum parvum 163
Textularia 190

- Textulariida 187
 Textullaria 188
 Thalassiosira 107
 Thalassomyxa 214
 — *australis* **214**
 Thallasicolla 249
 Thaumatomonas 183
 Thecamoeba **35**, 208
 — *terricola* 419
 Theileria 144
 — *annulata* **144**
 Thraustochytrida 56
 Thraustochytriidae 109
 Thraustochytrium 111
 Tintimidium 161, 367, **434**
 Tintinnina 160
 Tintinnopsis **160**
 — *subacuta* 367
 Tokophrya **165**, 260
 — *lemnae* 426
 Tontonia 160
 Toxoplasma 33, 86, 137, 139, 364, 395
 — *gondii* **128**, **136**, 137, 395
 Toxoplasmea 53
 Trochopoda **244**
 Trachelius 161
 — *ovum* 427
 Trachelocerca **156**
 Trachelomonas 11, 192
 Trachelonema 156, 272
 — *sulcata* 275
 Tracheloraphis 156
 — *dogieli* 275
 Trebouxia **199**, 201, 423, 444
 Trebouxiophyceae 196, 198, 199, **200**
 Trepomonas 70, 422
 Triadopsis 298
 Triatoma 83, 84
 Tribonema 108
 Triceratium *distinctum* **105**
 Trichia 212
 Trichoctomatia 162
 Trichodina **175**, 176, 260, **262**, 264, **308**, 309,
 324
 — *cyprinis* 175
 — *pediculus* 175, **449**
 Trichomitopsis *termopsidis* **72**
 Trichomonadida 9, **72**, 73
 Trichomonadidae 72
 Trichomonas **44**, 73
 — *foetus* 73, 332
 — *hominis* 13
 — *termopsidis* **72**
 — *vaginalis* 73, 332
 Trichomycetes 218
 Trichonympha 21, 323, 338
 Trichonymphidae 75
 Trichophrya **153**
 Trichosidae 59
 Trichostomatia 154, 161, 162
 Trichozoa 58
 Trigonomonas 70
 Triloculina 190
 Trimastix 67
 — *marina* **66**
 Trimitus 69
 Trimyema *minutum* 420, **421**
 Trinema **44**, 183
 Trithigmostoma 313
 — *sto'm* **374**, **375**
 Tritrichomonas 13
 — *angusta* **41**
 — *foetus*
 Trochiscia **199**
 Troglodytella 162
 — *gorillae* **163**
 Trypanosoma 20, **44**, 83, 84, 87, 361, 379, 383,
 390
 — *braziliensis* 83
 — 27, **32**, **79**, **81**, 84, 370, 380
 — *brucei* 83
 — *gambiense* **84**
 — *rhodesiense* 83
 — *congolense* **81**, 83, **384**
 — *crazi*; 83, **85**, **87**, 341, 395
 — *donovani* 83
 — *equinum* 83
 — *equiperdum* 83
 — *evansi* 83
 — *fallisi* **81**
 — *gambiense* 20
 — *mega* 361
 — 341
 — *tropica* 83
 Trypanosomatidea **79**, **81**, 82, **84** **87**
 Tubifex *tubifex* 231
 Tubulicorticata 58
 Turbellaria 456

- Ulothrix* 198
Ulva 198
 Ulvophyceae 57, 196, 198
Umbellosphaera 93
Urceolaria 176
Uronema 170
Uronychia 159
Urosporidium 179
Urospora 159, 161, 390
 — *grandis* 159, 343
 Urthiere 9, 15

Vacuolaria 112, 113
Vaginicola 173
Vahlkampfia 35, 88, 89, 434
Vairimorpha 224
 — *necatrix* 223
Vampyrella 35, 214, 318, 341, 429
 — *lateritia* 27, 30, 214
 Vampyrellidae 213, 336, 344
 // 38, 40, 205, 207, 208
 — *simplex* 27, 43
 Vannellidae 456
Vaucheria 108
 Vegetabilia 10
Vibrio cholerae 450
 Viridiplantae 50, 51, 192, 193, 195, 196, 197, 203
 Volvocales 201, 202
 Volvocida 8, 59, 196, 201, 202, 338, 341, 347
Volvox 202, 347, 366, 425
 — *aureus* 347
 — *carteri* 347, 366, 367
 — *globator* 347
 — *perglobator* 347
Vorticella 9, 44, 152, 173, 260, 305, 306, 423,
 425, 427, 429, 434
 — *bosminae* 434

 Warnowiidae 122
Willaertia 89
Woloszynskia pascheri 448

 Xanthophyceae 57, 108
 Xanthophyta 57
 Xenophyophora 56
 Xenophyophorea 55, 59, 187

Zelleriella 100
 Zoomastigina 56
 Zoomastigophorea 55, 62
 Zoophyta 10
 Zoophytes Infusories 10
Zoothamnium 362
 — *alternans* 347, 361, 362
 — *arbuscula* 174, 361, 362
 — *niveum* 174
Zooxanthella 122, 124
 Zygematophyceae 196, 204
 Zygomycetes 218
 Zygomycota 215, 217, 218

	3
	4
	6
I.	7
	7
	12
	24
	24
	36
	41
II.	45
	45
	53
	64
III.	255
	255
	255
	260
	265
	277
	279
	288
	311
	336
	339
	339
	356
	356
	360
	364
	370
	379
	379

.....	383
.....	385
.....	393
.....	394
.....	397
.....	399
.....	401
.....	404
.....	415
.....	415
.....	430
.....	436
.....	438
.....	453
.....	459
.....	461
.....	477

:

2010. 495

: . . .
: . . .
: . . .
: . . .

123100,

, / 16,

mikhailov2000@gmail.com

http://avtor_kmk.ru

18.05.2010.

915

70x100/ 16.

31 . .

1000

« « »

121099,

., 6