

How to make herbarium

Alexey Shipunov

September 30, 2017

Draft



Shipunov, Alexey. *How to make herbarium: a short manual*.
September 30, 2017 version (draft). 20 pp.

On the cover: Dactylorhiza maculata herbarium, scanned image.

This work is dedicated to the public domain

*To the memory of my mentor,
Vadim Tikhomirov*

Contents

1	Herbarium collection and design	5
1.1	Preparation	5
1.2	How to collect plants	7
1.3	When you return from a trip	9
1.4	Drying	11
1.5	Labeling	13
1.6	Mounting	15
1.7	Storage and handling	15
2	Special cases	17
2.1	Mosses and lichens	17
2.2	Algae	17
2.3	Latin name	17
	Recommended literature	19

1 Herbarium collection and design

Botanical traditions vary between countries and botanical schools. Here I will describe the way plant collection is typically done in countries with German botanical tradition, e.g., in Russia and Ukraine. I believe that this way has some advantages over the typical American way, and deserves a further expansion.

1.1 Preparation

To start with, plant collection is serious work and one should always have a clear understanding of your plans.

There are at least two tools to keep with you on a collection trip: a herbarium trowel (shovel) and a field press. The **trowel** is needed to take plants out of the soil with underground parts relatively non-damaged. If the plant is too long (like grapevine) or this is a tree or big shrub, underground organs are ignored and trowel is not needed. However, you always need the trowel if you collect herbaceous plants or even small shrubs or shrublets. It is possible to use anything as a trowel (you can even dig the plant out with your hands); the best choice is a thick knife with a wide (about 3 cm or wider) blade, flat chisel or specially sharpened fragment of a steel pipe (Fig. 1.1.)¹ Typical garden or kid's trowels will not work well. You can also use a penknife but not for long since its blade will soon break and/or go blunt.

Second, you need the field press to straighten and press the plant right on the collection spot, this will preserve it in a good condition for the next stage of the process. If collection trip is short, and plants rough (e.g., do not wither fast), it is possible to gather plants into a plastic bag. However, in this last case it is possible to forget where exactly each plant was collected.

¹All pictures made by Michail Boldumanu. Many thanks to Kyle Pay for grammatical corrections.

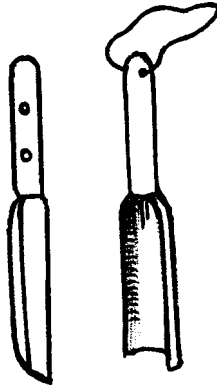

Figure 1.1: Different herbarium trowels.

The field press is essentially two pieces of plywood or cardboard with the size slightly exceeding the typical collection herbarium sheet (44×30 cm). You can make them, for instance, 34×47.5 cm. There should be 4 holes on the perimeter (for example, 2.5 cm in diameter located on 4.5 cm distances from corners); these holes will hold two straps (pieces of rope): see the Fig. 1.2. To make the field press more convenient to handle, there should be the third strap between two upper holes of the one (top) side. Place newspaper collection sheets inside, typically 20–30 per press (the number depends on how many plants you want to collect). Every collection sheet should contain one plant. Tie two main straps in bows, and field press is ready.

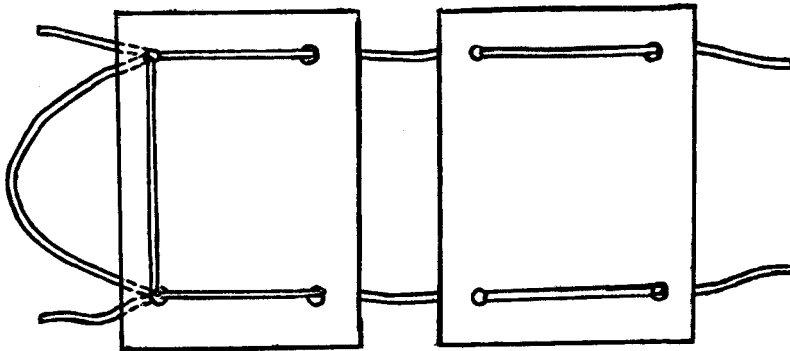

Figure 1.2: Field press.

Apart to field press and trowel, the bare minimum of collection equipment includes pencil (not pen!) and paper (preferably sticky) for labels, plus all possible field trip equipment you might find necessary, from the car to camera and raincoat.

1.2 How to collect plants

Now to the collection process. Choose the healthy, average plant with both vegetative and reproductive organs available. If plants are too big, choose smallest but not an ugly one.

Selected plant (if its is not a vine like morning glory, or big woody plant) should be taken out **with roots**. This is especially important if you collect grasses or sedges where one of the most significant determination characters is the way of vegetative reproduction (intravaginal or extravaginal), this is visible only on underground parts. Species of dock differ by the presence of taproot, and so on. If you collect a really rare plant, you may leave underground parts in soil to give it the chance to reproduce.

Immediately after digging out the plant you need to untie the field press, take the topmost (one of field press sides, side with handling strap must always be upper!) collection sheet, open it and place the plant on its half.

Next step is to straighten the plant (this is not a final straightening but still very important one). The goal is to convert 3D real-world plant into 2D herbarium sample. You will need to leave all important parts as much exposed as possible. Do not crumple! Bending is prohibited without necessity.

You should press the most of plant surface to the paper, making it flat. To hold parts flat, you can use various hard and heavy things like stones, coins, trowel etc., and finally, your own fingers. If there is a place where leaves and/or other organs (like flowers) will overlap (please try to avoid overlapping), you should put there the **small piece of paper**. Otherwise, these contact places will turn black during the drying process. Some (2–3) leaves is good to place reversely, the back side up.

By the way, these small fragments of paper are extremely useful and never do anything bad. Typically, the more of them you insert, the better is a quality of sample. Do not forget to remove them when plant is dry.

Flowers should be thoroughly straightened to show all its basic organs—calyx, corolla, stamens and pistil. If petals are fused, do not straighten them. Be very careful with delicate flowers of some plants (like flax or evening primrose). It is better not to touch them with hands but use preparation needle instead. To dry these flowers well, it is recommended to place them between two sheets of thin paper (or within one bent paper piece) and put the piece of cotton wool above. You can do the same with other complicated parts. Do not touch this flower paper until the plant is completely dry!

After straightening, slowly close the collection sheet from left to right (do not forget to remove everything which was used for holding). While holding the whole pile, take empty collection sheet **from bottom** of pile and place it above the sheet which was just used.

So far, I explained how to deal with plants which size is comparable with the collection sheet. Now for the more complicated cases.

What if the plant is bigger than the collection sheet? This is typical in grasses and grass-like plants. In these cases you should **bend** the plant, first pressing your nail to plant leaves and stems on the 1–2 cm distance from the top edge of paper. If there are many parts coming out, bend them **exactly on the same level**. Sometimes, it is more handy (but not quite aesthetic) to bend a lower part instead of upper parts. Rarely, it is possible to cut out outstanding parts—but please do not damage the plant and always leave traces of what was done (to let others know that some organs were located here).

Long plants like vines, shrubs and trees are collected in parts, typically branches with leaves and reproductive organs. Note that since it is impossible to estimate size of such plant from what was collected, collector must note the height (or length for vines) on the label.

Big herbaceous plants or plant parts. If the plant does not fit after bending from above, bend in from below. If it still does not fit, continue bending up to 5–6 times (especially if plants are narrow, like rushes and sedges). Otherwise, you might apply more damaging procedures—cut the plant in a few parts, discard what is not too valuable (typically, the middle) and keep others. Sometimes, you need to place a disintegrated plant on several collection sheets (do not forget to mention it on labels). This is how they collect **palms**.

Ferns are collected as whole but if the plant is too big, it will be enough to keep the half of the rhizome (cut it lengthwise) and 1–2 whole leaves (fronds), preferable with sporangia.

Spikemosses and other **creeping plants** might also be collected in parts. It is enough to keep one segment with roots, leaves and spikes or flowers.

Water plants are better to expand in water, on a sheet of dense white paper (like the paper used for mounting, see below) with preparation needle. This is the typical way to collect duckweeds and other plants floating in water. The dense paper sheet with the self-adherent plant is then placed inside of collection sheet.

Plant parasites should be collected with a host. Sometimes, non-green parasites will change color significantly after drying so it is better to note the color on

the label. The same is recommended for plants changing colors of their flowers (like flaxes).

Juicy plants, cacti, plants with thick roots and stems need special treatment. Sometimes, it is enough to cut out lengthwise (with sharp knife) part of the leaf, stem or root. Sometimes, it is better to leave only skin. In the extreme cases, you will need to boil the juicy part in water or even in ethanol (however, remember that last procedure will reduce the possibility of DNA extraction from the sample).

Small plants, when every plant is significantly smaller than the collection sheet, is better to collect in bigger quantities, to fill the sheet with plants. Do not do it for rare plants though.

In all, the most important on this step is to keep all significant morphological characters in place.

Do not forget to write the field label (see below) and attach it to the sheet!

When you finish collection on a particular spot, tie the field press tightly (you may want to press it with knee or even foot, but be sure that plants do not damage one another). As you see, pressing starts at the time of collection.

1.3 When you return from a trip

First thing is to prepare the drying tools and start the main straightening, the sooner the better—otherwise plants will wither completely and will be unavailable for further processing. This is especially important if weather is hot. However, in cool and humid place, the field press could lay for 5–10 hours, this is why the rain is not a problem (you can even drop the field press into water without any real damage.)

The main drying tool is a drying, permanent press (or simply “press”, do not mix it with field press!) Typically, this is two wooden frames made from 4 planks each, with several cross-bars, sometimes also with steel wire mesh on one side (Fig. 1.3). To start drying, you need to put all ready collection sheets into the press, interleaving them with drying sheets. If you have the non-printed newspaper, it is the good idea to use it for plant sheets, and use common (printed) newspaper for interleaving (drying) sheets. In that way, the danger to loose your plant by accident when changing of drying sheets is reduced.

Please note that it will be impossible to straighten the plant the third time (you can only correct some parts). If in the field you do not actually need to expand and flatten well the rough parts (they will be softer when plant wither a bit), now this should be done with all possible accuracy. Compound leaves of legumes and similar require

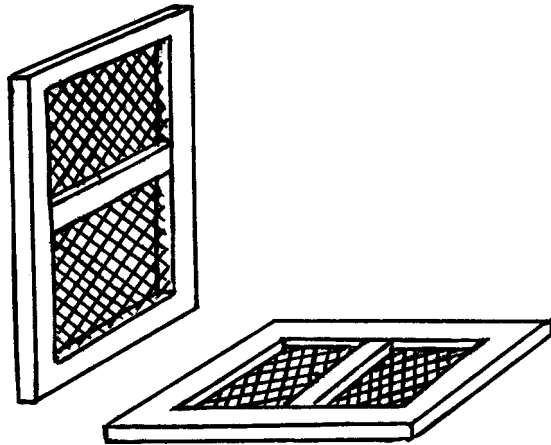

Figure 1.3: Drying press (“press”).

more work. Check plants again for crumples and unnecessary bends. Do not touch delicate parts (like flowers), but if flowers were rough, carefully place them in paper and possibly add cotton above. Fill the whole paper surface with a plant, except one corner (typically, bottom left—for label).

If there are too many parts to straighten, you might apply surgery and cut out some—but please always leave “stumps” which show that here was a part which is now removed.

When finished, close the collection sheet and put it into the press. The order is following: if the press has no wire mesh, place cardboard on its inner side (if there is a wire mesh, no cardboard required), then 2–6 drying sheets (empty newspapers), then the first collection sheet with the plant processed, then 1–2 drying sheets (more if your plant is wet and/or thick), then next collection sheet with a plant, then again drying sheets, and so on.

The total number of plants in the press varies and depends on plant type. As a rule, it is not recommended to have more than 50 plants per press. The more plants are inside, the slower and more badly they dry. When the pile is ready, put 2–6 drying sheets above, then (if there is no wire mesh) cardboard and finally, the second half of the press. Then tie it up as tight as possible. There are many ways to do it (see, for example the scheme on Fig. 1.4) but the most important is to press well. If you clench the press in a corner, and it does not contact, then it is packed well. When your press is ready, you may want to label it with today’s date; this is especially important if you have multiple presses.

First and second runs are most important for pressing while subsequent runs are more important for drying. Consequently, on the third and following days it is not necessary to tie really hard. At the end of drying cycle, it is also recommended to reduce number of drying sheets to 1 or 2 between collections.

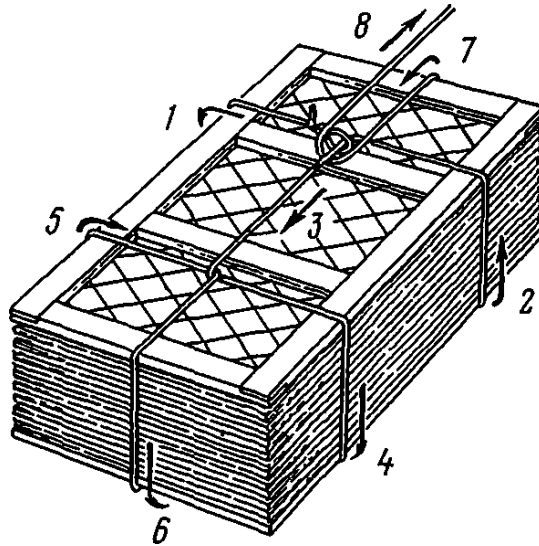

Figure 1.4: Tying the press: “typographical way” (figure is taken from Skvortsov, 1977).

1.4 Drying

If weather is dry and sunny, presses are better to keep outside. Wind will make the drying process even better. If weather is worse, drying takes place indoors. Do not apply any heating tools without careful thinking because the quality of herbarium suffers from overheating. If you must, apply heating not more than 20–30 min per hour, and turn your press every 10–15 min.

The most important factor in drying is **to change drying sheets**. Change wet sheets with the dry ones as frequently as possible (see below). You can dry drying sheets with any tools including campfire or oven, or on rope like bed sheets. When the paper rustles, it is dry enough. The drier they are and the more frequently they are changed, the higher is the quality of your collection. In the most unlikely places with the most inappropriate weather changing of sheets will produce the amazingly good results. By the way, if drying is slow, you might change also the collection sheets.

The typical “English” way of drying is to use big piles of cardboard where small holes allow for ventilation, plus warm air which comes from some heating equipment. The big plus is that you do not need to change your sheets but the quality of result could suffer significantly, especially if it is too humid around. Also, this is less portable as you should take much more equipment with you and your herbarium piles are much bigger.

* * *

To check if the plant is already dry enough is easy with your lips: if you feel the plant is cold, then it is not yet dry. Dry plants are warm. Sometimes, you might also check the dryness when you lift the plant, holding it horizontally. If some parts hang down, then the plant is still not dry, and you should continue to keep it in the press, changing drying sheets.

Typically, it is recommended to change drying sheets 2 times a day for the first 2–3 days after collection, and then once a day. Consequently, it is better to keep at least one press for each day of collection. If the environment is really dry, you might reduce it to once a day during all drying times.

On the 4–5th day, pressing is not needed so much, so you can keep these “lasting” samples in cardboards, tying them the same way as presses, and even without drying sheets.

In the end of the drying process, it is recommended to remove any dirt manually or with needle or scissors.

Now some notes about specific plant groups:

Juicy plants, including orchids, members of lily family (Liliaceae) and others, are drying extremely slowly and frequently losing color or even darken. To dry them better, you need to:

1. Take out all rear tissue from juicy parts (rhizomes, bulbs, tubers etc.). You might also boil them for 1–2 min (but this procedure could damage DNA and make the herbarium sample unavailable for molecular research).
2. Together with drying sheets, change collection sheets 2 or 3 times.
3. Never use high temperatures!

Last two items are also applicable to **conifers** which are yellowing during the drying process.

Plants from mint family, forget-me-not family, heather family (Labiatae, Boraginaceae, Ericaceae etc.) and many other plants rich of secondary compounds,

frequently darken in drying. The only way to avoid it is to change out drying sheets more frequently.

Grasses frequently change their green color into bluish, but nothing helps here. Do not forget, however, to straighten their leaf blades as flat as possible.

Bell-flowers and some other plants will lose their flower color. There is a way to prevent it: put their flowers into dry paper previously soaked in concentrated salt solution.

Flaxes not only change their color but also often lose their corolla. If this happens, put all flower parts into paper envelope (like on the Fig. 2.1). This envelope will be later glued to the mounting sheet.

Conifers often drop their needles. It is often recommended to boil them for several seconds, but this will impede DNA extraction. One workaround is to do it only for one of several branches, and collect needles from non-boiled branches within the paper envelope attached.

To lower the effect of fungal and bacterial contamination, it is sometimes recommended to spray samples with ethanol. This works, but again could damage DNA and decrease the value of the sample. Remember also that if anything outside of standard procedures was applied to the sample, it is important to mention on the label.

1.5 Labeling

Your excellent herbarium sample will drop 99% of its scientific value if the label is lost. On the contrary, badly collected sample *with the label* is sometimes of immense value. This is why you should remember about the label from the first collection steps.

From the time of field press to the end of drying each sample must have a draft label. Sticky paper is especially good for draft labeling. There are many ways of labeling but the bare minimum is:

1. **location ID** which in turn corresponds with
 - (a) **GPS coordinates**
 - (b) **date** of collection
 - (c) **names** of collectors;
2. **number of sample** (sample ID) within location;

- and some **ecological remark**. Please do not overlook this last label as the simple phrase like “in prairie” or “lake shore” may tell important information to future researchers.

There also might be a place for some additional information like

- number of associated **photograph**, this is especially handy if this photograph is the image file electronically supplied with **GPS** coordinates;
- size**—for trees, shrubs and all other plants which are collecting in parts;
- and other morphological remarks like flower and plant color, and so on.

When you finish drying, you will need a new label. This is a small (8 × 11 cm) piece of paper where everybody must find the following (Fig. 1.5):

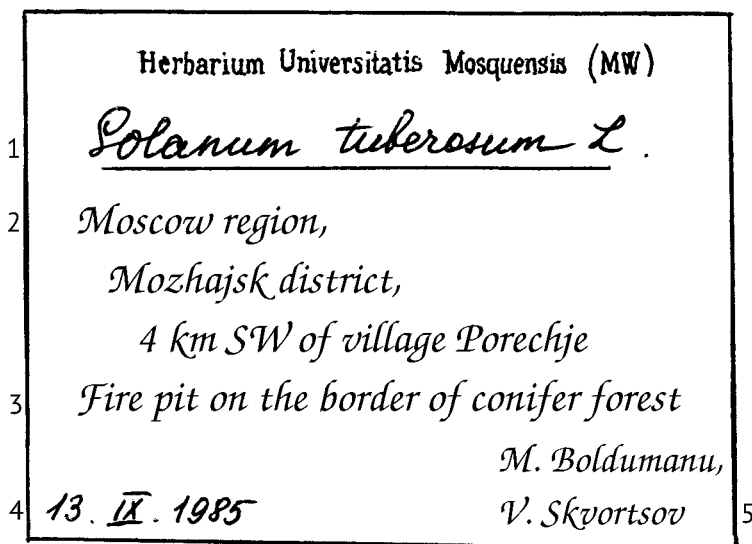

Figure 1.5: The final label.

- Latin name of the plant (optional)
- Geography of collection which must be enough to find this collection place again (GPS coordinates are preferred)
- Ecological remark: type of forest, host for parasite, orientation of slope and so on
- Date of collection
- Name(s) of collector(s). This might be needed to for future inquires.

6. Name(s) of who performed plant determination (optional)

When mounting, this label goes to the bottom right corner.

1.6 Mounting

Every collected plant must be taken out of the collection sheet and mounted—in other words, attached to the special sheet, typically of dense, long-lasting (hundreds of years are required!) paper. It is also possible to leave herbarium non-mounted but in that state samples will degrade much faster, and are more prone to accidents.

Mounting paper is the same size as the folded collection sheet, typically 41.5×29 cm, which is quite close to the standard A3 paper size. The dried plant is placed on it in such a way as to leave a place for the label.

The goal of mounting is not to attach the plant permanently but just stabilize it. All separate parts of the plant are glued with narrow stripes of special glue paper. These stripes should be parallel to the upper edge of the sheet. If some parts are thick (and possibly woody), it is better to attach them with needle and thread, leaving knots above (to avoid damage to neighboring samples). To check the quality of mounting, turn the sheet over—if some parts hang down, attach them with sticky paper or thread. Last step is to attach the label, with only a few drops of good, stable glue. And your sample is ready!

On the last note—your herbarium should be pretty. It is well known that ugly samples do not facilitate botanical research.

1.7 Storage and handling

The best way is to store herbarium in piles in a dry, cool and well ventilated room. Sometimes, you need to apply insecticide to prevent insect damage of the collection. Be careful with insecticides, they must not damage plant samples.

No food or drink is allowed in the herbarium room. Another important rule is that all herbarium users must use **both hands** to move herbarium samples.

If there is more than 100 sheets, the herbarium should be arranged in some specific order: by regions, by families (typically, in alphabetical order) or in some different but consistent way. Within large sections, sheets are frequently arranged taxonom-

ically, for example, alphabetically by genera and then by species. Within species, bigger herbaria frequently use geographic principle again.

It is agreed that herbaria belong to all people. This is why the scientific plant collections are never on sale—you can only lend or loan it, or give it as a gift. Consequently, all herbaria must be open to all public. If you send your herbarium within the U.S., it is recommended to use library rates. In other parts of the world, different rules might apply.

2 Special cases

2.1 Mosses and lichens

Mosses belong to higher plants, and lichens to fungal kingdom but collection rules are similar. They are collected as a whole, preferably with reproductive parts (sporangia, apothecia) into small paper envelopes (Fig. 2.1). These envelopes go into pressing and drying, and the herbarium (of course, with the label) is ready.

2.2 Algae

To collect algae, one can use the approach described above for water higher plants: straighten them under water on a dense paper sheet. However, do not detach them from that sheet after drying. Also note that brown and red algae will lose their (taxonomically important) color if you keep them in water too long.

2.3 Latin name

Plant name on the label should be in Latin. Actually, it is recommended that the whole label should be in Latin but this is rarely done nowadays.

There are two parts of the Latin name, (1) *name of genus* and (2) *species epithet*. In addition, the name is often supplied with (3) *citation*, in botanical tradition, this is *author name(s)*:

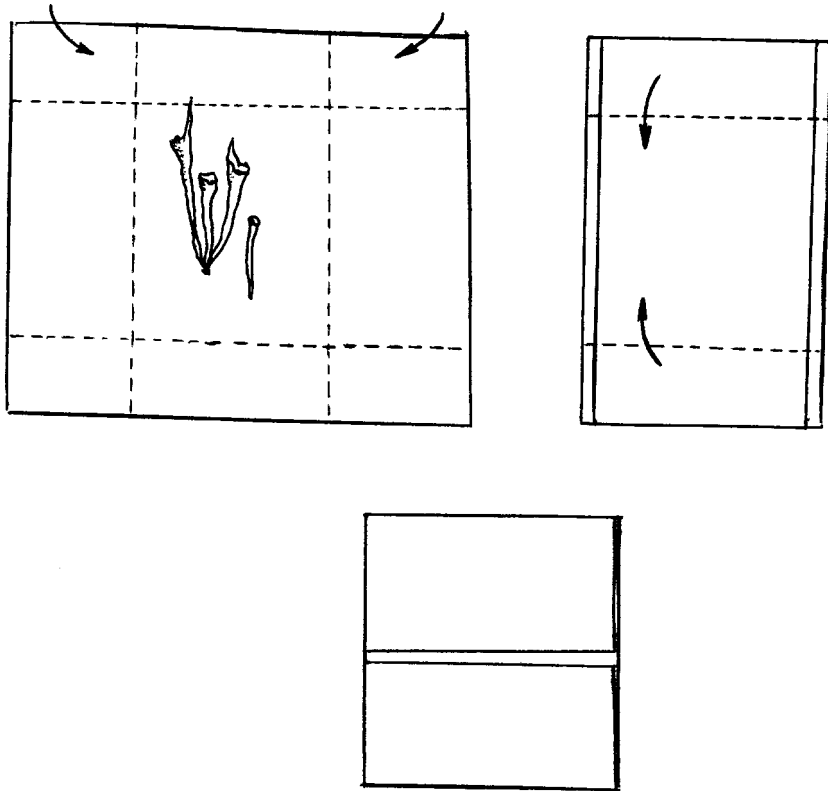

Figure 2.1: How to make the paper envelope.

Species name

Rorippa *sylvestris* (L.) Bess.

Genus name *Species epithet* *1st author* *2nd author*

In that case, Linnaeus first described the plant, and then Bessey transferred this species into another genus, hence parentheses.

Recommended literature

One of reason why this manual was prepared is that there are only few books published about herbarium collection. Some of them are available on-line.

Bridson D., Forman L. (eds.) 1992. *The Herbarium Handbook*. Revised edition. Royal Botanic Gardens, Kew, London.

Fosberg, F.R., Sachet M.L. 1965. *Manual for Tropical Herbaria*. No. 580.742 F6.

Saville, D. B. O. 1962. Collection and care of botanical specimens. *Canad. Dept. Agric., Publ. Res. Branch 1113*: 1–124.

Smith C.E. 1971. *Preparing herbarium specimens of vascular plants*. USDA Agricultural Information Bulletin.

De Vogel D.E. (ed.) 1987. *Manual of Herbarium Taxonomy: Theory and Practice*. Indonesia, UNESCO, Regional office for science and technology.

Good luck with your herbarium!

They started more than 400 years ago,
and hopefully have a long and bright future.